

# Farm King

## OPERATOR AND PARTS MANUAL

### 16" BACKSAVER AUGER

Models 1684, 16104, 16124

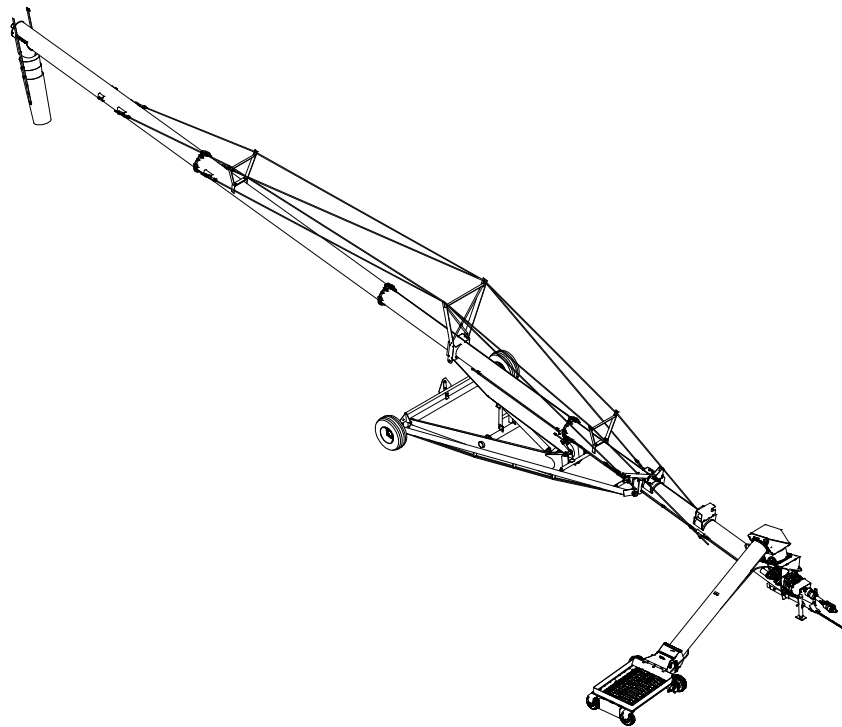



## TABLE OF CONTENTS

**Manufacturer's Statement:** For technical reasons, Farm King reserves the right to modify machinery design and specifications provided herein without any preliminary notice. Information provided herein is of descriptive nature. Performance quality may depend on soil fertility, applied agricultural techniques, weather conditions, and other factors.

WARRANTY REGISTRATION FORM.....	3
INTRODUCTION.....	5
SAFETY.....	11
OPERATION.....	23
MAINTENANCE.....	47
PARTS IDENTIFICATION.....	71
SPECIFICATIONS.....	143
WARRANTY.....	157

# Farm King



## WARRANTY REGISTRATION FORM

**This form must be filled out by the dealer and signed by both the dealer and the customer at the time of delivery.**

Customer Name:	
Customer Address:	
City:	Prov / State:
Postal / Zip Code:	Phone:

Dealer Name:	
Dealer Address:	
City:	Prov / State:
Postal / Zip Code:	Phone:

Auger Model:	Serial Number:	Delivery Date:
--------------	----------------	----------------

I have thoroughly instructed the buyer on the above described equipment which review included the Operator and Parts Manual content, equipment care, adjustments, safe operation and applicable warranty policy.

**Dealer Inspection Report**

- Bearings Turn Freely
- Winch Cable Tension Checked
- Bridging Cable Tension Checked
- Check Oil Level In Auger Drive Gear Box
- Fasteners Tight
- Lubricate Machine
- Check Tire Pressure
- Hopper Raises And Lowers Freely

**Safety**

- Safety Chain On Hitch (if equipped)
- All Decals Installed
- Guards And Shields Installed And Secure
- Review Operating And Safety Instructions
- Check For Hydraulic Leaks

Date:	Dealer Rep. Signature:
-------	------------------------

The above equipment and Operator And Parts Manual have been received by me and I have been thoroughly instructed as to care, adjustments, safe operation and applicable warranty policy.

Date:	Customer / Owner Signature:
-------	-----------------------------

**Remove this Warranty Registration Form from the Operator And Parts Manual. Make two copies of the form. Send original Warranty Registration Form to Farm King. Give one copy to the customer and the dealer will keep one copy.**

# Farm King



## INTRODUCTION

This Operator And Parts Manual was written to give the owner / operator instructions on the safe operation, maintenance and part identification of the Farm King equipment. READ AND UNDERSTAND THIS OPERATOR AND PARTS MANUAL BEFORE OPERATING YOUR FARM KING EQUIPMENT. If you have any questions, see your Farm King dealer. This manual may illustrate options and accessories not installed on your Farm King equipment.

OWNER'S INFORMATION.....	7
Serial Number Location.....	7
Manual Storage.....	7
EQUIPMENT IDENTIFICATION.....	8
1684 BS Auger.....	8
16104 BS Auger.....	9
16124 BS Auger.....	9

# Farm King



## OWNER'S INFORMATION

Thank you for your decision to purchase a Farm King Backsaver Auger. To ensure maximum performance of your equipment, it is mandatory that you thoroughly study the Operator And Parts Manual and follow the recommendations. Proper operation and maintenance are essential to maximize equipment life and prevent personal injury.

Operate and maintain this equipment in a safe manner and in accordance with all applicable local, state, and federal codes, regulations and / or laws. Follow all on-product labeling and instructions.

Make sure that all personnel have read this Operator And Parts Manual and thoroughly understand safe and correct operating, installation and maintenance procedures.

Farm King is continually working to improve its products. Farm King reserves the right to make any improvements or changes as deemed practical and possible without incurring any responsibility or obligation to make any changes or additions to equipment sold previously.

Although great care has been taken to ensure the accuracy of this publication, Farm King makes no warranty or guarantee of any kind, written or expressed, implied or otherwise with regard to the information contained within this manual. Farm King assumes no responsibility for any errors that may appear in this manual and shall not be liable under any circumstances for incidental, consequential or punitive damages in connection with, or arising from the use of this manual.

Keep this manual available for frequent reference. All new operators or owners must review the manual before using the equipment and annually thereafter. Contact your Farm King Dealer if you need assistance, information, or additional copies of the manual.

Visit our website at [www.farm-king.com](http://www.farm-king.com) for a complete list of dealers in your area.

The directions left, right, front and rear, as mentioned throughout this manual, are as viewed by the operator sitting in the tractor seat while towing the implement.

## Serial Number Location

Please enter the model and serial number in the space provided for easy reference.

**Figure 1**

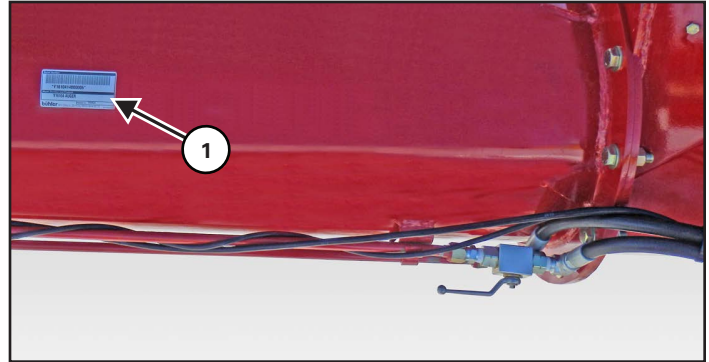

**Model Number:**

**Serial Number:**

The serial number plate (Item 1) is located on the front right side of tube #1, which is connected to the intake tube [Figure 1].

Always use your serial number when requesting information or when ordering parts.

## Manual Storage

**Figure 2**

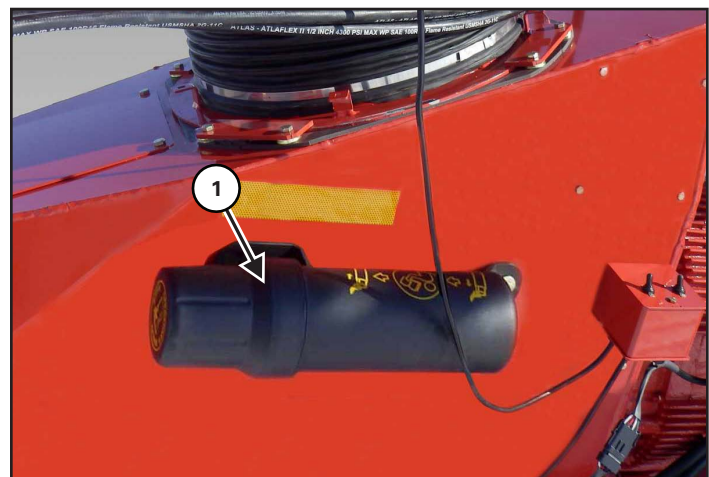

The operator and parts manual and other documents can be stored in the canister (Item 1) located on the RH side of the input box [Figure 2].

## EQUIPMENT IDENTIFICATION

### 1684 BS Auger

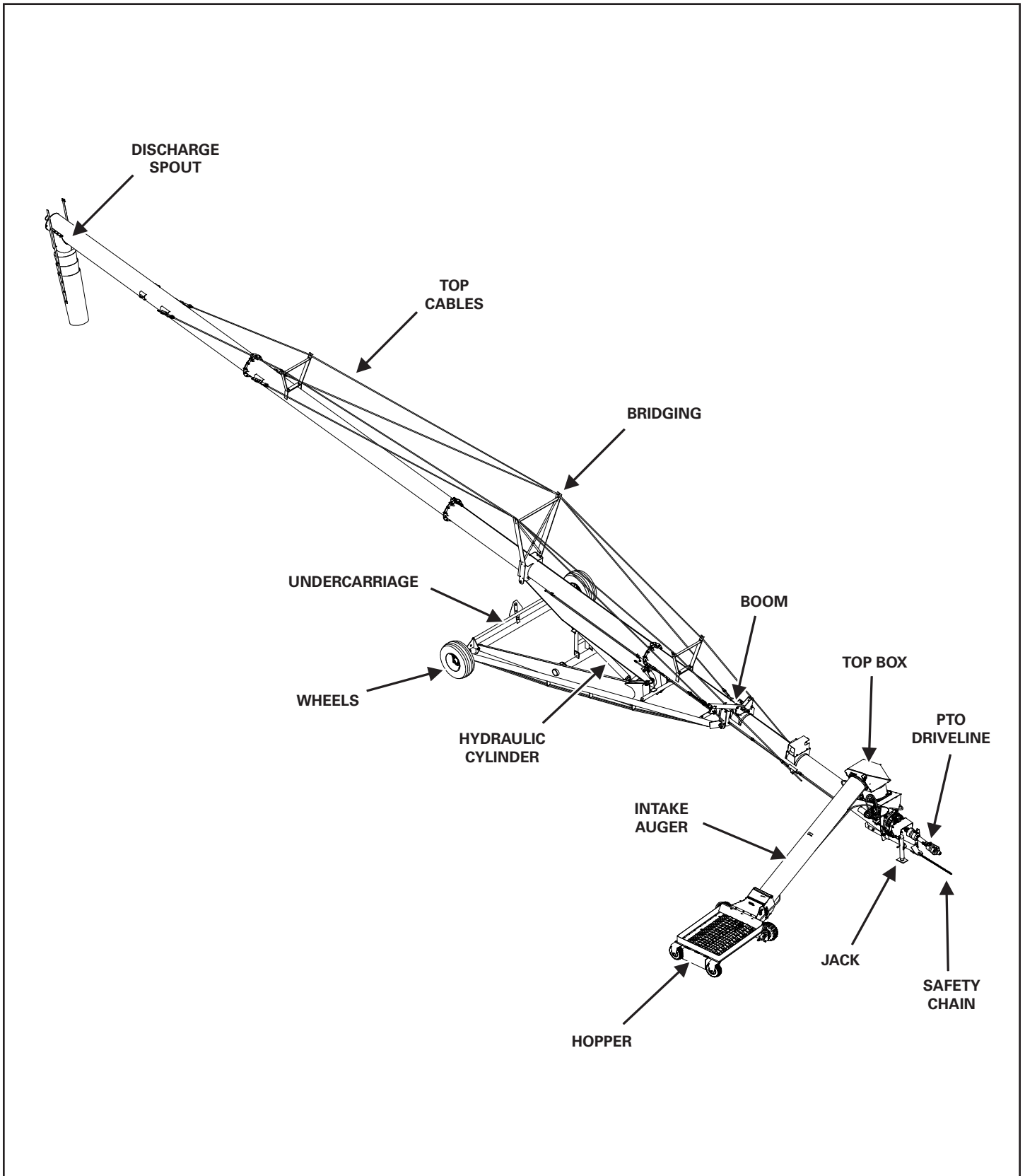

**16104 BS Auger**

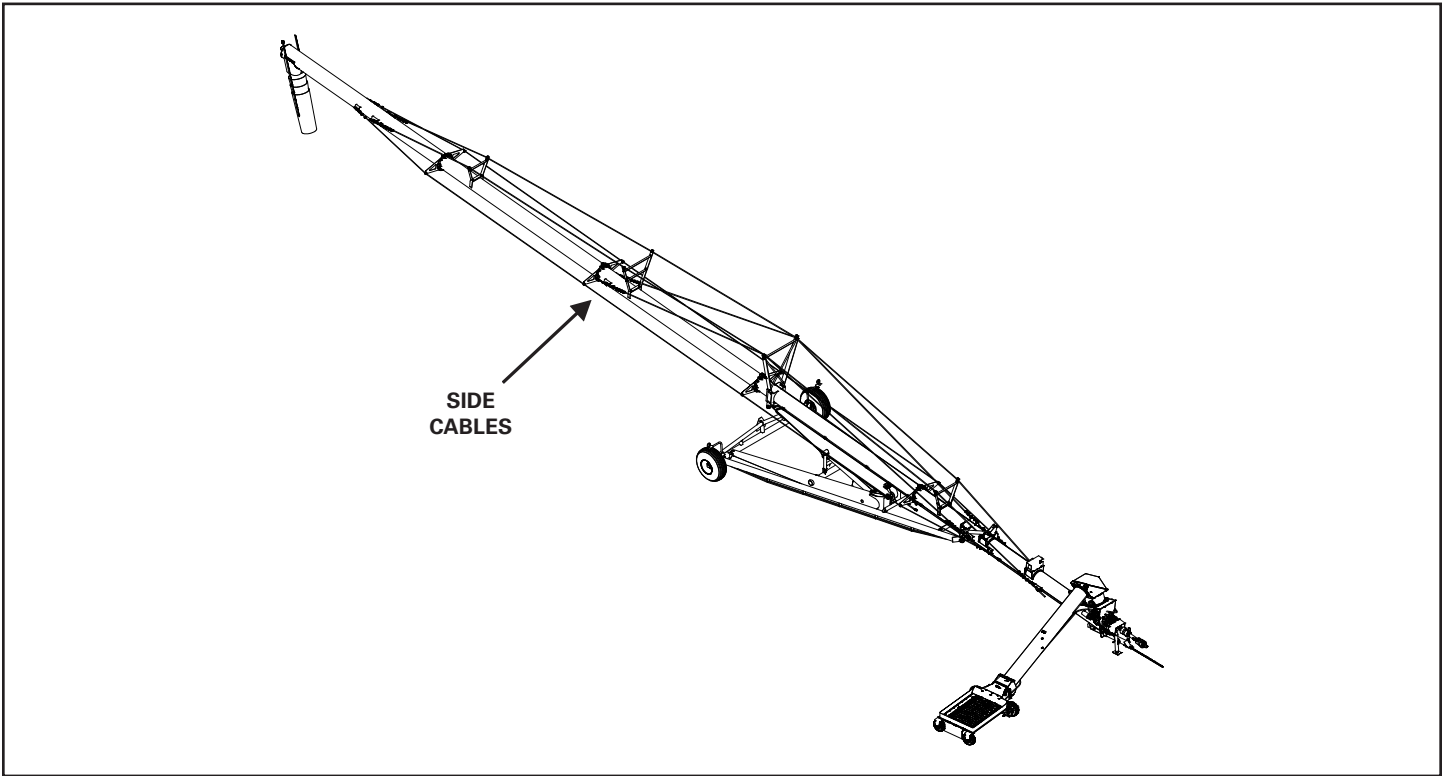

**16124 BS Auger**

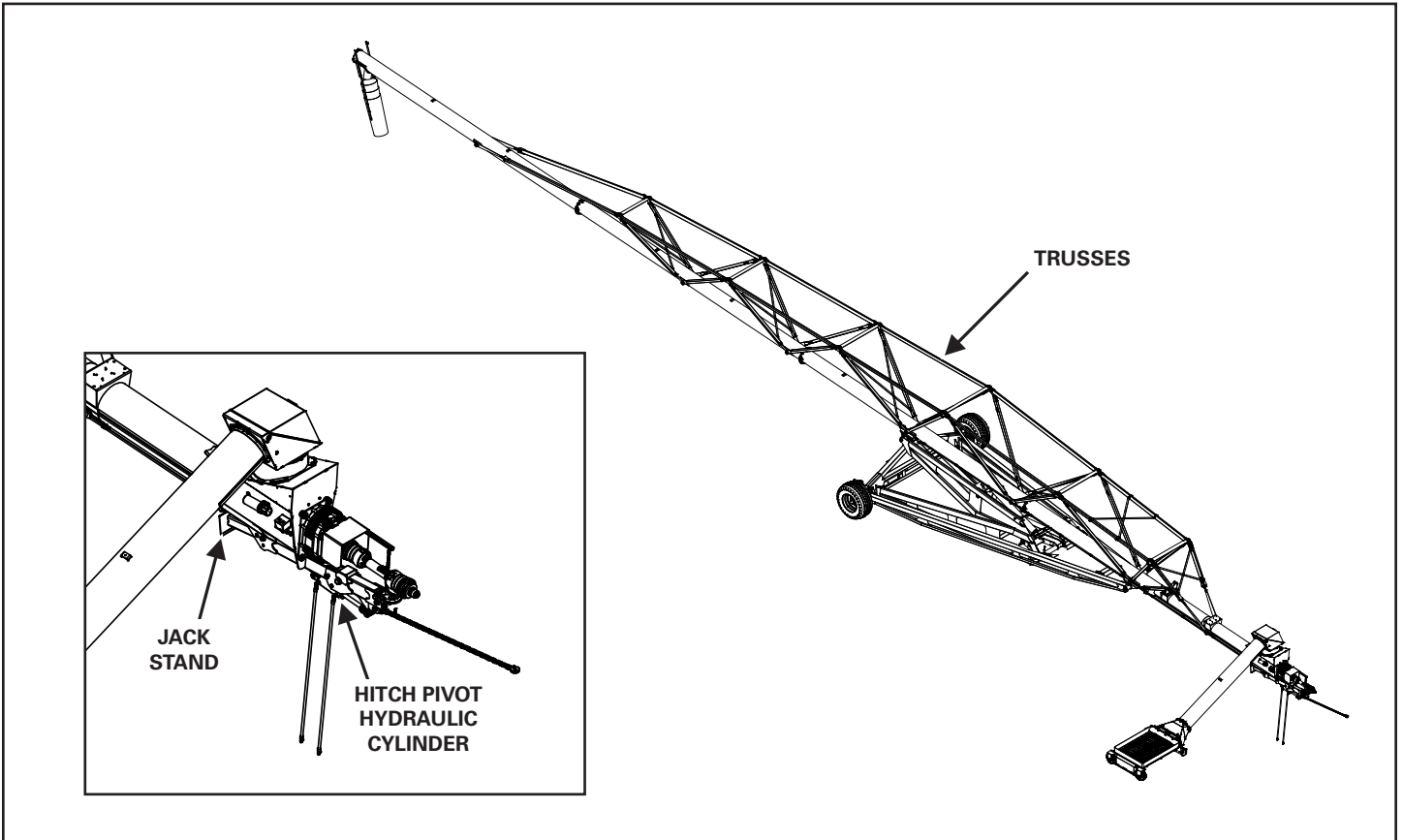

# Farm King



# SAFETY

- SAFETY INSTRUCTIONS..... 13
  - Safe Operation is The Operator’s Responsibility..... 13
  - Safe Operation Needs A Qualified Operator..... 13
  - Use Safety Rules..... 14
  - Safety Rules For Power Take-Off (PTO) Driven Equipment..... 14
  - Machine Requirements And Capabilities..... 15
  - Transport Safety..... 15
- FIRE PREVENTION..... 16
  - Maintenance..... 16
  - Operation..... 16
  - Fire Extinguishers..... 16
  - Electrical..... 16
  - Hydraulic System..... 16
  - Fueling..... 16
  - Welding And Grinding..... 16
- OPERATING SAFETY ZONE..... 17
  - Safety Zone Identification..... 17
- EQUIPMENT & SAFETY SIGNS..... 18
- SAFETY SIGN-OFF FORM..... 21

# Farm King



## SAFETY INSTRUCTIONS

### Safe Operation is The Operator's Responsibility



#### Safety Alert Symbol

This symbol with a warning statement means: "Warning, be alert! Your safety is involved!" Carefully read the message that follows.



## CAUTION

The signal word CAUTION on the machine and in the manuals indicates a potentially hazardous situation which, if not avoided, may result in minor or moderate injury. It may also be used to alert against unsafe practices.



## DANGER

The signal word DANGER on the machine and in the manuals indicates a hazardous situation which, if not avoided, will result in death or serious injury.



## WARNING

The signal word WARNING on the machine and in the manuals indicates a potentially hazardous situation which, if not avoided, could result in death or serious injury.



## IMPORTANT

This notice identifies procedures which must be followed to avoid damage to the machine.

### Safe Operation Needs A Qualified Operator



## WARNING

**Operators must have instructions before operating the machine. Untrained operators can cause injury or death.**

For an operator to be qualified, he or she must not use drugs or alcohol which impair alertness or coordination while working. An operator who is taking prescription drugs must get medical advice to determine if he or she can safely operate a machine and the equipment.

Understand the written instructions, rules and regulations:

- The written instructions from Farm King include the Warranty Registration, Dealer Inspection Report, Operator And Parts Manual and machine signs (decals).
- Check the rules and regulations at your location. The rules may include an employer's work safety requirements. Regulations may apply to local driving requirements or use of a Slow Moving Vehicle (SMV) emblem. Regulations may identify a hazard such as a utility line.

Have Training with Actual Operation:

- Operator training must consist of a demonstration and verbal instruction. This training is given by the machine owner prior to operation.
- The new operator must start in an area without bystanders and use all the controls until he or she can operate the machine safely under all conditions of the work area.

Know the Work Conditions:

- Clear working area of all bystanders, especially small children and all obstacles that might be hooked or snagged, causing injury or damage.
- Know the location of any overhead or underground power lines. Call local utilities and have all underground power lines marked prior to operation.
- Wear tight fitting clothing. Always wear safety glasses when doing maintenance or service.

## Use Safety Rules

- Read and follow instructions in this manual and the tractor's Operators Manual before operating.
- Under no circumstances should young children be allowed to work with this equipment.
- This equipment is dangerous to children and persons unfamiliar with its operation.
- If the elderly are assisting with work, their physical limitations need to be recognized and accommodated.
- Stay clear of overhead power lines when raising or lowering the auger. Electrocutation can occur without direct contact.
- Check for overhead and / or underground lines before operating equipment (if applicable).
- In addition to the design and configuration of equipment, hazard control and accident prevention are dependent upon the awareness, concern, prudence and proper training of personnel involved in the operation, transport, maintenance and storage of equipment.
- Check that the equipment is securely fastened to the tractor / towing vehicle.
- Make sure all the machine controls are in the NEUTRAL position before starting the machine.
- Operate the equipment only from the operator's position.
- Operate the equipment according to the Operator And Parts Manual.
- When learning to operate the equipment, do it at a slow rate in an area clear of bystanders, especially small children.
- DO NOT permit personnel to be in the work area when operating the equipment.
- The equipment must be used ONLY on approved tractors / transport vehicles.
- DO NOT modify the equipment in any way.
- Unauthorized modification may impair the function and / or safety and could affect the life of the equipment.
- DO NOT make any adjustments or repairs on the equipment while the machine is running.
- Keep shields and guards in place. Replace if damaged.

## Safety Rules For Power Take-Off (PTO) Driven Equipment

- Keep PTO shields and all guards in place. Replace damaged or missing shields and guards before operating.
- Follow warnings and instructions on machine signs (decals). Replace damaged or missing decals.
- Do not wear loose or bulky clothing around the PTO or other moving parts.
- Keep bystanders away from PTO driven equipment, and never allow children near machines.
- Read and understand the manuals for the PTO driven equipment and be aware of safe operating procedures and hazards that may not be readily apparent.
- Always walk around equipment to avoid coming near a turning PTO driveline. Stepping over, leaning across or crawling under a turning PTO driveline can cause entanglement.
- Position the machine and equipment hitch correctly to prevent driveline stress and separation.
- Use caution when turning. Turning too sharp can cause driveline damage.
- Use caution when raising PTO driven attachment.

## Machine Requirements And Capabilities

- Stop the machine and engage the parking brake. Install blocks in front of and behind the rear tires of the machine. Install blocks underneath and support the equipment securely before working under raised equipment.
- Keep bystanders clear of moving parts and the work area. Keep children away.
- Use increased caution on slopes and near banks and ditches to prevent overturn.
- Make certain that the Slow Moving Vehicle (SMV) emblem is installed so that it is visible and legible. When transporting the equipment, use the flashing warning lights (if equipped) and follow all local regulations.
- Operate this equipment with a machine equipped with an approved Roll-Over Protective Structure (ROPS). Always wear seat belt when the ROPS is up. Serious injury or death could result from falling off the machine.
- Before leaving the operator's position:
  1. Always park on a flat level surface.
  2. Place all controls in neutral.
  3. Engage the parking brake.
  4. Stop engine.
  5. Wait for all moving parts to stop.
- Carry passengers only in designated seating areas. Never allow riders on the machine or equipment. Falling off can result in serious injury or death.
- Start the equipment only when properly seated in the operator's seat. Starting a machine in gear can result in serious injury or death.
- Operate the machine and equipment from the operator's position only.
- The parking brake must be engaged before leaving the operator's seat. Roll away can occur because the transmission may not prevent machine movement.

## Transport Safety

- Do not exceed 20 mph (32 kph). Reduce speed on rough roads and surfaces.
- Comply with state and local laws governing highway safety and movement of machinery on public roads.
- The use of flashing amber lights is acceptable in most localities. However, some localities prohibit their use.
- Local laws should be checked for all highway lighting and marking requirements.
- Always install transport locks, pins or brackets before transporting.
- Always yield to oncoming traffic in all situations and move to the side of the road so any following traffic may pass.
- Always enter curves or drive up or down hills at a low speed and at a gradual steering angle.
- Never allow riders on either tractor or equipment.
- Keep tractor / towing vehicle in a lower gear at all times when traveling down steep grades.
- Maintain proper brake settings at all times (if equipped).
- Stay away from overhead power lines when auger is raised. Electrocuting can occur without direct contact.

## FIRE PREVENTION



### Maintenance

- The machine and some equipment have components that are at high temperatures under normal operating conditions. The primary source of high temperatures is the engine and exhaust system. The electrical system, if damaged or incorrectly maintained, can be a source of arcs or sparks.
- Flammable debris (leaves, straw, etc.) must be removed regularly. If flammable debris is allowed to accumulate, it can cause a fire hazard. Clean often to avoid this accumulation. Flammable debris in the engine compartment is a potential fire hazard.
- All fuels, most lubricants and some coolant mixtures are flammable. Flammable fluids that are leaking or spilled onto hot surfaces or onto electrical components can cause a fire.

### Operation

- The Farm King machine must be in good operating condition before use.
- Check all of the items listed on the service schedule under the 8 hour column before operation. (See Maintenance section)
- Do not use the machine where exhaust, arcs, sparks or hot components can contact flammable material, explosive dust or gases.

### Fire Extinguishers



- Know where fire extinguishers and first aid kits are located and how to use them. Inspect the fire extinguisher and service the fire extinguisher regularly. Obey the recommendations on the instructions plate.

### Electrical



- Check all electrical wiring and connections for damage. Keep the battery terminals clean and tight. Repair or replace any damaged part or wires that are loose or frayed. Battery gas can explode and cause serious injury. Do not jump start or charge a frozen or damaged battery. Keep any open flames or sparks away from batteries. Do not smoke in battery charging area.

### Hydraulic System

- Check hydraulic tubes, hoses and fittings for damage and leakage. Never use open flame or bare skin to check for leaks. Hydraulic tubes and hoses must be properly routed and have adequate support and secure clamps. Tighten or replace any parts that show leakage. Always clean fluid spills. Do not use gasoline or diesel fuel for cleaning parts. Use commercial nonflammable solvents.

### Fueling



- Stop the engine and let it cool before adding fuel. No smoking! Do not refuel a machine near open flames or sparks. Fill the fuel tank outdoors.

### Welding And Grinding

- Always clean the machine and equipment, disconnect the battery, and disconnect the wiring from the machine controls before welding. Cover rubber hoses, battery and all other flammable parts. Keep a fire extinguisher near the machine when welding.
- Have good ventilation when grinding or welding painted parts. Wear dust mask when grinding painted parts. Toxic dust or gas can be produced.
- Dust generated from repairing nonmetallic parts such as hoods, fenders or covers can be flammable or explosive. Repair such components in a well ventilated area away from open flames or sparks.

**OPERATING SAFETY ZONE**

**Safety Zone Identification**



**AVOID INJURY OR DEATH**

- Do not allow small children, bystanders or unauthorized persons in the work area during operation.
- Never stand or work under the auger and undercarriage when in the raised position or during operation.
- Always keep PTO shields and all guards in place during operation.
- Keep away from moving parts.
- Keep everyone clear when operating the hopper mover.



**ELECTROCUTION HAZARD**

Keep away from power lines, electrocution can occur without direct contact.



- Owners and operators should allow only authorized personnel and grain transport vehicles near the auger or inside the work area.
- Allow adequate space for grain transport vehicles to operate safely.
- Make certain everyone is clear of the equipment before applying power or moving the machine.
- While in operation, always support the discharge end or provide adequate anchorage of the intake end to prevent sudden tipping.

**Figure 3**

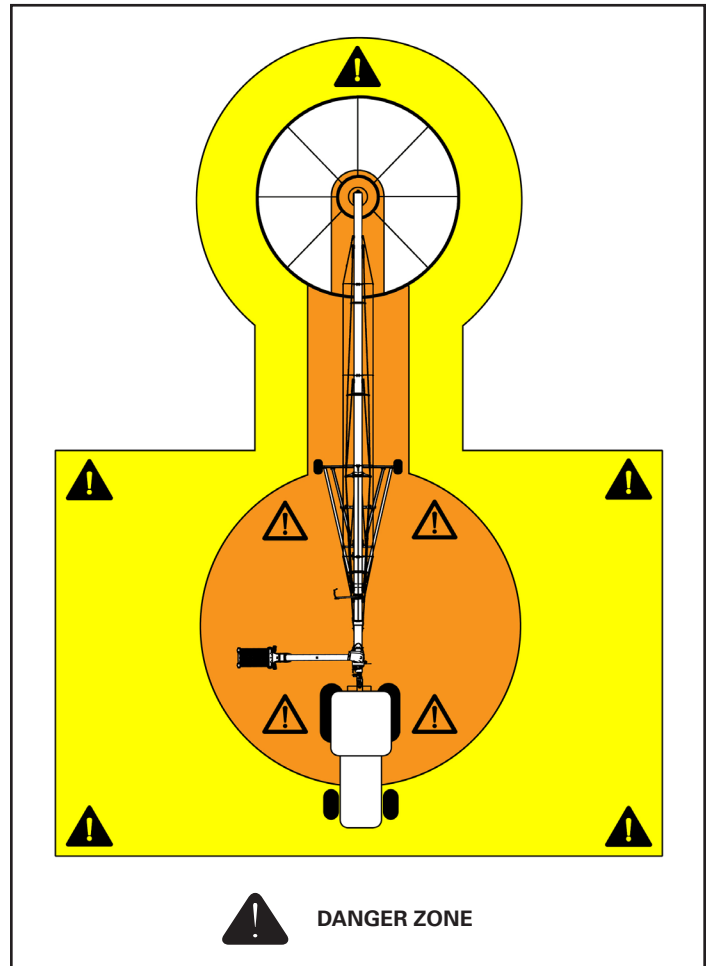

## EQUIPMENT & SAFETY SIGNS

Follow the instructions on all the signs (decals) that are on the equipment. Replace any damaged signs (decals) and be sure they are in the correct locations. Equipment signs are available from your Farm King equipment dealer.

Electrocution Hazard, PN 909745



Upending Hazard, PN 960569



Driveline Hazard, PN 904585



PTO Warning, PN 108431



PTO Important, PN 960371



Check Oil, PN 967388



Align Yoke, PN 960372

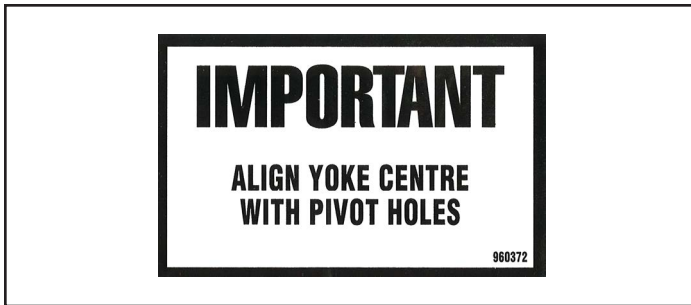

Intake Caution, PN 917765



Caution, PN 963206



List Caution, PN 961017

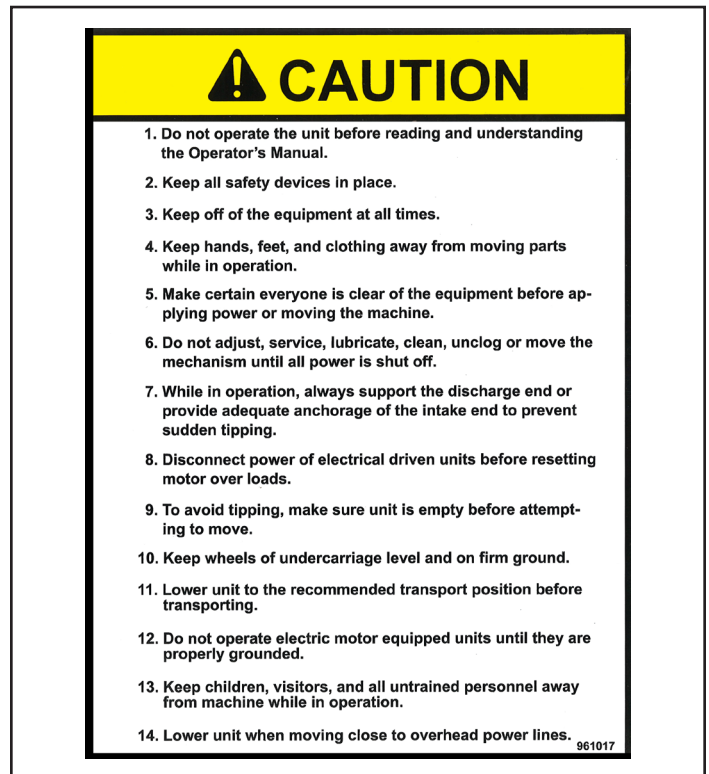

Danger, PN 961016



Run Auger, PN 961015



Pinch Points, PN 932472



MODEL BS1684, PN 912849

**1684**

MODEL BS16104, PN 910579

**16104**

MODEL BS16124, PN 935030

**16124**

Farm King BS1684, BS16104, BS16124  
PN 930722

**Farm King**

Amber Reflector BS1684 & BS16104, PN 52773-000

Amber Reflector BS16124, PN 967055

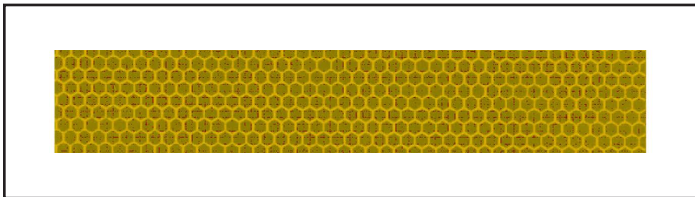

Red Reflector BS1684 & BS16104, PN 52774-000

Red Reflector BS16124, 967053

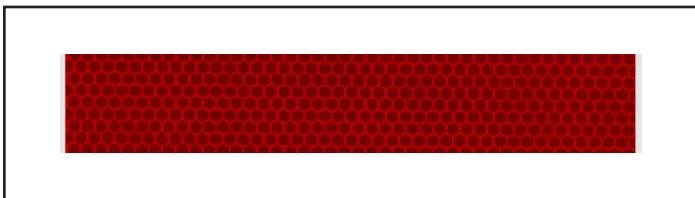

Grease Location, PN 966699

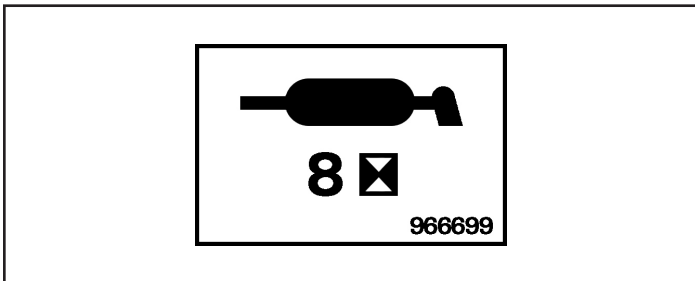

Add Oil, PN 939480

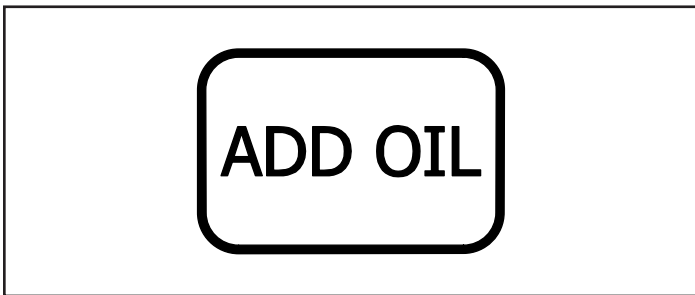



# Farm King



## OPERATION

GENERAL INFORMATION.....	25
Pre - Operation Checklist.....	25
Break - In Checklist.....	26
Tractor And Gas Engine Requirements.....	27
Drawbar Adjustment.....	27
ENTERING & LEAVING THE OPERATOR'S POSITION.....	28
Entering The Operator's Position.....	28
Leaving The Operator's Position.....	28
CONNECTING TO TRACTOR.....	28
Hitching 1684 / 16104 Model Auger.....	28
Hitching 16124 Model Auger.....	30
Connecting The PTO Driveline.....	32
PTO Driveline Length Check.....	33
PTO Driveline Bottoming Out Check.....	33
Reducing The PTO Driveline Length.....	34
PTO Driveline Engagement Check.....	35
Connecting Hydraulic Hoses.....	36
AUGER OPERATION.....	37
Adjusting Flow Control Valve.....	37
Auger Placement.....	38
Unloading Belly Dump Units.....	39
Unloading Rear And Side Dump Units.....	41
TRANSPORTATION.....	42
Requirements.....	42
Transporting Procedure.....	43

# Farm King



**GENERAL INFORMATION**

**Pre - Operation Checklist**

Before operating the auger for the first time and each time thereafter, check the following items:



**AVOID INJURY OR DEATH**

- Disengage the PTO, engage the machine’s parking brake, stop the engine and make sure all rotating components are completely stopped before connecting, disconnecting, adjusting or cleaning any PTO driven equipment.
- Always keep PTO shields and all guards in place when using PTO driven equipment.
- Disengage PTO for road travel.
- Keep hands, feet and clothing away.



**AVOID INJURY OR DEATH**

**Wear safety glasses to prevent eye injury when any of the following conditions exist:**

- When fluids are under pressure.
  - Flying debris or loose material is present.
  - Engine is running.
  - Tools are being used.
- 
1. Lubricate the equipment per the schedule outline in the Maintenance Section.
  2. Check the augers. Remove any material build-up or debris that has become entangled.

3. Make sure that all guards and shields are in place, secured and functioning as designed.



**HIGH PRESSURE FLUID HAZARD**

Leaking fluids under pressure can enter the skin and cause serious injury or death. Immediate medical attention is required. Wear goggles. Use cardboard to check for leaks.

4. Check condition of all hydraulic components for leaks. Repair as required.

**Note:** Do not operate with hydraulic leaks.

5. Check and tighten all wheel bolts to proper torque.
6. Check tire pressure. Inflate per manufacturer’s specification.
7. Check gearbox oil level. Fill as required (see Maintenance section).
8. Check that the PTO driveline telescope easily and turn freely.
9. Make sure the PTO ends are securely attached to the auger and the tractor.
10. Check the drive belt tension and alignment. Tension or align as required (see Maintenance section).

### Break - In Checklist

**Note:** The break-in period is different from normal operating conditions.

The tube and flighting must get a polished surface through use. Once the new auger has polished it will run smooth at recommended speed.

**Note:** Never operate an empty auger for over one minute, as the flighting and housing will experience excessive wear.

During the break-in-period:

1. Run the tractor at slow idle until grain begins to flow from the discharge. For the first 500 bushels, operate at the slow speed and restrict the flow of grain at the intake.
2. Gradually increase the speed until operating at full PTO speed.

**Note:** Do not run empty during break-in period.



### AVOID INJURY OR DEATH

- Disengage the PTO, engage the machine’s parking brake, stop the engine and make sure all rotating components are completely stopped before connecting, disconnecting, adjusting or cleaning any PTO driven equipment.
- Always keep PTO shields and all guards in place when using PTO driven equipment.
- Disengage PTO for road travel.
- Keep hands, feet and clothing away.

Check the following mechanical items after 1 hour of operation and again after 10 hours of operation:

1. Re-torque wheel bolts to proper torque and check tire pressure.
2. Check for loose fasteners and hardware. Tighten as required.
3. Check the condition of all hydraulic lines, hoses, fittings and couplers for damage or leaks.
4. Tighten leaking fittings and repair or replace any damaged components.
5. Check the condition of all electrical lines, wires, and connections. Repair or replace any damaged systems or components.
6. Check that all guards and shields are in place, secured and functioning as designed.

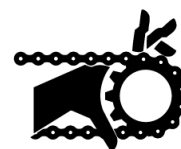

### ROTATING PART HAZARD

To prevent serious injury or death from rotating parts:

- Place all controls in neutral or off, stop engine or motor, remove ignition key or disable power source and wait for all moving parts to stop before servicing, adjusting, repairing or unplugging.
- Install and secure all guards / shields before operating.
- Do not operate with rotating parts exposed.

Tractor And Gas Engine Requirements



- Do NOT exceed 1000 RPM PTO
- Keep PTO shields and all guards in place.
- Keep away from moving parts.
- Keep bystanders away.

The tractor / tow vehicle must be rated for the listed weight to transport the specified auger model.

Hitch weight and total weight of the auger models:

Auger Model	Hitch Weight	Total Weight
1684	2,460 lb (1,115 kg)	11,000 lb (4,994 kg)
16104	2,460 lb (1,115 kg)	16,500 lb (6,120 kg)
16124	3,810 lb (1,728 kg)	23,010 lb (10,437 kg)

Minimum HP (1000 RPM PTO):

Auger Model	Minimum Tractor HP
1684	150 HP
16104	175 HP
16124	250 HP

The tractor must be equipped with:

- 20-spline 1-3/4" PTO shaft
- Three auxiliary hydraulic functions
- Category IV rated drawbar
- 7-Pin electrical connection

Drawbar Adjustment

Figure 4

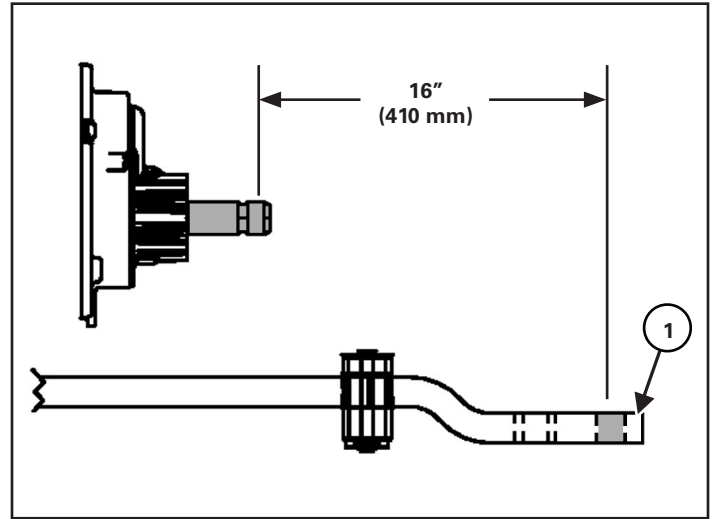

Adjust the tractor’s drawbar in / out, until the center of the hitch pin hole (Item 1) is 16 inches (410 mm) from the end of the tractor’s PTO shaft. See your tractor’s owner’s manual for correct adjustment procedures [Figure 4].

**NOTE:** A tractor hitch of less than 16" minimum will result in PTO bottoming out, when operating auger at maximum height.

Figure 5

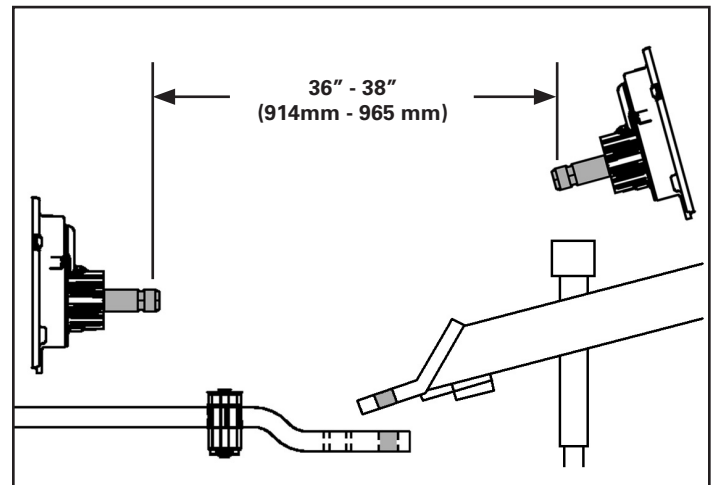

The distance between the tractor and the auger PTO shaft should be between 36 - 38 in. (914 - 965 mm) with the tractor and auger on level ground and the auger in full down position. This distance is obtained by either adjusting the tractor hitch, the auger hitch or both [Figure 5].

## ENTERING & LEAVING THE OPERATOR'S POSITION

### Entering The Operator's Position

Enter the operator's position, start the engine, and release the parking brake.



## IMPORTANT

Follow the instructions in your tractor's operation manual for the correct procedure.

### Leaving The Operator's Position

Always perform the following steps when leaving the operator's position:



## WARNING

### AVOID INJURY OR DEATH

Before you leave the operator's position:

- Always park on a flat level surface.
- Place all controls in NEUTRAL.
- Engage the park brake.
- Stop the engine and remove the key.
- Wait for all moving parts to stop.

## CONNECTING TO TRACTOR

Attach the auger to the tractor whenever the equipment is moved around the yard or into working position.

Tow the equipment by truck when traveling long distances (see "Transportation" on page 42).

### Hitching 1684 / 16104 Model Auger

Make sure that bystanders, especially small children, are clear of the working area.

Be sure that there is sufficient room and clearance to back up to the machine.



## WARNING



Before moving the tractor, look in all directions and make sure no bystanders, especially small children are in the work area. Do not allow anyone between the tractor and the equipment when backing up to the equipment for connecting.

Move the tractor backwards, aligning the drawbar with the Backsaver Auger hitch.

**NOTE:** The jack may need to be lowered or raised for proper alignment of the drawbar and hitch.

If the Backsaver Auger hitch needs to be adjusted, stop the tractor when drawbar is just in front of the Backsaver Auger hitch.

Leave the operator's position.

Figure 6

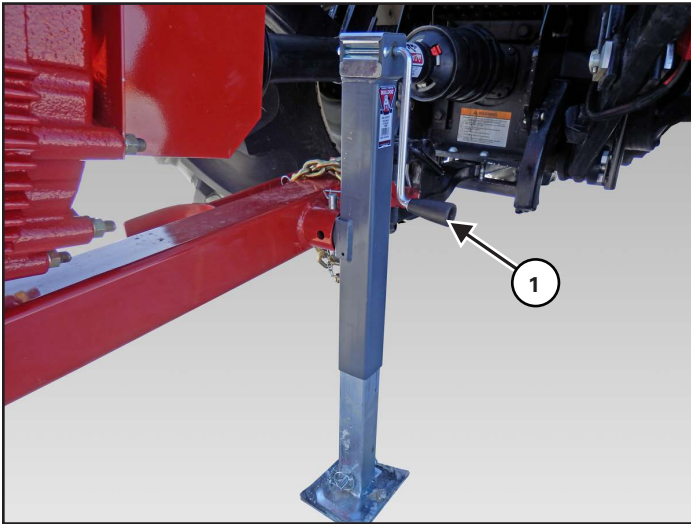

Turn the handle (Item 1) clockwise to raise the hitch or counterclockwise to lower the hitch [Figure 6].

Lower or raise the Backsaver Auger hitch until aligned with the tractor's drawbar.

Move to the operator's seat, start the engine and release the parking brake.

Move the tractor backwards, aligning the drawbar hitch pin hole with the Backsaver Auger hitch pin hole(s).

Stop the tractor and leave operator's position.



**AVOID INJURY OR DEATH**

**Keep fingers and hands out of pinch points when connecting and disconnecting equipment.**

**NOTE:** Always use a hitch pin of adequate size and strength and a retaining pin with a locking device.

Figure 7

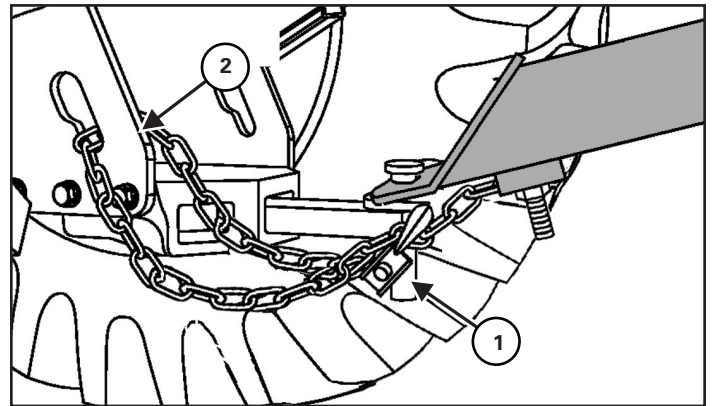

Install the hitch pin (Item 1) and retaining pin to securely fasten the Backsaver Auger hitch to the tractor drawbar [Figure 7].

Attach the safety chain (Item 2) around the drawbar [Figure 7].

Figure 8

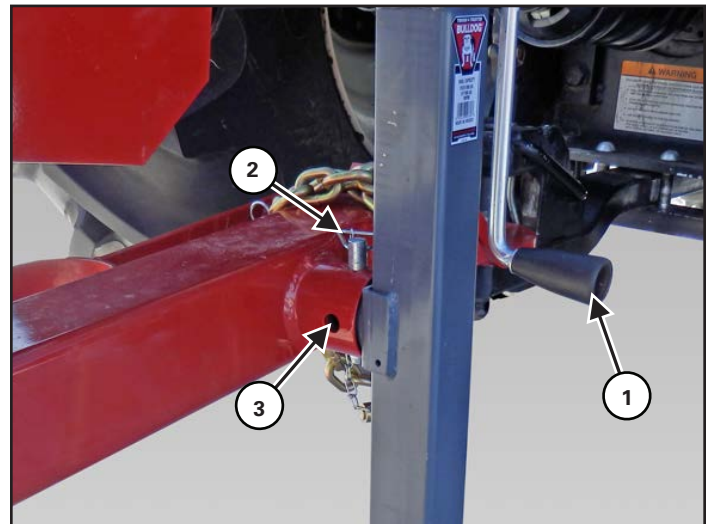

Turn the handle (Item 1) counterclockwise to loosen the jack [Figure 8].

Remove the pin (Item 2) and rotate the jack to transport position and install the pin into transport position (Item 3) [Figure 8].

### Hitching 16124 Model Auger

Make sure that bystanders, especially small children, are clear of the working area.

Be sure that there is sufficient room and clearance to back up to the machine.



**Before moving the tractor, look in all directions and make sure no bystanders, especially small children are in the work area. Do not allow anyone between the tractor and the equipment when backing up to the equipment for connecting.**

Move the tractor backwards, aligning the drawbar with the auger hitch.

If the auger hitch needs to be adjusted, stop the tractor when drawbar is just in front of the auger hitch.

Stop the tractor and leave operator's position.

Connect the hydraulic hoses from the hitch cylinder to the tractor remote couplers.

Enter the operator's position.

Operate the proper tractor hydraulic control to raise the auger hitch high enough to allow tractor drawbar to be aligned with auger hitch. Lower auger hitch onto drawbar hitch.

Install the hitch pin and retaining pin to securely fasten the Backsaver Auger hitch to the tractor drawbar.

**NOTE:** Always use a hitch pin of adequate size and strength and a retaining pin with a locking device.

Attach the safety chain around the drawbar.

**Figure 9**

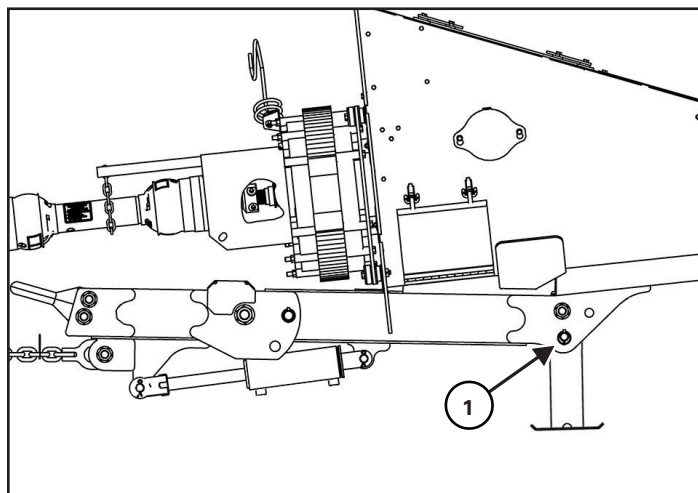

Act on hydraulic controls to raise the auger hitch high enough to move the auger stand. Remove auger stand locking pin (Item 1) [Figure 9].

**Figure 10**

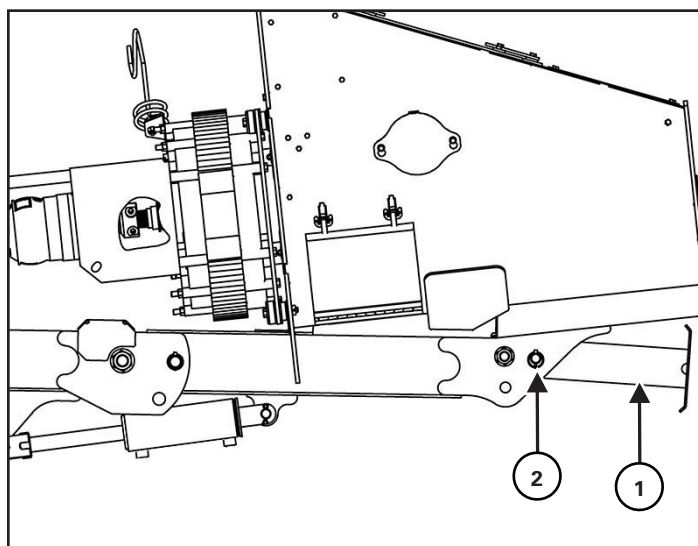

Rotate auger stand (Item 1) upward into storage position and install auger stand locking pin (Item 2) [Figure 10].

Figure 11

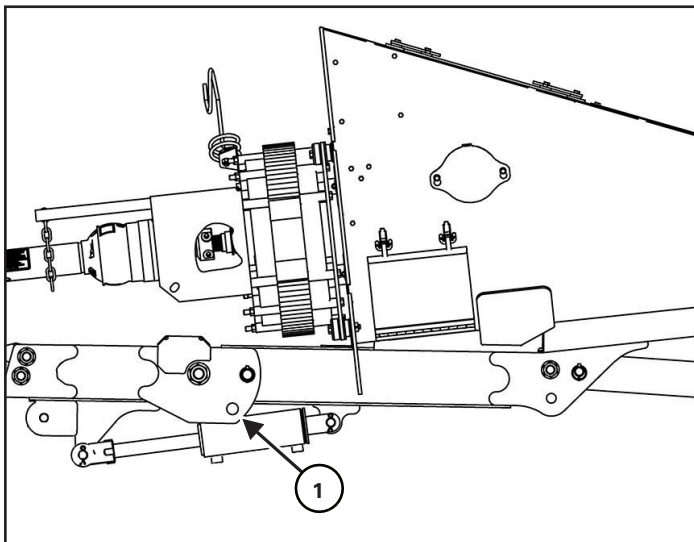

Operate the proper tractor hydraulic control to adjust the auger hitch to align holes and install hitch locking pin (Item 1) in transport position [Figure 11].



## WARNING

**Do NOT operate equipment without locking pins in place.**

**NOTE:** Clean and grease tractor's PTO shaft and PTO driveline coupling each time driveline is connected.

### Connecting The PTO Driveline



#### **AVOID INJURY OR DEATH**

Warnings on the machine and in the manuals are for your safety. Failure to obey warnings can cause serious injury or death.

**NOTE:** Clean and grease tractor's PTO shaft and PTO driveline coupling each time driveline is connected.

Stop the engine and leave the operator's position.



**Improper hitch installation can cause PTO driveline damage. Do not modify the hitch or use an unapproved hitch. Make sure the PTO driveline is of adequate length and that u-joints are in the correct phase**

Remove the PTO driveline from the storage position (if applicable).

Figure 12

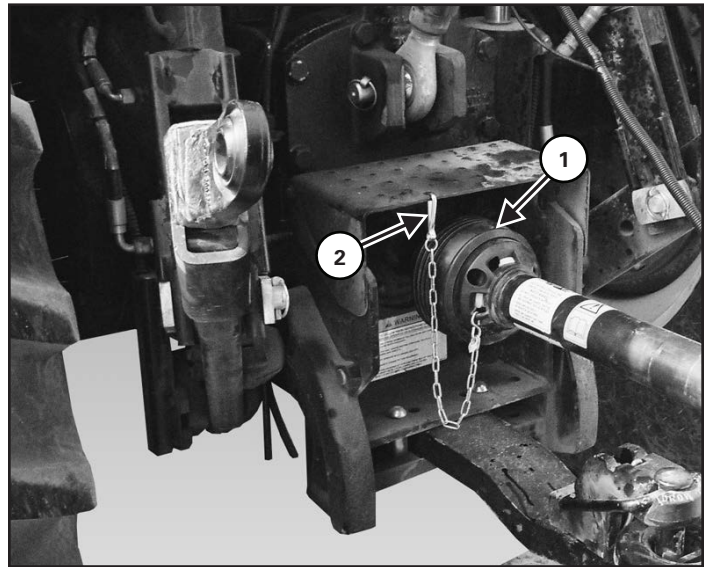

Retract the collar and slide the PTO driveline (Item 1) onto the tractor PTO shaft until it locks onto the shaft. Push and pull on the PTO driveline to verify it is securely attached to the PTO shaft. Install PTO driveline safety chain (Item 2) [Figure 12].

**NOTE:** The PTO driveline must have a means to retain it to the PTO shaft on the tractor.



#### **AVOID INJURY OR DEATH**

**Do NOT exceed 1000 RPM PTO.**

**Keep PTO shields and all guards in place.**

**Keep away from moving parts.**

**Keep bystanders away.**

### PTO Driveline Length Check

Due to variations in distances between tractor PTO shafts and implement input shafts, drivelines may need to be shortened or a longer shaft may be required.

When fitting the implement to the tractor, the PTO driveline, with telescoping sections, must be inspected. When the sections are at the most compressed operating position, the sections must not "bottom out".

At its shortest length, there must be at least 2 in. (50.8 mm) of clearance between each section end and opposite section end at the most compressed operating position.

When the sections are at the most extended position, there must be sufficient engagement between the sections.

At its farthest operating extension, a minimum section engagement of 33% of shaft length must be maintained.



## WARNING

### AVOID INJURY OR DEATH

- Do NOT exceed the rated implement PTO speed.
- Stay clear of rotating driveline.
- Keep bystanders away.
- Keep hands, feet, clothing and long hair away.
- Keep PTO shields and all guards in place.
- Disengage PTO, move the tractor controls to the Neutral position, stop the engine and make sure all rotating components are stopped before leaving the operator's position.
- Do NOT service the tractor or implement with the PTO engaged.
- Do NOT service the implement in a raised position unless properly blocked and with all rotating components stopped.
- Disengage PTO for road travel.

### PTO Driveline Bottoming Out Check

Stop the engine and leave the operator's position (See "Leaving The Operator's Position" in Operation section).

Make sure the PTO driveline and all rotating components have come to a complete stop before leaving the operator's position (if applicable).

**Figure 13**

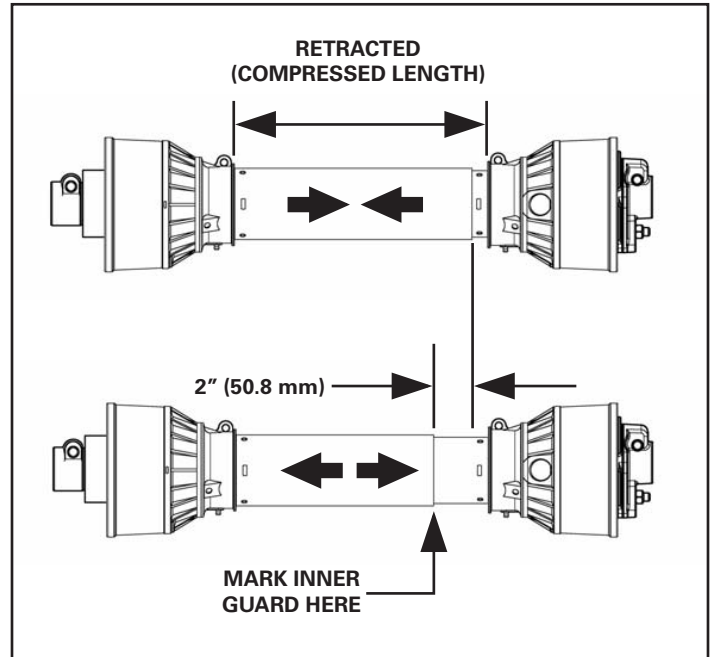

1. Disconnect the PTO driveline from the tractor and slide the PTO driveline together until fully retracted (compressed).
2. Measure the retracted (compressed) length of PTO driveline [Figure 13].
3. Extend the PTO driveline 2 in. (50.8 mm) from the retracted length and place a mark on the inner guard at the end of the outer guard [Figure 13].
4. Reattach the PTO driveline to the tractor PTO shaft.
5. Enter the operator's position. Start the engine.
6. With the rear PTO DISENGAGED, raise and lower the implement and watch the PTO driveline extend and retract.
7. If the outer PTO driveline guard slides in (retracts) over the mark at any point of travel, the PTO driveline needs to be shortened.

## Reducing The PTO Driveline Length

Stop the engine and leave the operator's position (See "Leaving The Operator's Position" in the Operation section). Make sure the PTO driveline and all rotating components have come to a complete stop before leaving the operator's position.



### AVOID INJURY OR DEATH

- Do NOT exceed the rated implement PTO speed.
- Stay clear of rotating driveline.
- Keep bystanders away.
- Keep hands, feet, clothing and long hair away.
- Keep PTO shields and all guards in place.
- Disengage PTO, move the tractor controls to the Neutral position, stop the engine and make sure all rotating components are stopped before leaving the operator's position.
- Do NOT service the tractor or implement with the PTO engaged.
- Do NOT service the implement in a raised position unless properly blocked and with all rotating components stopped.
- Disengage PTO for road travel.

Remove the PTO driveline from the tractor and place in storage position (if equipped).

Enter the operator's position (See "Entering The Operator's Position" in the Operation section). Start the engine.

Raise or lower the three-point implement to get the shortest distance between the tractor PTO shaft and three-point implement gearbox PTO shaft. Stop the engine and leave the operator's position.

Pull the PTO driveline apart and reinstall each individual section; one half to the tractor PTO shaft and one half to the implement gearbox PTO shaft.

**Figure 14**

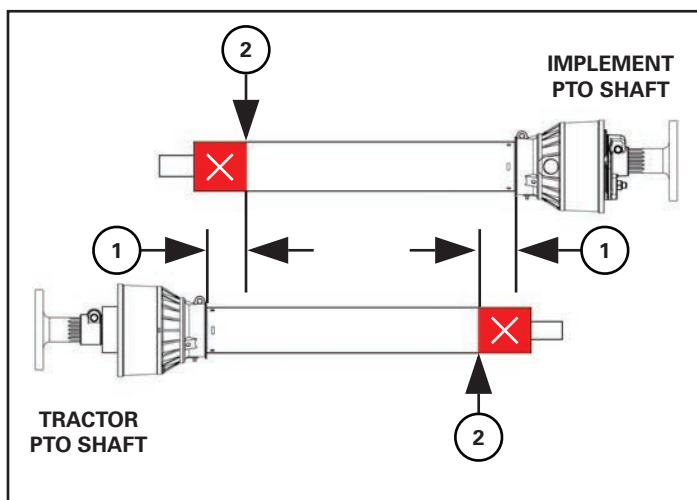

1. Hold PTO driveline sections parallel to one another and measure back 2 in. (50.8 mm) (Item 1) from the yoke of each section and place mark on opposite section. Cut the plastic shield at this length (Item 2) [Figure 14].

**Figure 15**

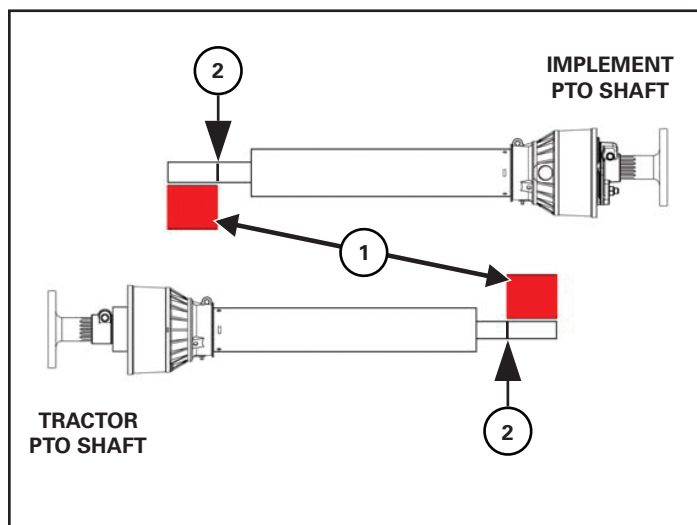

2. Using the plastic guard lengths that were cut off in, align the cut off lengths (Item 1) with the end of the inner & outer shafts. Place a mark (Item 2) on the inner & outer shafts and cut the inner & outer shafts off at this length [Figure 15].
3. Round off all sharp edges and debur.
4. Thoroughly grease and install the PTO driveline halves together.
5. Recheck for proper operation.

### PTO Driveline Engagement Check

Stop the engine and leave the operator’s position (See “Leaving The Operator’s Position” in the Operation section).

Make sure the PTO driveline and all rotating components have come to a complete stop before exiting the tractor.



### AVOID INJURY OR DEATH

- Do NOT exceed the rated implement PTO speed.
- Stay clear of rotating driveline.
- Keep bystanders away.
- Keep hands, feet, clothing and long hair away.
- Keep PTO shields and all guards in place.
- Disengage PTO, move the tractor controls to the Neutral position, stop the engine and make sure all rotating components are stopped before leaving the operator’s position.
- Do NOT service the tractor or implement with the PTO engaged.
- Do NOT service the implement in a raised position unless properly blocked and with all rotating components stopped.
- Disengage PTO for road travel.

1. Disconnect the PTO driveline from the tractor and fully slide the driveline sections together (retracted).
2. Measure the retracted (compressed) length of the PTO driveline between the bases of the plastic guards.
3. Multiply the retracted driveline length by 1.667 to determine the PTO driveline Maximum Operating Length. (i.e.: 25.5 in. (647.7 mm) x 1.667= 42.5 in. (1079.7 mm) Maximum Operating Length).
4. Attach the PTO driveline to the tractor PTO output shaft.
5. Enter the operator’s position. (See “Entering The Operator’s Position” in the Operation section)

1. With the PTO driveline attached, position the three-point implement to where the telescoping PTO driveline is at its maximum operating extension.
2. Stop the engine and leave the operator’s position. Make sure the PTO driveline and all rotating components have come to a complete stop before leaving the operator’s position.
3. Measure the length of the PTO driveline between the bases of the plastic shields to determine the maximum operating length [Figure 16].

If the measured maximum operating length is less than the Maximum Operating Length calculation (from Step 3), the PTO driveline has adequate engagement

If the measured maximum operating length is equal to or more than the Maximum Operating Length calculation (from Step 3), the PTO driveline does not have adequate engagement and should be replaced with a longer driveline. See your Farm King dealer for available PTO drivelines.

**Figure 16**

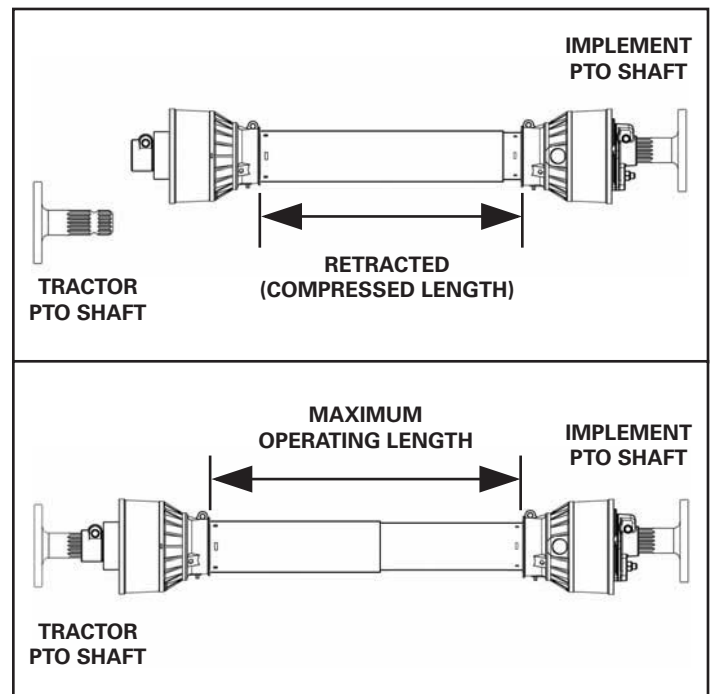

### Connecting Hydraulic Hoses



#### HIGH PRESSURE FLUID HAZARD

To prevent serious injury or death from high pressure fluid:

- Relieve pressure on system before repairing or adjusting.
- Wear proper hand and eye protection when searching for leaks. Use wood or cardboard instead of hands.
- Keep all components in good repair.



Contain and dispose of any oil leakage in an environmentally safe manner.

Thoroughly clean the quick couplers before making connections. Dirt can quickly damage the system.

**NOTE:** Make sure the quick couplers are fully engaged. If the quick couplers do not fully engage, check to see that the couplers are the same size and type.

*To Connect:*

**Figure 17**

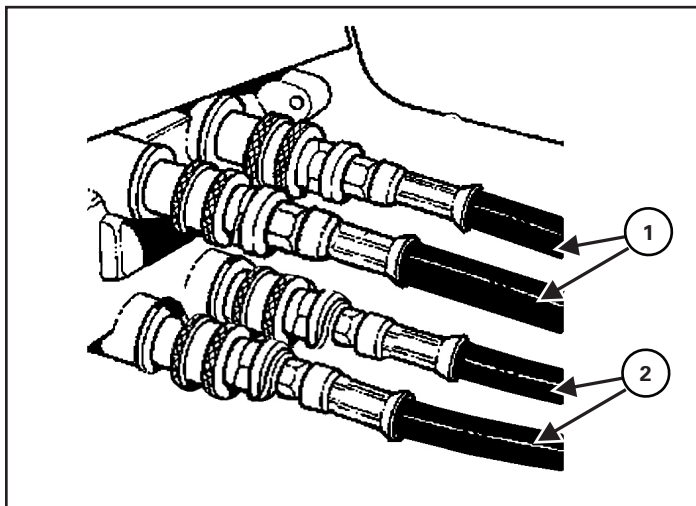

Pull back on the collar of the female coupler, push couplers together, release the collar when the couplers are fully engaged and locked [Figure 17].

Install the two lift cylinder quick coupler hose (Item 1) [Figure 17].

Install the two valve block quick coupler hoses (Item 2) [Figure 17].

*To Disconnect:*

Pull back on the collar and pull the male coupler out to disconnect.

Lower jack until weight of equipment is resting on tractor drawbar. Pull lock pin on jack and remove. Mount jack to storage bracket and secure with lock pin.

## AUGER OPERATION

### Hopper Operation



Never operate the winch or hopper mover when the PTO is engaged.

Enter the tractor and start the engine.

Engage the hydraulic circuit for the hopper / winch control valve on the intake box. Run the tractor engine at low idle.

Figure 18

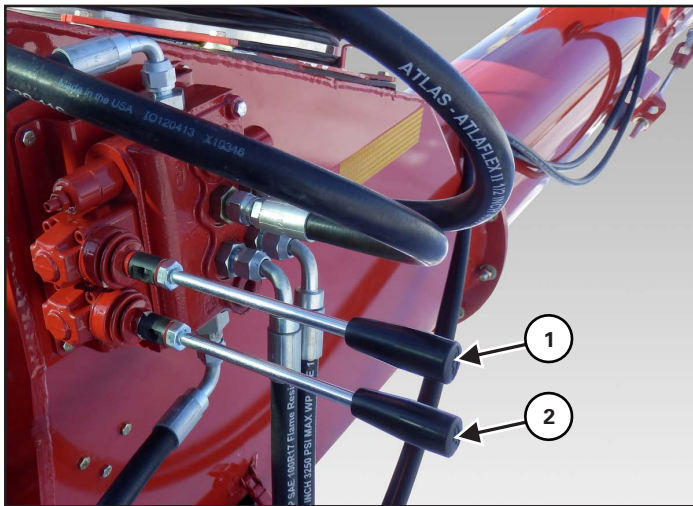

Move the lever (Item 1) to the right (away from the hitch) to move the hopper to the right. Move the lever to the left (towards the hitch) to move the hopper to the left [Figure 18].

Move the lever (Item 2) to the left (towards the hitch) to raise the boom cable (wind cable). Move the lever to the right (away from the hitch) to lower the boom cable (unwind cable) [Figure 18].



Always maintain a minimum of three wraps of cable on the drum of the winch.

## Adjusting Flow Control Valve

Figure 19

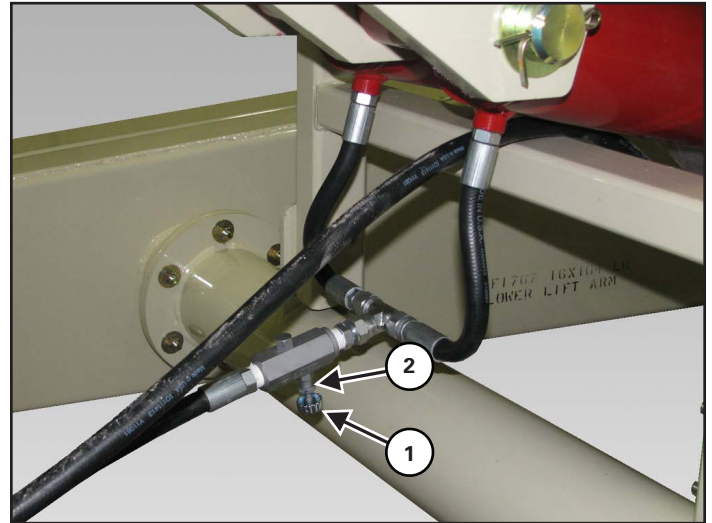

Turn the knob (Item 1) on the flow control valve "IN" to decrease the speed the auger lowers. Turn the knob "OUT" to increase the speed the auger lowers [Figure 19].

Loosen the nut (Item 2) and turn the knob all the way in (tight). The approximate initial setting should be 3-1/2 turns out from the tight position. When set, re-tighten nut to set position [Figure 19].



Be sure that the valve is slightly open before raising the first time or auger will not lower.

## Auger Placement



# DANGER

## ELECTROCUTION HAZARD

To prevent serious injury or death from electrocution:

- Be aware of overhead power lines.
- Keep away from power lines when unloading and assembling the auger.
- Electrocution can occur without direct contact.



# CAUTION

Do not operate the unit before reading and understanding the Operator Manual.

Keep all safety devices in place.

Keep off the equipment at all times.

Keep hands, feet and clothing away from moving parts while in operation.

Make certain everyone is clear of the equipment before applying power or moving the machine.

Do not adjust, service, lubricate, clean, unclog or move the mechanism until all power is shut off.

While in operation, always support the discharge end or provide adequate anchoring of the intake end to prevent sudden tipping.

Disconnect power of electrical driven units before resetting motor overloads.

To avoid tipping, make sure auger is empty before attempting to move.

Keep wheels of undercarriage level and on firm ground.

Lower unit to the recommended transport position before transporting.



# IMPORTANT

Do not raise the main auger higher than 35° before lowering the intake auger or interference between the intake auger and the intake box will occur.

Never attempt to raise or lower the auger during operation.

Verify wheels are free to move.

Operate the auger at a 35° angle. Do not exceed a 42° angle.

Angles above 35°, decreases auger capacity.

Some types of fertilizer may cause accelerated wear and corrosion as well as added stress on lift components due to additional load.

Use of fertilizer can affect warranty.



# IMPORTANT

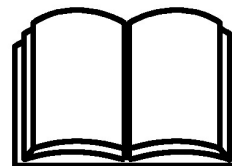

Follow the instructions in your tractor's operation manual for the correct operating instructions.

With the main auger in the fully down position, move the auger towards the bin or barn. Position the auger as close as possible to the bin or barn.



**Never place blocks under the wheels to increase the elevation of the auger.**

Stop the tractor and engage the parking brake. Engage the tractor's hydraulics. Run the tractor engine at low idle.

**Figure 20**

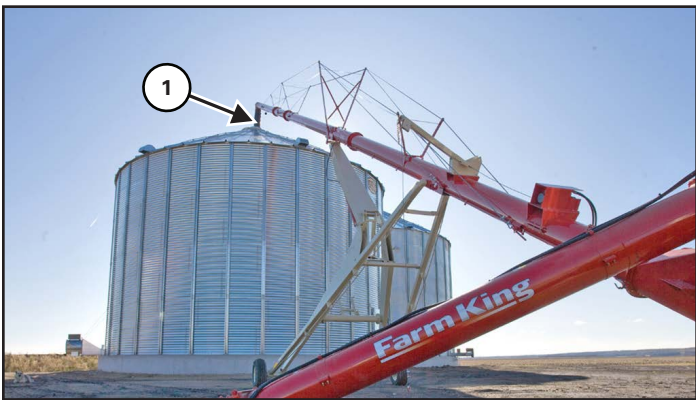

Using the tractor controls, slowly raise the main auger to the desired height (do not exceed a 42° angle).



**Keep wheels of undercarriage level and on firm ground. Raise the auger to the desired height and back the auger into position. Do not support the auger on the bin. As the auger becomes full, the weight may cause damage to the underside of the auger or to the bin.**

Back the auger into position above the bin. Lower the auger until the downspout (Item 1) enters the bin [Figure 20].

Engage the tractor's parking brake, stop the engine and exit the tractor.

**Unloading Belly Dump Units**

**Figure 21**

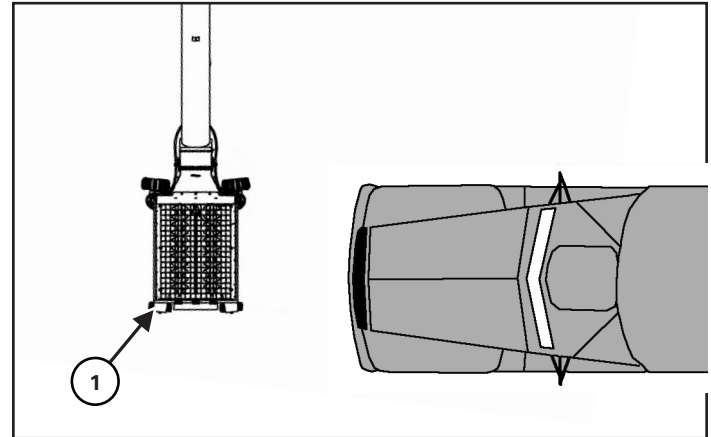

Move the hopper (Item 1) out at a 90° angle from the auger [Figure 21].

Move the belly dump unit into position, centered on the hopper.

Mark the path of the belly dump unit for future units to unload and maintain the proper distance from the auger to allow adequate space for the hopper to be moved in and out without interference.

Move the hopper mover lever left or right to move the hopper in towards the auger, away from vehicle traffic.

**Figure 22**

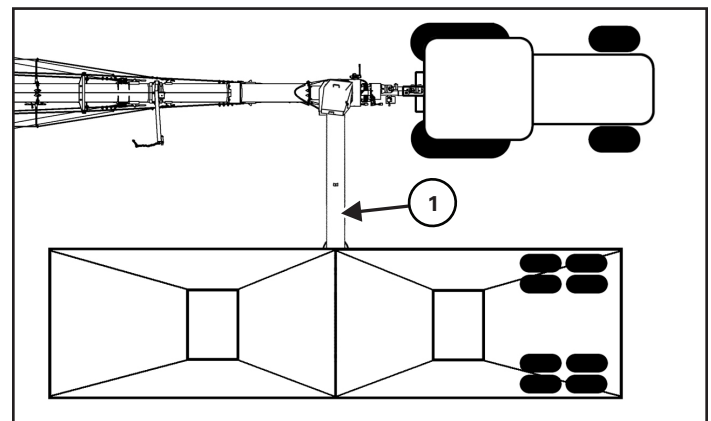

Move the belly dump unit straight forward until centered on the intake auger pivot. Stop the belly dump unit.

Move the hopper (Item 1) under the belly dump unit [Figure 22].

**Figure 23**

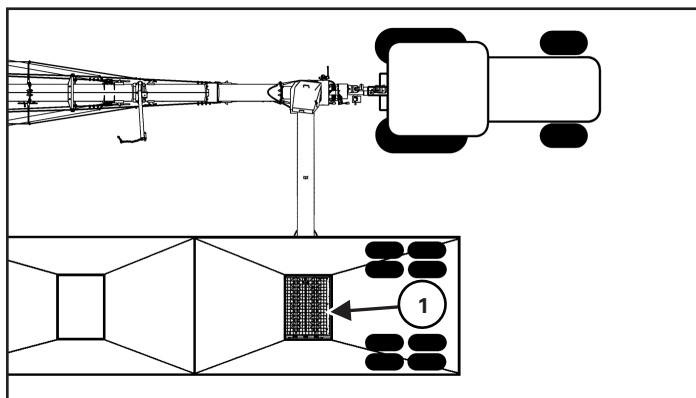

Move the belly dump unit forward until the rear compartment is directly over the hopper (Item 1) [Figure 23].



**AVOID INJURY OR DEATH**

**Do NOT exceed 1000 RPM PTO.**

**Keep PTO shields and all guards in place.**

**Keep away from moving parts.**

**Keep bystanders away.**

With tractor running at a low idle, engage the tractor PTO slowly to start the auger. Increase engine RPM (do not exceed 1000 RPM PTO speed).

Slowly open the compartment gate.

Adjust gate until the hopper augers and intake auger can move grain to the main auger without overflowing the hopper.

When the rear compartment is empty, close the gate, disengage the PTO and lower engine RPM speed.

**Figure 24**

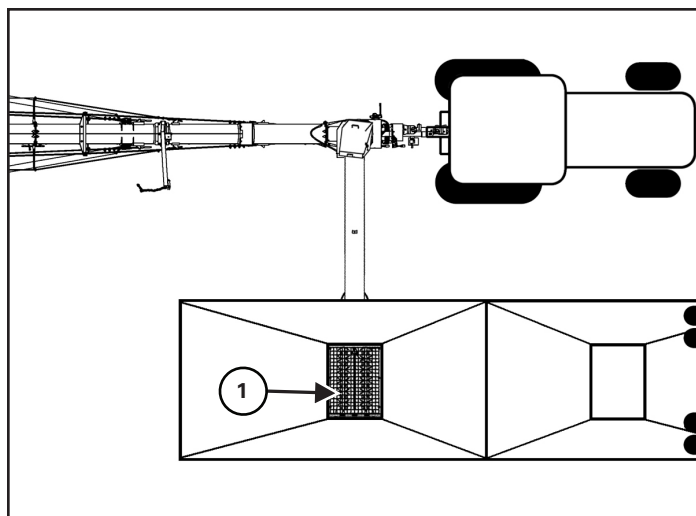

Move the belly dump unit back until the front compartment is directly over the hopper (Item 1) [Figure 24].

With tractor running at a low idle, engage the tractor PTO slowly to start the auger. Increase engine RPM (do not exceed 1000 RPM speed).

Slowly open the compartment gate.

Adjust gate until the hopper augers and intake auger can move grain to the main auger without overflowing the hopper.

When the front compartment is empty, close the gate, disengage the PTO and lower engine RPM speed.

Move the hopper in the desired position away from vehicle traffic.

Disengage the tractor hydraulics and exit the tractor.

**Unloading Rear And Side Dump Units**

**Figure 25**

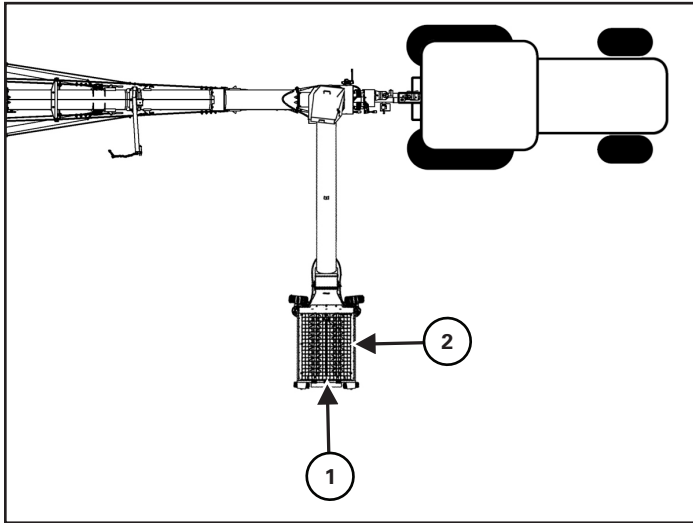

Move the hopper out at a 90° angle from the auger.

Move the rear dump unit into the unloading position at the end of the hopper (Item 1) or on the tractor side of the hopper (Item 2) [Figure 25].

Move the side dump unit into the unloading position at the end of the hopper (Item 1) [Figure 25].

Position the gate of the dumping unit over the hopper (as close to the center of the hopper as possible).

Stop the dumping unit and engage the parking brake (if equipped).

 **WARNING**

**AVOID INJURY OR DEATH**

**Do NOT exceed 1000 RPM PTO.**

**Keep PTO shields and all guards in place.**

**Keep away from moving parts.**

**Keep bystanders away.**

With tractor running at a low idle, engage the tractor PTO slowly to start the auger. Increase engine RPM (do not exceed 1000 RPM speed).

Slowly open the gate on the dumping unit.

Adjust gate until the hopper augers and intake auger can move grain to the main auger without overflowing the hopper.

When the unit is empty, close the gate, disengage the PTO and lower engine RPM speed.

Disengage the tractor hydraulics and exit the tractor.

## TRANSPORTATION

### Requirements



### ELECTROCUTION HAZARD

To prevent serious injury or death from electrocution:

- Be aware of overhead power lines.
- Keep away from power lines when transporting the auger.
- Electrocution can occur without direct contact.



Use of an unapproved hitch or tractor / tow vehicle can result in loss of control, leading to serious injury or death. Tractor / tow vehicle and hitch must have the rated capacity to tow equipment.



Do not operate the unit before reading and understanding the Operator Manual.

Make certain everyone is clear of the equipment before applying power or moving the machine.

To avoid tipping, make sure auger is empty before attempting to move.

Keep wheels of undercarriage level and on firm ground.

Lower unit to the recommended transport position before transporting.

Disconnect PTO driveline from the tractor before moving or transporting.



Never exceed 20 mph (32 kph).

Do not move or transport the auger unless the hopper and intake auger are in the raised / transport position and securely fastened before transporting.

Comply with federal, state, local and provincial laws regarding the transport of farm equipment on public roadways.

Verify that the tractor / tow vehicle are approved for transporting the equipment and that the equipment is securely attached to the tractor / tow vehicle.

Verify safety chain is installed and properly connected before transporting equipment.

Verify that the SMV (Slow Moving Vehicle) emblem, all lights and reflectors are clean and visible.

Always attach a red flag to the end of the auger when transporting on roads.

Disconnect the PTO driveline from the tractor before transporting.

#### Transporting Guidelines

The ratio of the tractor / tow vehicle weight to the loaded equipment weight plays an important role in defining acceptable travel speed.

TRAVEL SPEED - Acceptable travel speed.

WEIGHT RATIO - Weight of fully equipped or loaded implement(s) relative to weight of tractor / tow vehicle.

TRAVEL SPEED	WEIGHT RATIO
Up to 20 mph (32 kph)	1 to 1 (or less)
Up to 10 mph (16 kph)	2 to 1 (or less)
DO NOT TOW	More than 2 to 1

**Transporting Procedure**

Remove all supports on the discharge end and anchorage from the intake end (if required).

Enter the tractor, start the engine and engage the tractor’s hydraulics.

Engage the hydraulic circuit for the hopper / winch control valve on the intake box. Run the tractor engine at low idle.

**Figure 26**

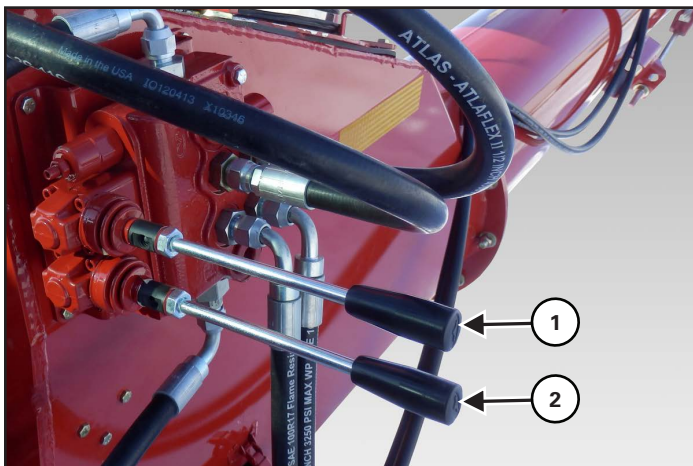

Move the lever (Item 1) to the right (away from the hitch) to move the hopper to the right (toward the auger) until the boom cable can be installed [Figure 26].

Move the lever (Item 2) to the right (away from the hitch) to lower the boom cable (unwind cable) [Figure 26].

**Figure 27**

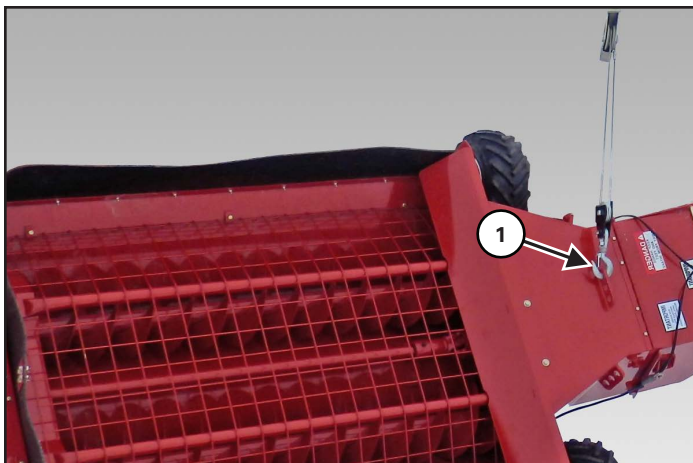

Install the boom cable (Item 1) onto the hopper [Figure 27].

Move the lever (Item 2) to the left (towards the hitch) to raise the boom cable (wind cable) [Figure 27].

Raise the hopper until the transport chain can be installed.

## WARNING

The weight of the hopper and intake auger assembly must be supported by the transport chain, whenever the auger is moved. If the weight of the intake auger is on the winch, the winch may be damaged during transport.

**Figure 28**

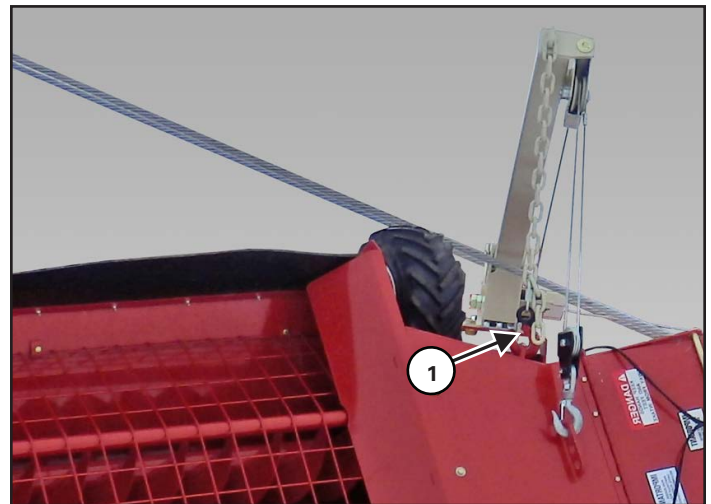

Install the transport chain (Item 1) onto the hopper [Figure 28].

Lower the hopper until the transport chain is supporting the weight of the hopper and intake auger.

Enter the tractor, using the tractor controls, slowly raise the main auger until the discharge spout is clear from the bin.

Release the parking brake and move the tractor and auger forward (away from the bin) until there is adequate space for the auger to be lowered into the transport position.

Stop the tractor and engage the parking brake.

**! IMPORTANT**

Always lower the auger before transporting and allow the weight of the auger to rest on the undercarriage and not the hydraulic cylinders.

Figure 29

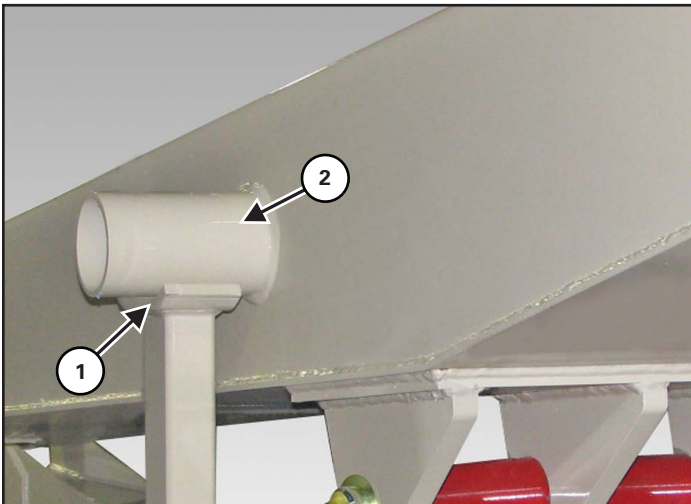

Fully lower the auger until the upper lift arm (Item 1) contacts the cradle rest (Item 2) (both sides).

**! WARNING**

**AVOID INJURY OR DEATH**

Before you leave the operator's position:

- Always park on a flat level surface.
- Place all controls in NEUTRAL.
- Engage the park brake.
- Stop the engine and remove the key.
- Wait for all moving parts to stop.

Engage the tractor's parking brake, stop the engine and exit the tractor.

Figure 30

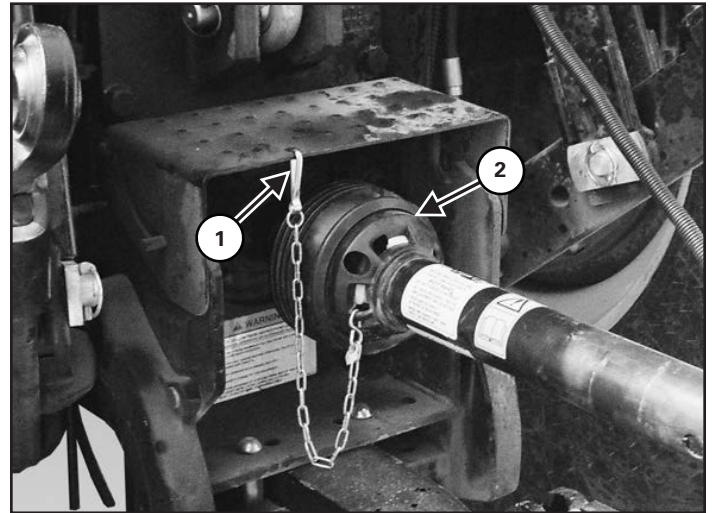

Remove the PTO driveline safety chain (Item 1). Retract the collar (Item 2) and slide the PTO driveline off the tractor PTO shaft [Figure 30].

Figure 31

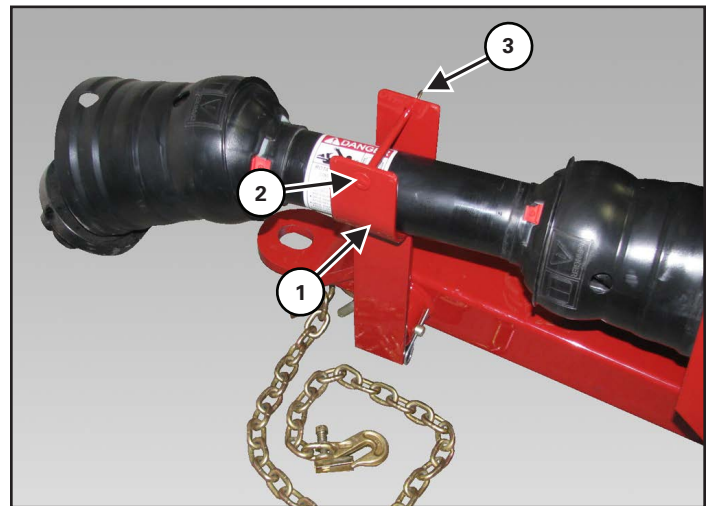

Place the PTO driveline into the PTO holder (Item 1). Install the clevis pin (Item 2) and hairpin clip (Item 3) [Figure 31].

Verify that the auger is securely fastened to the tractor / tow vehicle and that the hitch safety chain is properly attached to the auger and tractor / tow vehicle.

Verify that the SMV (Slow Moving Vehicle) sign is attached and visible.

Verify that the amber lights are clean and operating correctly.

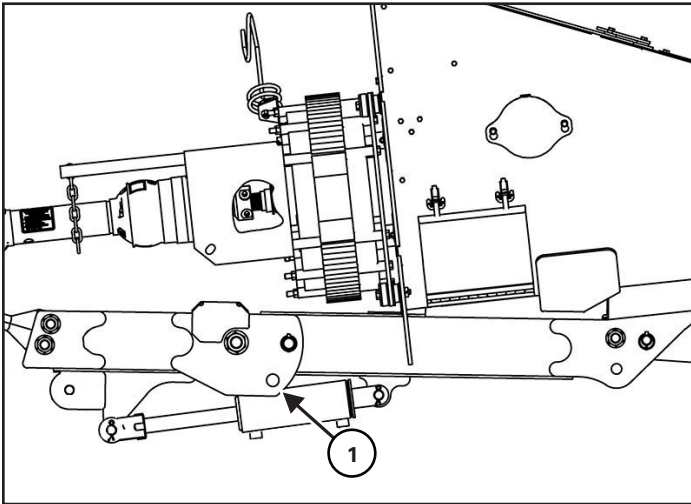
**Figure 32**

Remove the hitch locking pin.

Operate the proper tractor hydraulic control to adjust the auger hitch to align holes and install hitch locking pin (Item 1) in transport position [Figure 32].



## **WARNING**

### **AVOID INJURY OR DEATH**

**Do NOT** operate equipment without locking pins in place.

---

# Farm King



# MAINTENANCE

TRUBLESHOOTING.....	49
Chart.....	49
SERVICE SCHEDULE.....	50
Maintenance Intervals.....	50
LUBRICATION.....	51
Recommendations.....	51
Undercarriage Locations.....	51
Tube Locations.....	54
Hopper Locations.....	55
PTO Locations.....	56
GEARBOXES.....	57
M2000 Helical Gearbox.....	57
4168 Lower Gearbox.....	57
4168 Upper Gearbox.....	58
AXLES.....	59
Wheel Lug Nut Torque.....	59
Tire / Wheel Replacement.....	59
Tire Pressure.....	59
BRIDGING.....	60
Cable Inspection.....	60
Lubrication.....	60
Cleaning.....	60
Cable Tension Adjustment.....	60
Trusses Inspection.....	63
STORAGE AND RETURN TO SERVICE.....	64
Storage.....	64
Return To Service.....	64
SAFETY SIGN (DECAL) INSTALLATION.....	64
ELECTRIC HOPPER CONTROL BOX TROUBLESHOOTING.....	65
Hopper Will Not Move Left Or Right.....	65
Hopper Will Only Move In One Direction.....	65
Remote Control Functions Correctly But The Move-Left/Right Switches On The Box Do Not.....	65
Winch Will Not Raise Or Lower.....	66

Winch Will Only Rotate In One Direction..... 66

Remote Control Functions Correctly But The Raise/Lower Switches On The Box Do Not..... 66

**ELECTRIC HOPPER REMOTE OPERATION..... 67**

    Operation..... 67

    Recharging..... 67

    Indicator Lights..... 67

    Teach ID Code..... 67

**PART IDENTIFICATION - CONTROL BOX SZ000997..... 68**

## TROUBLESHOOTING

### Chart



# WARNING

Instructions are necessary before operating or servicing equipment. Read and understand the Operator And Parts Manual and safety signs (decals) on equipment. Follow warnings and instructions in the manuals when making repairs, adjustments or servicing. Check for correct function after adjustments, repairs or service. Untrained operators and failure to follow instructions can cause injury or death.

**NOTE:** If a problem is encountered that is difficult to solve, even after having read through this troubleshooting section, please call your local Farm King dealer. Before you call, please have this Operator And Parts Manual and the serial number of your machine at hand.

PROBLEM	CAUSE	CORRECTION
Cannot start augers.	Plugged auger or obstruction.	Shutoff tractor and disconnect the PTO. Remove obstruction.
	Bearing failure.	Check bearings and replace if required.
Grain flow is too fast.	Discharge gate(s) open too far.	Close the gate(s) to allow a slower grain flow to the hopper / intake auger.
Grain flow is too slow.	Discharge gate(s) not open enough.	Open the gate(s) to allow a faster grain flow to the hopper intake auger.
	Tractor RPM set to low.	Raise tractor RPM to proper setting.
Lights do not function.	Loose connection.	Check electrical connection at tractor.
	Faulty harness or wire.	Check for broken wires.
	Faulty tractor circuit.	Check tractor light circuit.
Excessive vibration.	PTO not connected properly.	Connect the CV side of the PTO to the implement.

## SERVICE SCHEDULE

### Maintenance Intervals

Maintenance work must be done at regular intervals. Failure to do so will result in excessive wear and early failures. The service schedule is a guide for correct maintenance of the equipment.



## WARNING

Instructions are necessary before operating or servicing equipment. Read and understand the Operator and Parts Manual and safety signs (decals) on equipment. Follow warnings and instructions in the manuals when making repairs, adjustments or servicing. Check for correct function after adjustments, repairs or service. Untrained operators and failure to follow instructions can cause injury or death.

#	DESCRIPTION	SERVICE PROCEDURES					
		Check	Clean	Lube	Change	Adjust	Drain
<b>Daily Maintenance (or every 8 hours)</b>							
1	CV Joints, U-Joints and Bearings			•			
2	PTO Driveline			•			
3	Universal Joint (Front)			•			
4	Lower & Upper Lift Arm Pivots			•			
5	Hopper Drive Shaft & U-Joints			•			
6	Intake Auger Shaft & U-Joints			•			
7	Dual Auger Hopper Drive Chains			•			
<b>Weekly (or every 50 hours)</b>							
8	Lower Intake Auger Gearbox Oil Level	•					
9	Upper Intake Auger Gearbox Oil Level	•					
10	Main Gearbox	•					
11	Wheel Lug Nut Torque	•					
12	Winch Cable	•					
13	Bridging Cable Tension	•					
<b>Semi-Annually (or every 250 hours)</b>							
14	Bridging Cables	•	•			•	
15	Backsaver Auger		•				
<b>Annually (or every 500 hours)</b>							
16	Lower Intake Auger Gearbox Oil				•		
17	Upper Intake Auger Gearbox Oil				•		
18	Main Gearbox				•		
19	Main Tubes	•					

## LUBRICATION

### Recommendations

Always use a good quality multi-purpose / lithium base grease when lubricating the equipment.

- Always use a hand-held grease gun.
- Clean fitting before greasing, to avoid injecting dirt and grit.
- Replace and repair broken fittings immediately.
- If fittings will not take grease, remove and clean thoroughly. Replace fitting if necessary.



Fluid such as engine oil, hydraulic fluid, coolants, grease, etc. must be disposed of in an environmentally safe manner. Some regulations require that certain spills and leaks on the ground must be cleaned in a specific manner. See local, state and federal regulations for the correct disposal.

### Undercarriage Locations

Lubricate the following grease locations daily or **EVERY 8 HOURS**:

**Figure 33**

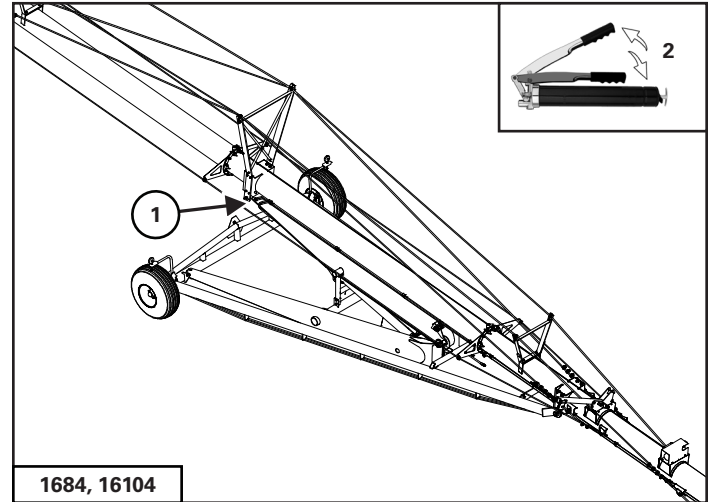

Models 1684, 16104: Apply two pumps of grease to the upper undercarriage pivot (Item 1) [Figure 33].

**Figure 34**

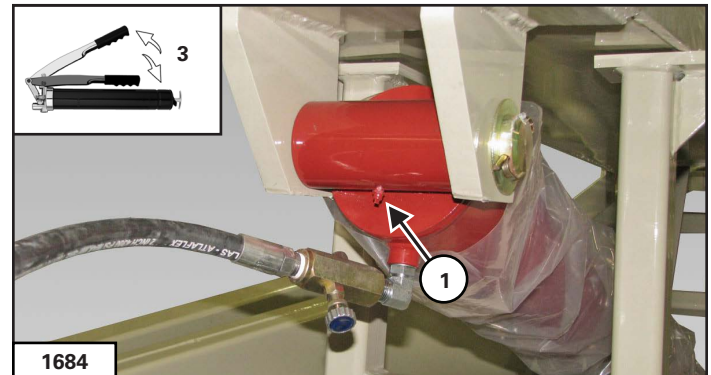

Model 1684: Apply three pumps of grease to the base end of the lift cylinder (Item 1) [Figure 34].

Figure 35

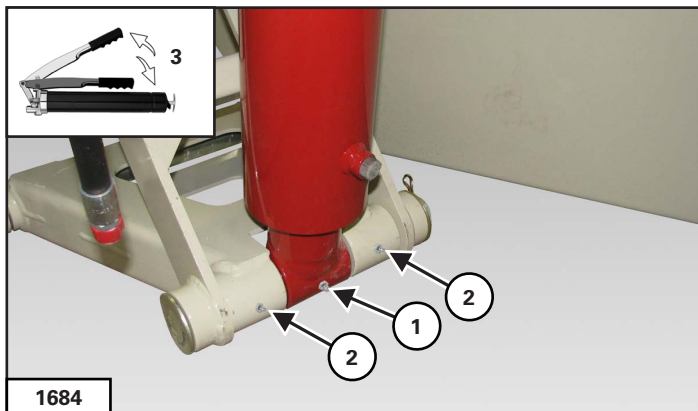

Model 1684: Apply three pumps of grease to the rod end of the lift cylinder (Item 1). Apply three pumps of grease to the connecting link (Item 2) [Figure 35].

Figure 36

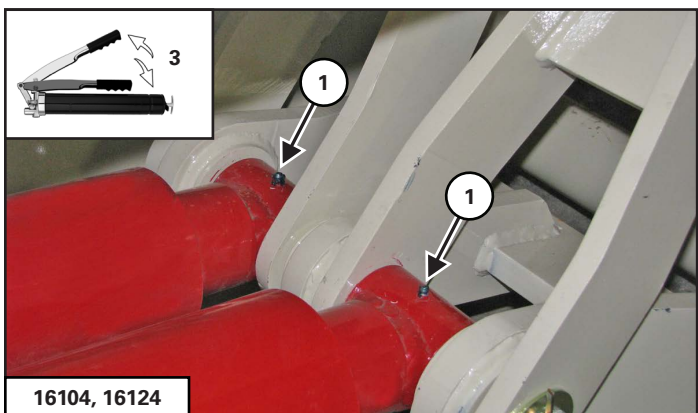

Model 16104, 16124: Apply three pumps of grease to the rod end of each lift cylinder (Item 1) [Figure 36].

Figure 37

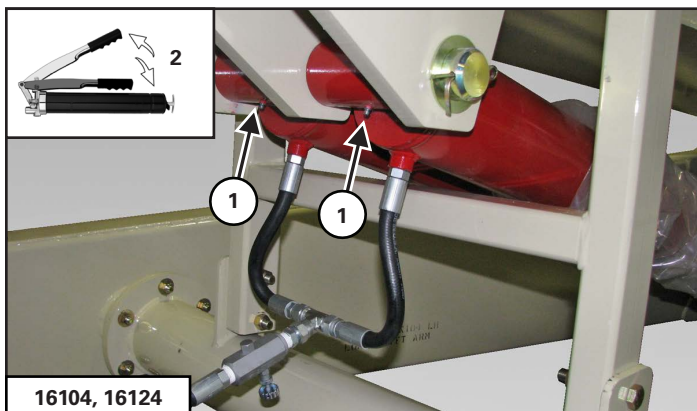

Models 16104, 16124: Apply two pumps of grease to the cylinder base ends (Item 1) [Figure 37].

Figure 38

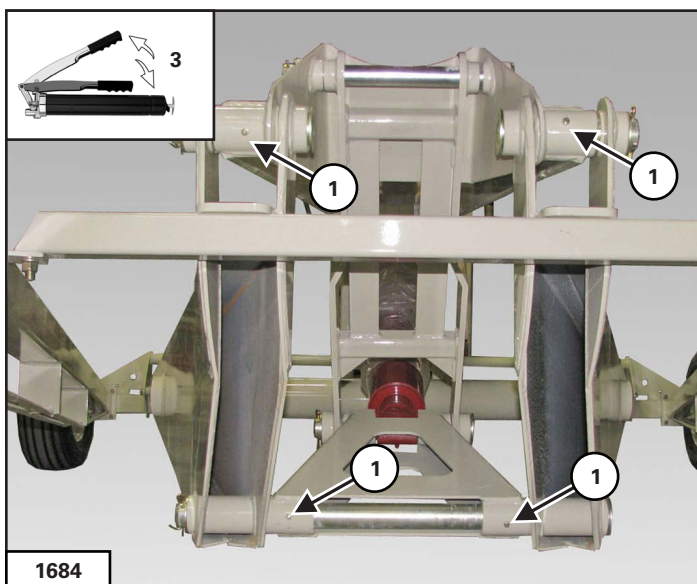

Model 1684: Apply three pumps of grease to the LH & RH lower lift arms (Item 1) [Figure 38].

**Figure 39**

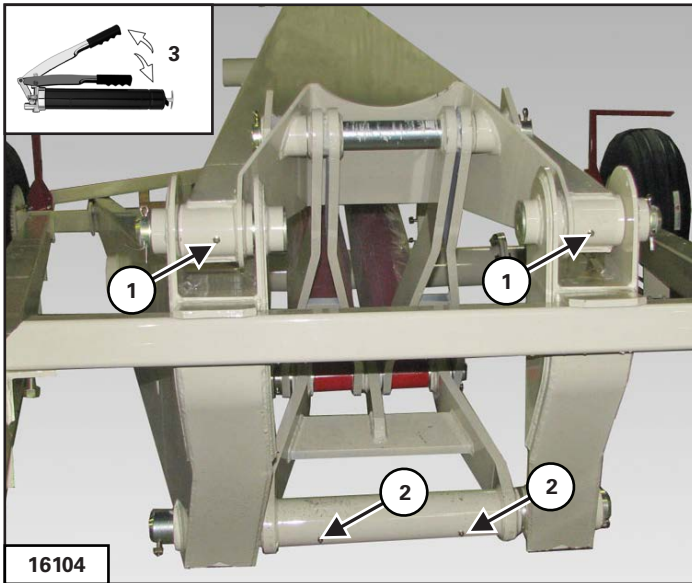

Model 16104: Apply three pumps of grease to the two front upper lift arm pivots (Item 1) and lower link pivot (Item 2) [Figure 39].

**Figure 40**

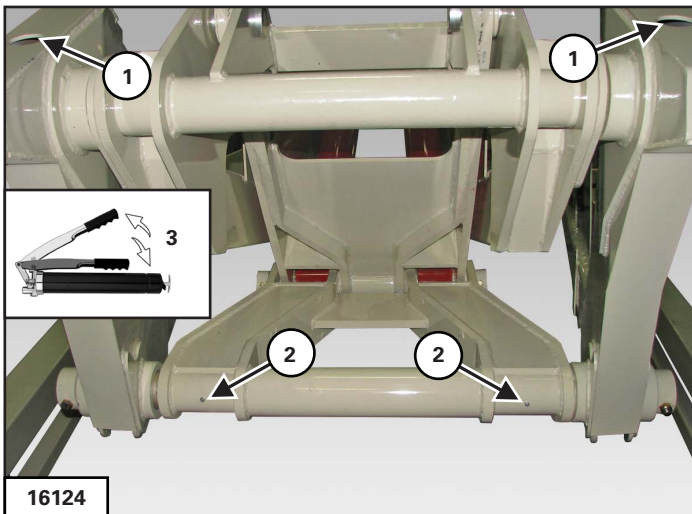

Model 16124: Apply three pumps of grease to the two front upper lift arm pivots (Item 1) and lower pivot yoke (Item 2) [Figure 40].

**Figure 41**

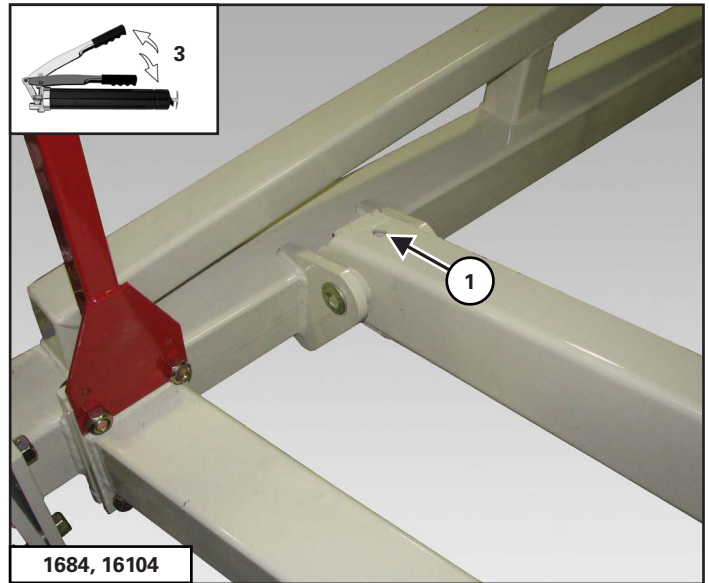

Model 1684, 16104: Apply three pumps of grease to the RH and LH lower lift arm pivots (Item 1) [Figure 41].

**Figure 42**

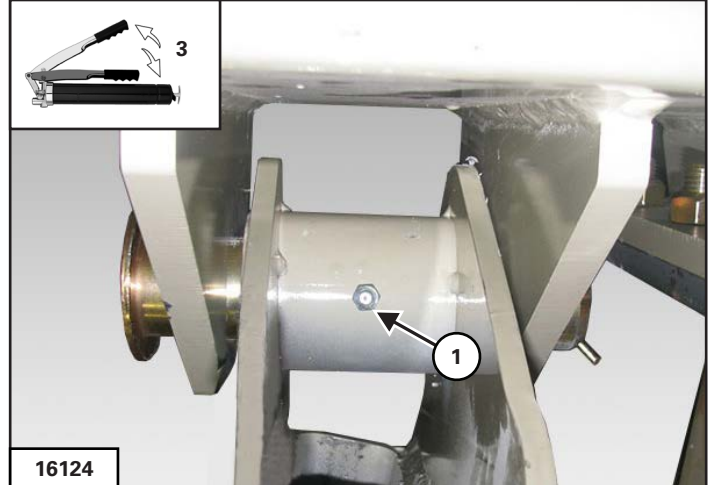

Model 16124: Apply three pumps of grease to the RH and LH lower lift arm pivots (Item 1) [Figure 42].

### Tube Locations

Lubricate the following grease locations daily or **EVERY 8 HOURS**:

**Figure 43**

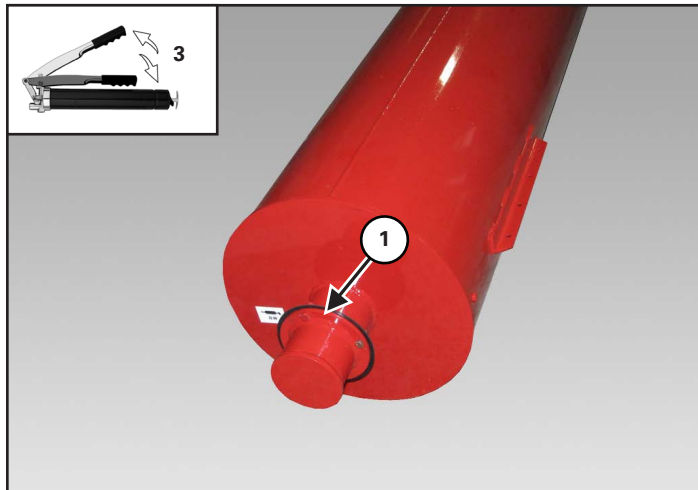

Apply three pumps of grease to the bearings (Item 1) at the end cap on the discharge tube of the auger [Figure 43].

**Figure 44**

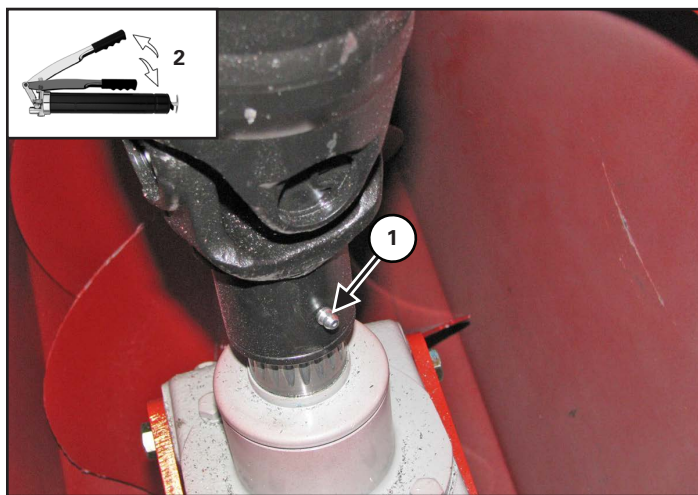

Apply two pumps of grease to the intake double joint (Item 1) [Figure 44].

**Figure 45**

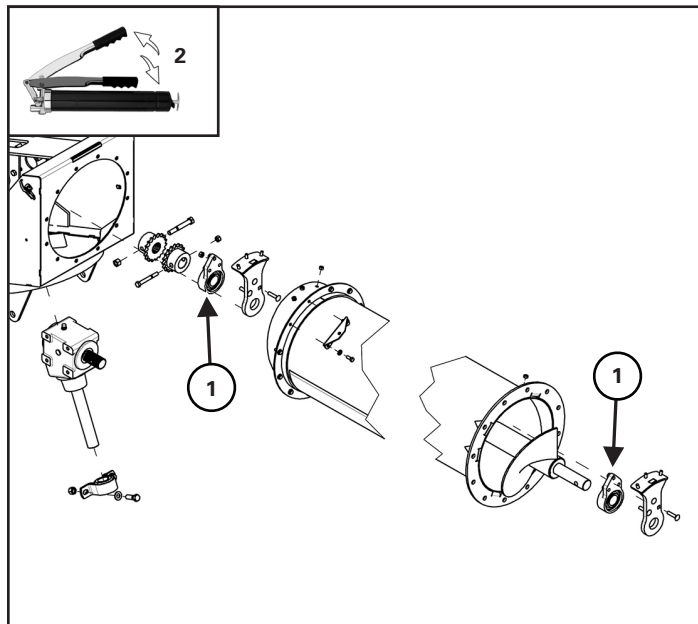

Apply two pumps of grease to the intake tube fighting shaft bearings (Item 1) [Figure 45].

**Hopper Locations**

Lubricate the following grease locations daily or **EVERY 8 HOURS**:

**Figure 46**

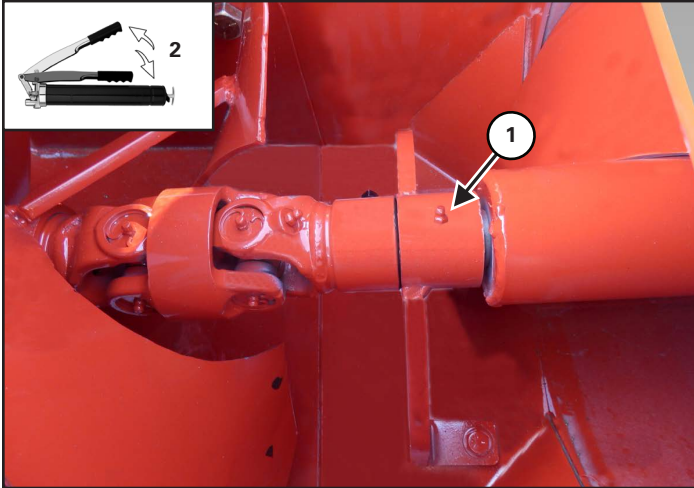

Apply two pumps of grease to the intake auger hanger mount (Item 1) [Figure 46].

**Figure 47**

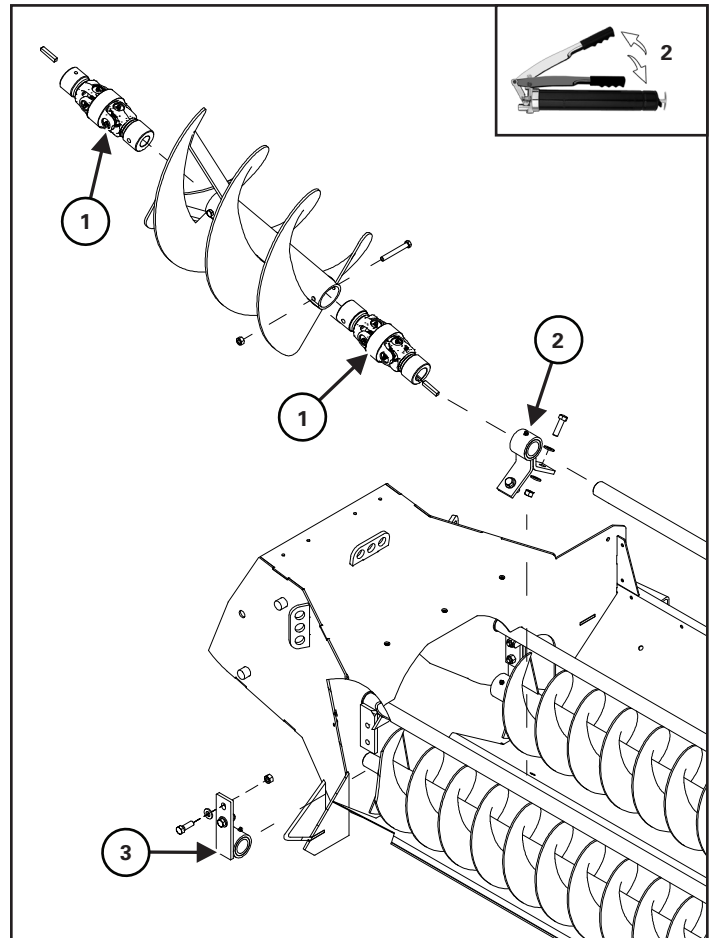

Apply two pumps of grease to the CV joints (Item 1) [Figure 47].

Apply two pumps of grease to the center driveshaft holder (Item 2) [Figure 47].

Apply two pumps of grease to the LH and RH fighting holders (Item 3) [Figure 47].

**Figure 48**

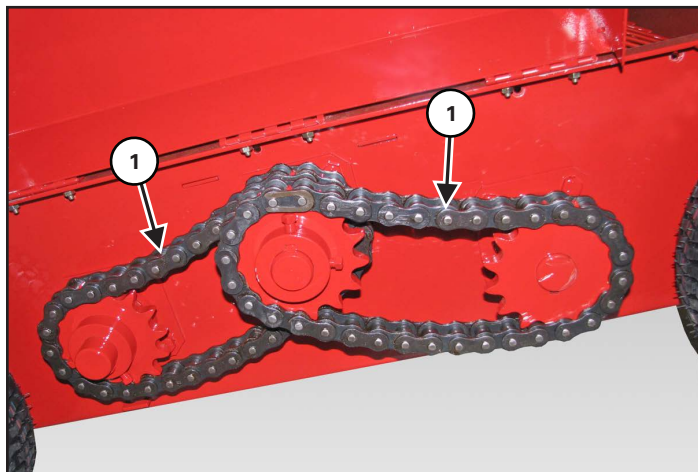

Apply oil to the hopper dual chains (Item 1) [Figure 48].

**PTO Locations**

Lubricate the following grease locations daily or **EVERY 8 HOURS**:

**NOTE:** The PTO shaft is equipped with extended life bearings. Do not over-grease.

**Figure 49**

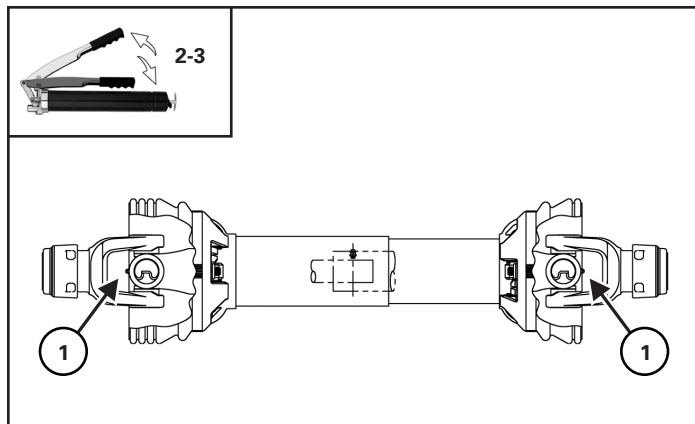

Apply two to three pumps of grease to the cross and bearings (Item 1) on the PTO driveline [Figure 49].

**Figure 50**

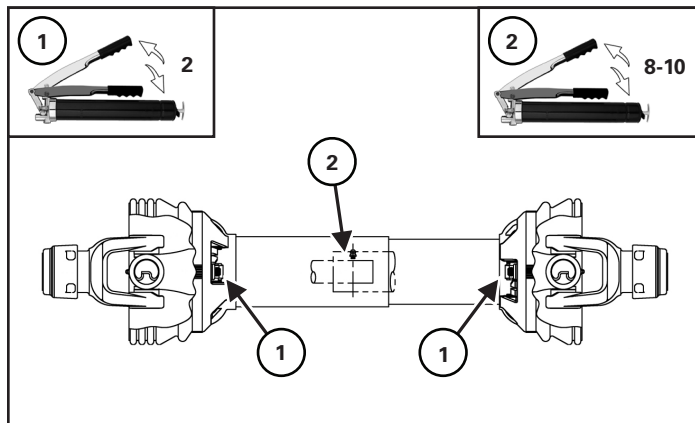

Apply two pumps of grease to the guard bushings (Item 1) [Figure 50].

Apply eight - ten pumps of grease to the telescoping member (Item 2) [Figure 50].

## GEARBOXES

Check gearbox oil levels weekly or **EVERY 50 HOURS**:

### M2000 Helical Gearbox

**Figure 51**

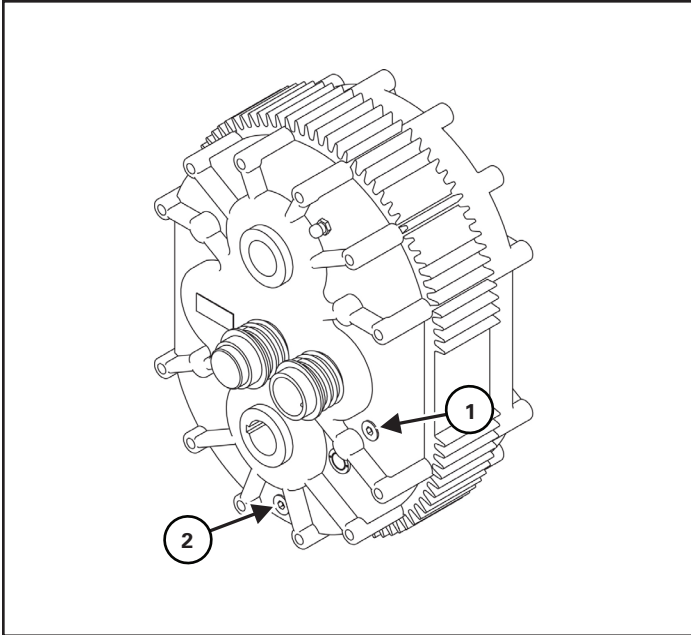

Remove the fill plug (Item 1) from the gearbox. Oil level should be at the bottom of the plug hole **[Figure 51]**.

If the oil level is low, add SAE 75W-90 synthetic gear oil until the oil is at the bottom of the hole.

#### *Changing Gear Oil*

Remove the drain plug (Item 2) and allow all the gear oil to be drained. Re-install drain plug **[Figure 51]**.

Remove the side plug (Item 1) from the gearbox. Fill with SAE 75W-90 synthetic gear oil to the bottom of the plug hole. Re-install fill / side plug **[Figure 51]**.

### 4168 Lower Gearbox

**Figure 52**

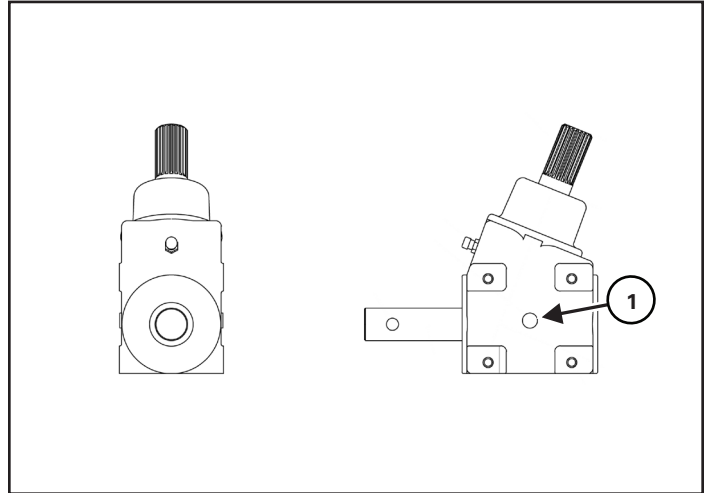

Remove the fill / drain plug (Item 1) from the gearbox. Oil level should be at the bottom of the plug hole **[Figure 52]**.

If the oil level is low, add SAE 75W-90 synthetic gear oil until the oil is at the bottom of the hole.

#### *Changing Gear Oil*

Remove the fill / drain plug (Item 1) and siphon all the gear oil from the gearbox **[Figure 52]**.

Fill with SAE 75W-90 synthetic gear oil to the bottom of the plug hole. Install fill / side plug.

## 4168 Upper Gearbox

Figure 53

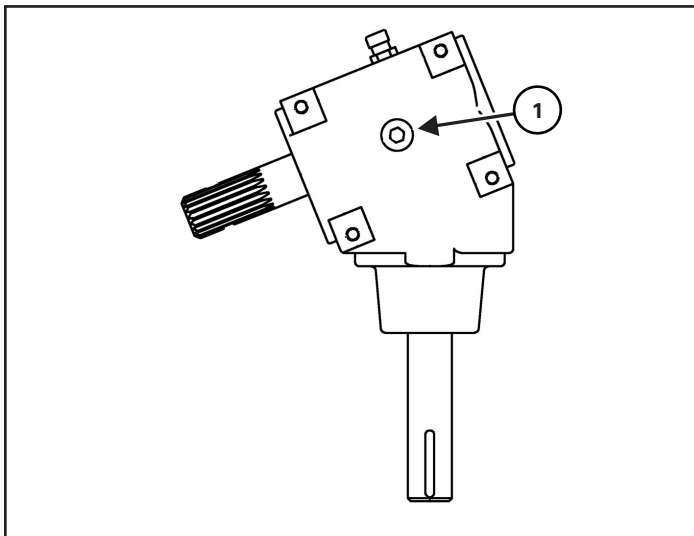

Remove the fill / drain plug (Item 1) from the gearbox. Oil level should be at the bottom of the plug hole **[Figure 53]**.

If the oil level is low, add SAE 75W-90 synthetic gear oil until the oil is at the bottom of the hole.

### *Changing Gear Oil*

Remove the fill / drain plug (Item 1) and siphon all the gear oil from the gearbox **[Figure 53]**.

Fill with SAE 75W-90 synthetic gear oil to the bottom of the plug hole. Install fill / side plug.

### *Cleaning And Inspection*

**NOTE:** Inspect the driveline components, replace all damaged or worn components.

Use solvent to clean the shaft and tube. Use compressed air to dry and remove excess solvent from the parts.

Apply a light coat of grease to the shaft and the tube end.

Use solvent to clean the slide collars, yokes, crosses and bearings. Use compressed air to dry the parts.

Apply a light coat of grease to the inside of the slide collars.

## AXLES

### Wheel Lug Nut Torque

Check the torque on wheel lug nuts daily or **EVERY 8 HOURS**:

Ten Bolt Hub:

- Tighten wheel nuts to 462 lb. ft. (626 N•m)

Eight Bolt Hub

- Tighten wheel nuts to 264 lb. ft. (358 N•m)

Six Bolt Hub

- Tighten wheel nuts to 133 lb. ft. (180 N•m)

### Tire / Wheel Replacement

Empty the Backsaver Auger (if required).



## WARNING

### AVOID INJURY OR DEATH

**Before you leave the operator's position:**

- Always park on a flat level surface.
- Place all controls in **NEUTRAL**.
- Engage the park brake.
- Stop the engine and remove the key.
- Wait for all moving parts to stop.

Park the tractor / equipment on a flat level surface.

Place all controls in neutral, engage the park brake, stop the engine and wait for all moving parts to stop. Leave the operator's position.

Place chock blocks behind and in front the auger tire.

Place a jack under the axle frame on the side the wheel is to be replaced. Raise the jack until the wheel is slightly off the ground.

NOTE: Place blocks under the frame to help secure the auger when wheel is raised off the ground.

**Figure 54**

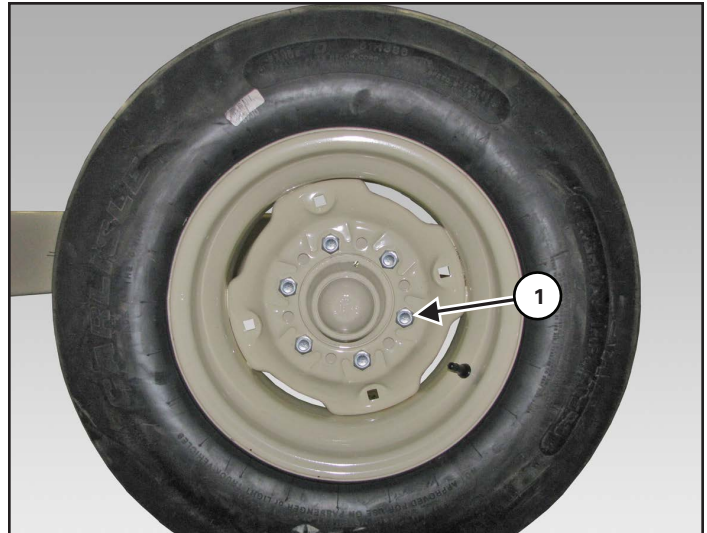

Install the tire with the valve stem facing out (both sides). Install the six wheel bolts (Item 1) (both sides) [Figure 54].

Tighten wheel nuts in a criss-cross pattern. Tighten wheel nuts to proper torque.

Lower the axle and tires to the ground. Remove the strap and lifting device.

### Tire Pressure

Check the tire pressure daily or **EVERY 8 HOURS**:

Inflate tires to manufacturer recommended pressure.



## CAUTION



**When inflating tires, use a clip-on chuck and extension hose long enough to allow you to stand to one side and NOT in front of or over the tire assembly.**

## BRIDGING

### Cable Inspection



## IMPORTANT

**Always wear the proper hand and eye protection when serving the equipment.**

Regularly check the tightness of all cable clamps to avoid slipping. Inspect cables regularly for damage, wear or corrosion.

Cable inspections should be done at the beginning of operation and directly after the auger has been towed or transported.

Use a piece of cloth or rag to slide across the cables to locate broken or frayed wires. Replace cables as needed.

### Lubrication

To prevent damage by corrosion, the cables should be kept well lubricated.

### Cleaning

Periodic cleaning of cables by using a stiff brush and kerosene or with compressed air or live steam and re-lubricating will help to lengthen cable life and reduce abrasion and wear on sheaves and drums.

### Cable Tension Adjustment

Check cable tension weekly or **EVERY 50 HOURS**:



## IMPORTANT

**Completely unload auger before adjusting bridging cables.**

**Figure 55**

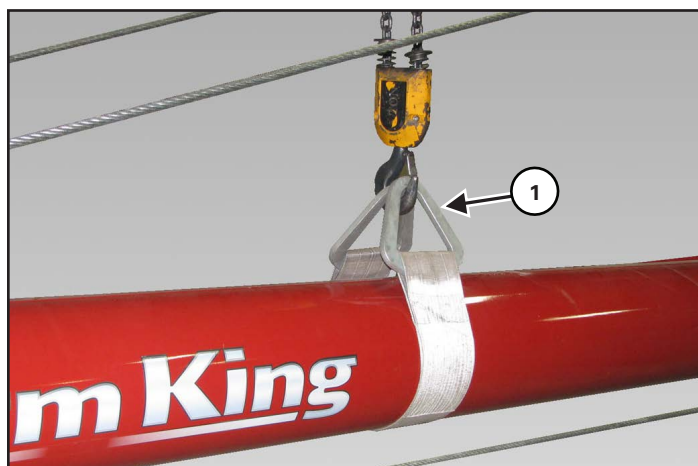

Install a strap (Item 1) around the tube [Figure 55].

Connect the strap to an approved lifting device.

Raise the lifting device, until tight, to support the auger tube(s).



## WARNING

### AVOID INJURY OR DEATH

**Before you leave the operator's position:**

- Always park on a flat level surface.
- Fully lower the main auger into the transport position.
- Disconnect the PTO driveline.
- Support the main auger tube with an approved lifting device.
- Chock tires.

**Top Cables - Models 1684, 16104**

**Figure 56**

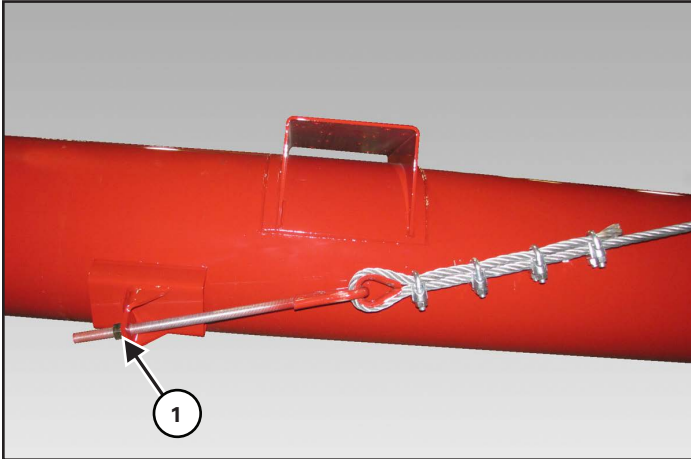

*Bottom Tube Adjustment Bolt*

Loosen all cable clamps along the cable being tightened.

Tighten the nut (Item 1) of the desired bridging cable on tube **[Figure 56]**.

Tighten both left and right cables evenly.

Tighten the upper bridging cable until the discharge end of the tube bows up slightly.

Tighten the lower bridging cable to hold the tube in the slightly raised position.

After tightening the lower and upper cables, check that the auger tube is straight. No bend right or left.

!

IMPORTANT

**If the nut is fully tightened and bottoms out against the eye of the adjustment bolt, the top tube adjustment bracket will need to be adjusted.**

**Do not remove the nut from the adjustment bolt.**

After adjusting the cable(s), tighten all cable clamps along the cable(s).

**Figure 57**

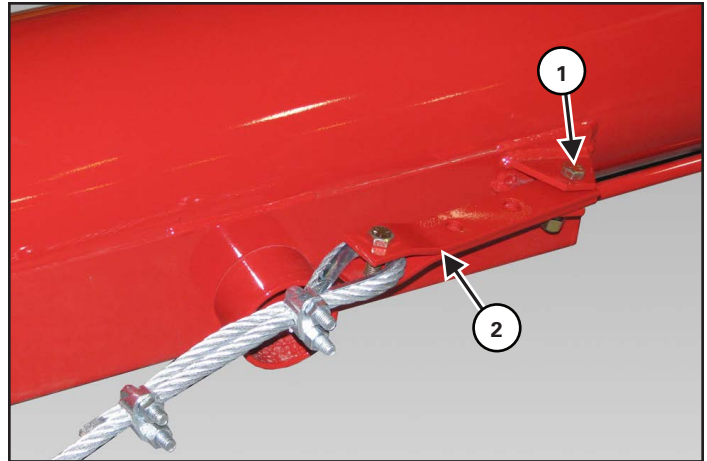

*Top Tube Adjustment Bracket*

Make sure the bottom adjustment bolts (Item 1) are loosened **[Figure 56]**.

Remove bolt (Item 1) and lock nut from the adjustment bracket (Item 2) **[Figure 57]**.

Move the bracket (Item 2) back, one hole. Re-install the bolt and lock nut. Tighten until the bracket is securely fastened to the tube mount **[Figure 57]**.

Repeat for adjusting remaining bridging cables.

Re-tighten the bottom adjustment bolts (Item 1) **[Figure 56]**.

## Side Cables - Model 16104

Figure 58

*Bottom Tube Adjustment Bolt*

Loosen all cable clamps along the cable being tightened.

Tighten the nut (Item 1) of the left / right bridging cable on tube #1 [Figure 58].

Tighten both left and right side bridging cables evenly.

Look down the length of the auger tubes.

If the tube bends left or right, loosen the adjustment bolt on one side while tightening the bolt on the opposite side until straight.

Snug the adjustment nut securely against the mount once adjustments are complete.

**IMPORTANT**

**If the nut is fully tightened and bottoms out against the eye of the adjustment bolt, the top tube adjustment bracket will need to be adjusted.**

**Do not remove the nut from the adjustment bolt.**

After adjusting the cable(s), tighten all cable clamps along the cable(s).

Figure 59

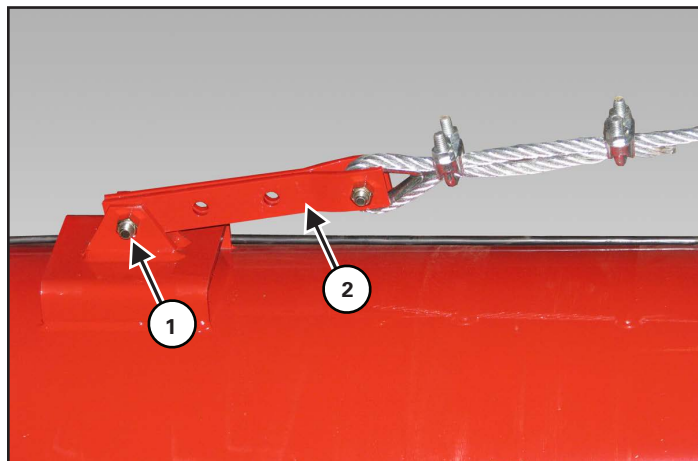
*Top Tube Adjustment Bracket*

Make sure the bottom adjustment bolt (Item 1) is loosened [Figure 58].

Remove bolt (Item 1) and lock nut from the adjustment bracket (Item 2) [Figure 59].

Move the bracket (Item 2) back, one hole. Re-install the bolt and lock nut. Tighten until the bracket is securely fastened to the tube mount [Figure 59].

Repeat for adjusting remaining bridging cables.

Re-tighten the bottom adjustment bolts (Item 1) [Figure 58].

## Trusses Inspection

Check trusses weekly or **EVERY 50 HOURS**:

**Figure 60**



Regularly check the truss beams, truss support brackets and all cross braces for cracks or damage. Repair or replace if damaged **[Figure 60]**.

Check and tighten any loose hardware.

## STORAGE AND RETURN TO SERVICE

### Storage

Sometimes it may be necessary to store the equipment for an extended period of time. Below is a list of items to perform before storage.



## IMPORTANT

**DO NOT permit children to play on or around the stored machine.**

- Thoroughly wash the machine with a pressure washer or water hose to remove all dirt, mud, debris or residue.
- Lubricate all bushings to remove any water residue from washing.
- Remove any material that has become entangled around any moving part.
- Inspect the hitch and all welds on the equipment for wear and damage.
- Check for loose hardware, missing guards, or damaged parts.
- Check for damaged or missing safety signs (decals). Replace if necessary.
- Replace worn or damaged parts.
- Touch up all paint nicks and scratches to prevent rusting.
- Place the equipment in a dry protected shelter.

**NOTE: If a dry protected shelter is not available, cover with a waterproof tarp and tie down securely.**

- Support the jack / frame with planks if required.

### Return To Service

After the equipment has been in storage, it is necessary to follow a list of items to return the equipment to service.

- Be sure all shields and guards are in place.
- Lubricate the equipment.
- Connect to a tractor and operate equipment, verify all functions operate correctly.
- Check for leaks. Repair as needed.

## SAFETY SIGN (DECAL) INSTALLATION



## IMPORTANT

**When replacing safety signs (decals), the temperature must be above 10° C (50° F).**

- Remove all portions of the damaged safety sign (decal).
- Thoroughly clean the area with adhesive remover and glass cleaner. Remove all adhesive residue.
- Allow the area to dry completely before installing the new safety sign (decal).
- Position the safety sign (decal) in the correct location.
- Remove a small portion of the backing paper on the safety sign (decal).
- Press on the safety sign (decal) where the backing paper has been removed.
- Slowly remove the remaining backing paper, pressing on the safety sign (decal) as the backing paper is removed.
- Using the backing paper, pressing firmly, move the backing paper over the entire safety sign (decal) area.

**NOTE: Small air pockets can be pierced with a pin and smoothed out using the piece of the backing paper.**

## ELECTRIC HOPPER CONTROL BOX TROUBLESHOOTING

Applies to all Units Equipped With Control Box SZ000997.



### IMPORTANT

Check that wires and connectors are properly installed.

Check wires for damage.

Unplug system when not in use.

### Hopper Will Not Move Left Or Right

Check that the circuit breaker (Item 1) is not deactivated. Push the button in to reset. This could be caused by defective motors or pinched wiring [Figure 61].

Check wiring for damage. Repair or replace damaged wiring.

Check that all motors are operating properly. Replace non-operational motor.

### Hopper Will Only Move In One Direction

Disconnect the control box from the motors. Use a volts ohm meter to check the voltage at the drive wheel output wires.

There should be system voltage when pressing the left / right button on the control box. If there is voltage in both directions, the motor may be at fault and will need to be replaced.

If there is voltage in only one direction but not in the other, this is most likely a control relay failure (Item 2) [Figure 61].

Use the wire colors to determine the relay at fault:

- Green wire leads to the move-right relay
- White wire leads to the move-left relay

Replace defective relay.

### Remote Control Functions Correctly But The Move-Left/Right Switches On The Box Do Not

Check the wires leading to the move-left and move-right switches (Item 3). Make sure the wires are connected properly [Figure 61].

Check wiring for damage. Repair or replace damaged wiring.

Figure 61

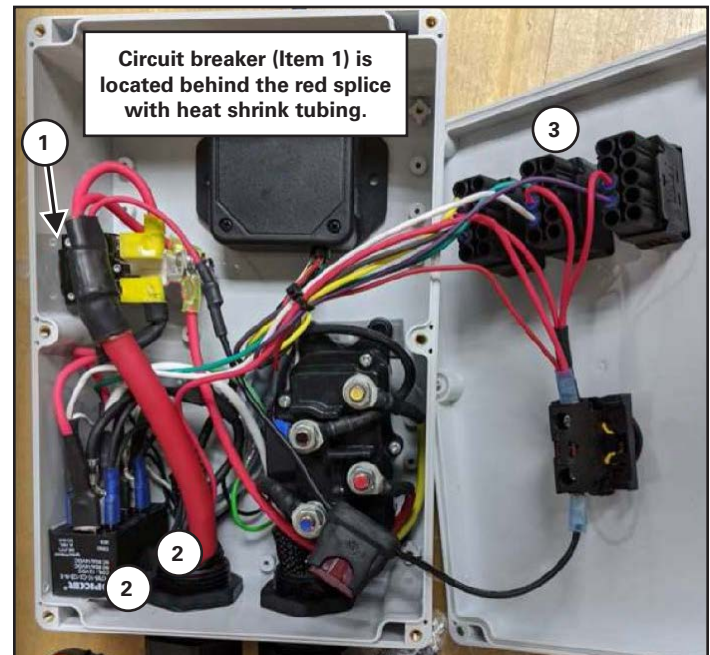

### Winch Will Not Raise Or Lower

Check that the circuit breaker (Item 1) is not deactivated. Push the button in to reset. This could be caused by defective motors or pinched wiring [Figure 62].

Check wiring for damage. Repair or replace damaged wiring.

Check that the winch motor is operating properly. Replace non-operational motor.

### Winch Will Only Rotate In One Direction

Disconnect the control box from the winch. Use a volts ohm meter to check the voltage at the winch output connection.

There should be system voltage when pressing the lift / lower button on the control box. If there is voltage in both directions, the motor may be at fault and will need to be replaced.

If there is voltage in only one direction but not in the other, this is most likely a control relay failure (Item 2) [Figure 62].

Use the wire colors to determine the relay at fault:

- Yellow wire leads to the winch-lower relay
- Brown wire leads to the winch-raise relay

Replace defective relay.

### Remote Control Functions Correctly But The Raise/Lower Switches On The Box Do Not

Check the wires leading to the move-raise and move-lower switches (Item 3). Make sure the wires are connected properly [Figure 62].

Check wiring for damage. Repair or replace damaged wiring.

Figure 62

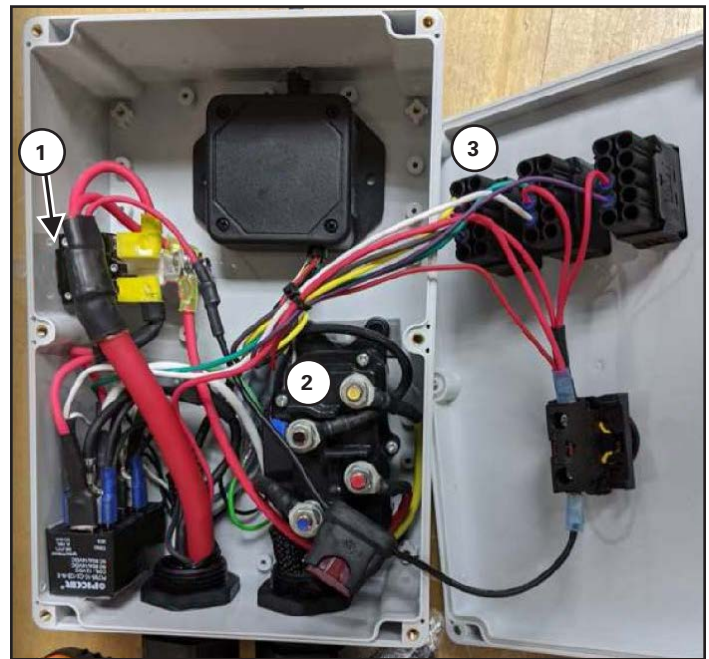

## ELECTRIC HOPPER REMOTE OPERATION

### Operation

Press and hold the power button on the transmitter until both LEDs turn on, then release.

The green LED will flash rapidly when communication has been established with the receiver. The green LED flashes slowly if the receiver is off or there is no communication between the transmitter and receiver.

Turn the receiver on and press the corresponding buttons on the transmitter keypad to turn on and off the LEFT, RIGHT, WINCH UP, WINCH DOWN outputs.

The only way to turn to turn off the LIGHT output early is to recycle power to the receiver with the transmitter off.

### Recharging

The red BATTERY LED on the transmitter will blink once every second when the battery is low and requires charging.

Plug the charging connector into the port at the top of the transmitter. Observe orientation and do not use force.

A solid red LED indicates battery is charging. Once the internal battery is fully charged, the red LED will turn off and the green LED will turn on. A fully discharged unit will take up to 3 hours to recharge. Use only approved chargers.

### Indicator Lights

The receiver has two LED indicators, the red ERROR CODE indicator and the green SIGNAL indicator.

The green SIGNAL indicator flashes rapidly whenever there is communication between the transmitter and the receiver.

The red ERROR CODE indicator starts blinking once every second when there is no RF communication between the receiver and transmitter. It also blinks when there is a problem with the system in the form of an error code. Refer to the ERROR CODE CHART table for more information.

Figure 63



### Teach ID Code

To synchronize a new transmitter and receiver together use the following procedure:

1. Make sure both transmitter and receiver are off.
2. Press and hold the POWER button until both lights start to blink to put the transmitter into TEACH ID mode.
3. Release the POWER button.
4. Apply power to receiver.
5. Wait for 1 second or until the green and red LEDs on the transmitter stop blinking and green LED start blinking rapidly.

## PART IDENTIFICATION - CONTROL BOX SZ000997

Figure 64



Figure 65



ITEM [Figure 64], [Figure 65]	PART NUMBER	DESCRIPTION	QTY.
1	931903	WIRE HARNESS	1
2	931904	30 AMP BREAKER	1
3	931905	70 AMP BREAKER	1
4	931906	60 AMP RELAY	2
5	931907	12V 160 AMP CONTACTOR	1
6	931908	2-POSITION SWITCH	1
7	931909	3-POSITION SWITCH	2
8	931910	LABEL	1
9	SZ001002	REMOTE	1
10	931911	RECEIVER	1
11	931912	E-STOP SWITCH	1

## PARTS IDENTIFICATION

GENERAL PARTS INFORMATION.....	73
INPUT BOX - 1684, 16104.....	74
INPUT BOX GEARBOX - 1684, 16104.....	76
INPUT BOX - 16124.....	78
INPUT BOX GEARBOX - 16124.....	80
UNDERCARRIAGE - 1684.....	82
UNDERCARRIAGE - 16104.....	84
UNDERCARRIAGE - 16124.....	86
BRIDGING - 1684.....	88
BRIDGING - 16104.....	90
BRIDGING - 16124.....	92
LIFT ARMS - 1684.....	96
LIFT ARMS - 16104.....	98
LIFT ARMS LOWER - 16124.....	100
LIFT ARMS UPPER - 16124.....	101
LIFT ARMS YOKE - 16124.....	102
LIFT ARMS CYLINDERS - 16124.....	103
TUBES - 1684.....	104
TUBES - 16104.....	106
TUBES - 16124.....	108
TUBE SECTIONS - 1684.....	110
TUBE SECTIONS - 16104.....	113
TUBE SECTIONS - 16124.....	116
HOPPER LIFT ARM - 1684, 16104.....	120
HOPPER LIFT ARM - 16124.....	121
INTAKE AUGER.....	122
INTAKE AUGER TUBE.....	124

HOPPER.....	126
HOPPER FLIGHTING.....	128
LIGHT KIT - 16124.....	130
HYDRAULIC HOPPER MOVER /WINCH - 1684, 16104.....	132
HYDRAULIC HOPPER MOVER /WINCH - 16124.....	136
ELECTRIC HOPPER MOVER /WINCH - 16124.....	140

## GENERAL PARTS INFORMATION

The parts identification section list descriptions, part numbers and quantities for all North America Base Model BS16 Series Augers. Contact your Farm King dealer for additional parts information.

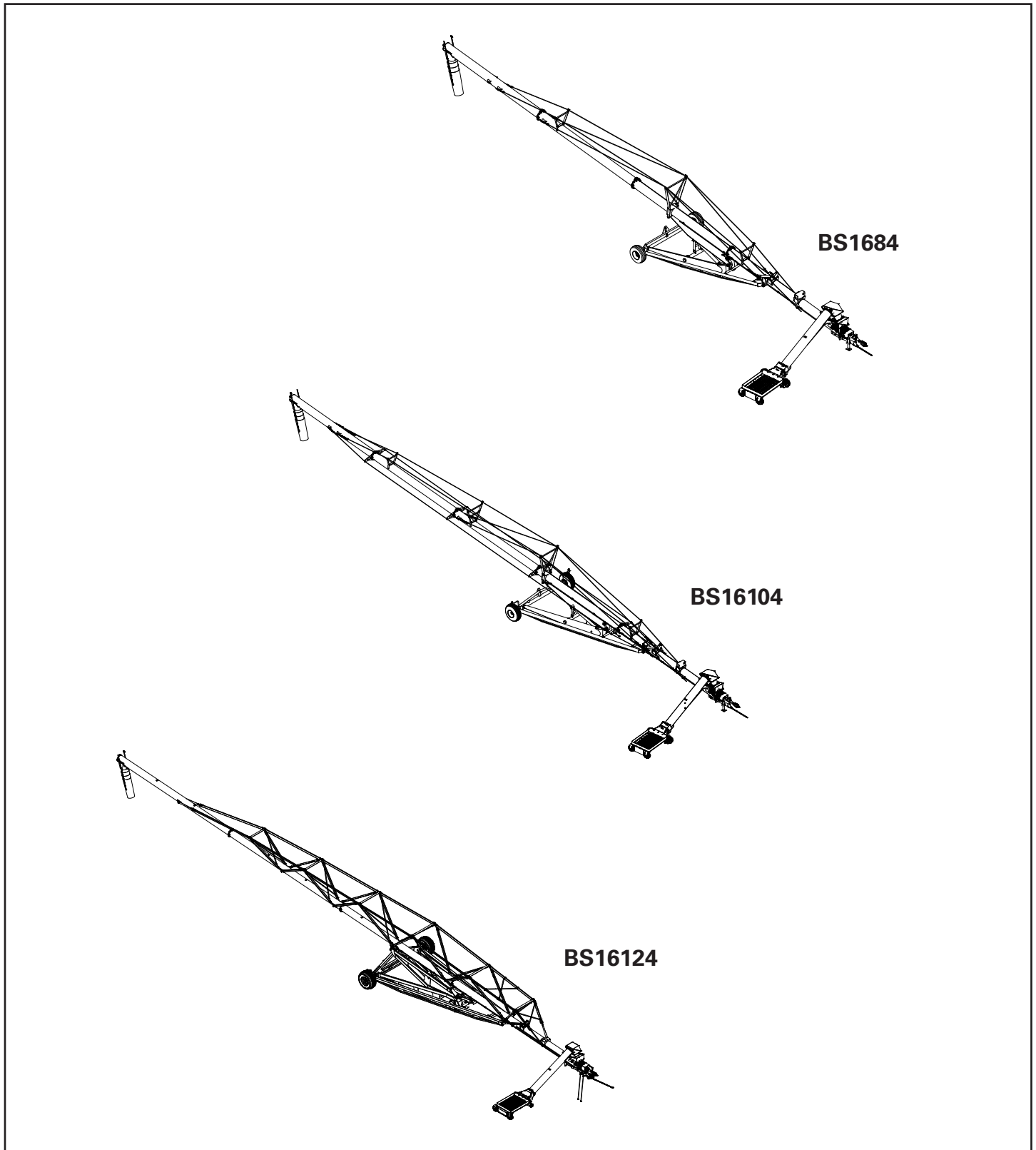

# INPUT BOX - 1684, 16104

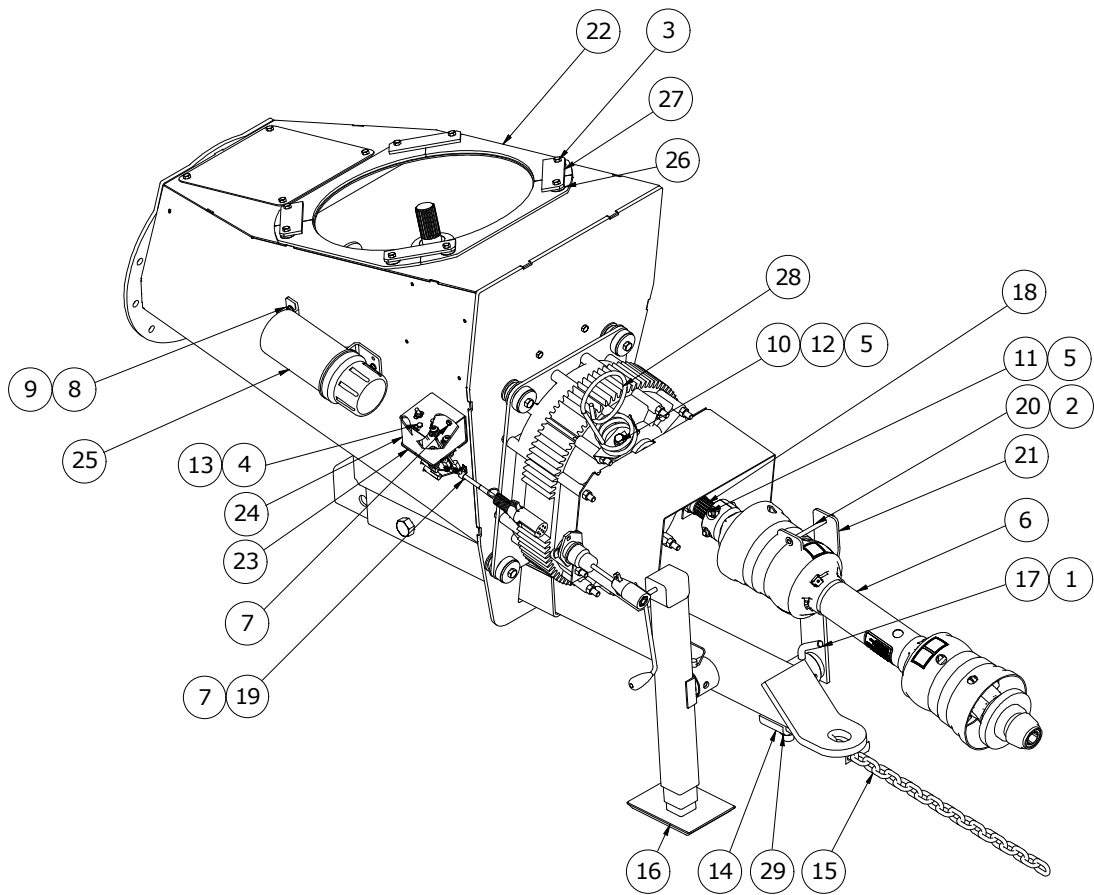
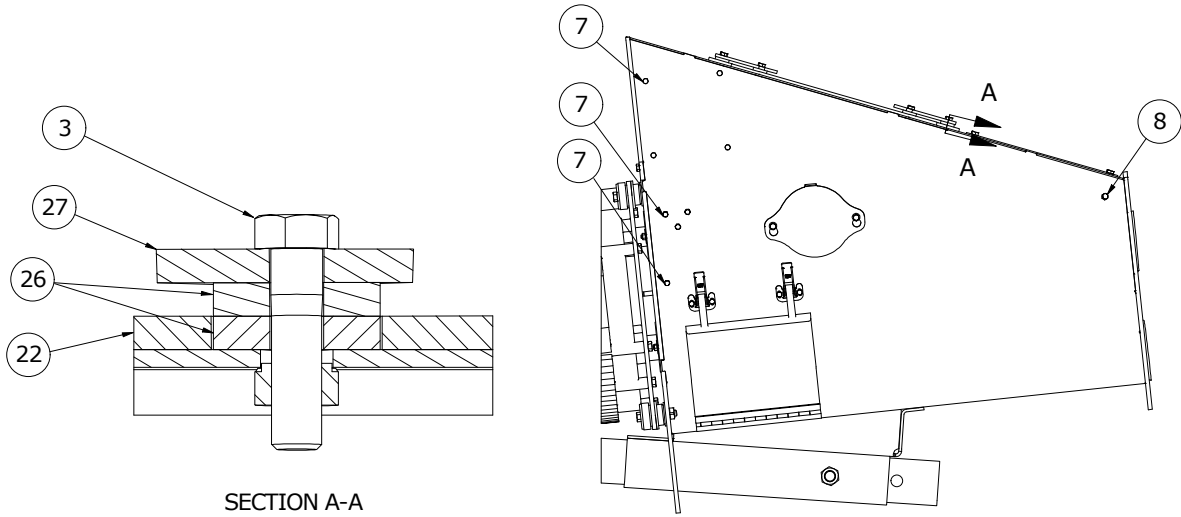

938948

ITEM	PART NUMBER	DESCRIPTION	QTY.
1	12779	#9 HAIR PIN CLIP (PL)	1
2	12780	#7 HAIR PIN CLIP	1
3	811792	3/8" X 1 1/2" HEX BOLT GR.5 (PL)	8
4	812025	BOLT HEX 0.250NC X 4.00GR5 PL	1
5	812364	1/2" LOCK NUT (PL)	3
6	F1814	PTO-1 3/8 X 21 CV - 1 3/4 X 20 CV	1
7	81525	1/4" X 3/4" HEX BOLT (PL)	12
8	81549	5/16" X 3/4" HEX BOLT (PL)	3
9	81569	5/16" LOCKWASHER PL	2
10	81620	1/2" X 1 1/4" HEX BOLT PL	1
11	81626	1/2" X 2 3/4" HEX BOLT (PL)	2
12	84048	1/2" SAE FLAT WASHER (PL)	1
13	84498	1/4" LOCK NUT (PL)	1
14	904580	SAFETY CHAIN PLATE	1
15	906284	HOOK & SAFETY CHAIN ASSEMBLY	1
16	909195	JACK	1
17	910288	LOCKING PIN	1
18	910503	M2000 SPLINED STUB SHAFT	1
19	912831	5/8" CABLE CLIP	1
20	913029	WELDMENT-CLEVIS PIN	1
21	914566	WELDT-PTO HOLDER	1
22	915902	SPACER-INTAKE	4
23	916910	BRKT-ELEC SWITCHES	1
24	916913	COVER-ELEC SWITCHES	1
25	935952	MANUAL HOLDER - 4.2" D	1
26	960494	1/4"W X 13/32"ID X 1 1/4"OD WASHER (PL)	16
27	960653	RING CLAMP PL	4
28	966314	HYDRAULIC HOSE HOLDER	1
29	967148	1" LOCK NUT (PL)	1

**INPUT BOX GEARBOX - 1684, 16104**

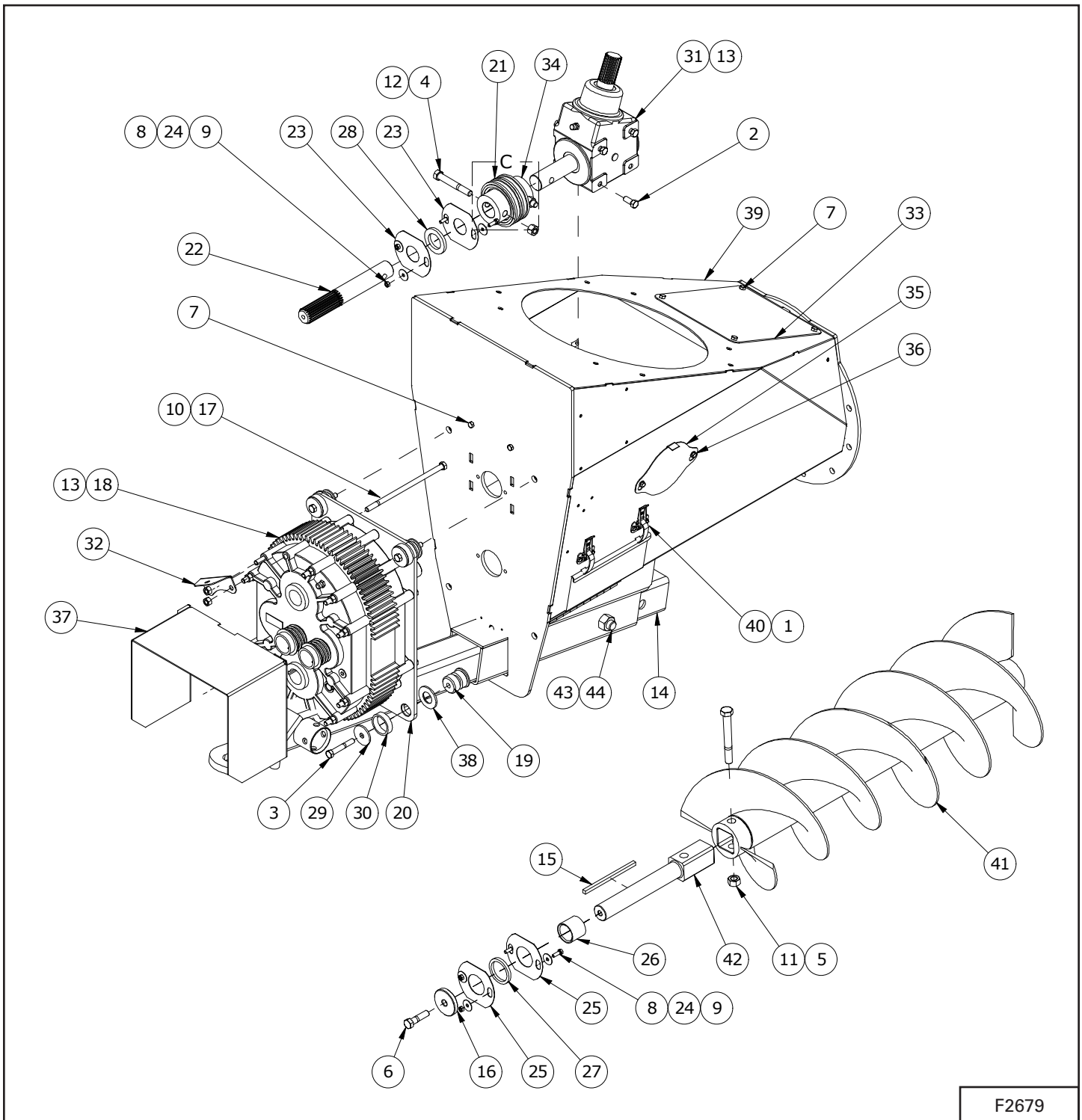

ITEM	PART NUMBER	DESCRIPTION	QTY.
1	81523	1/4" X 1/2" HEX BOLT (PL)	4
2	81620	1/2" X 1 1/4" HEX BOLT PL	6
3	81628	1/2" X 3 1/4" HEX BOLT (PL)	4

ITEM	PART NUMBER	DESCRIPTION	QTY.
4	81672	5/8" X 4 1/2" HEX BOLT (PL)	2
5	84215	3/4" X 6" HEX BOLT GR.5 (PL)	1
6	84335	5/8 X 2 1/2" HEX BOLT (PL)	1
7	86170	3/8" X 1" HEX BOLT GR.5 (PL)	6
8	812026	5/16" X 1" HEX BOLT (PL)	4
9	812362	5/16" LOCK NUT (PL)	4
10	812364	1/2" LOCK NUT (PL)	12
11	812365	3/4" LOCK NUT (PL)	1
12	812482	5/8" LOCK NUT (PL)	2
13	904578	GEAR OIL - SAE 75W-90 SYNTHETIC	3.95L
14	905887	HITCH WELDMENT	1
15	906061	INP BOX DR KEY 3/8" X 3/8" X 7 3/8"	1
16	906073	WASHER - INPUT BOX SHFT 21/32"ID X 3"OD X 1/2"	1
17	910458	1/2" X 11" HEX BOLT (PL)	12
18	910502	GEARBOX-M2000 HELICAL	1
19	914374	ISOLATOR-TWO PIECE, 240 LB MAX	4
20	914375	PLATE-M2000 GEARBOX MOUNT	1
21	914443	CHAIN-COUPLING DOUBLE 60H	1
22	914476	SHAFT-1.75 DIA 20 SPLINE	1
23	914523L	PLATE-INPUT BOX SEAL	2
24	914526	WASHER FLAT 1.25X0.313X0.05 PL	8
25	914543L	PLATE-INPUT BOX SEAL	2
26	916871	SPACER-INPUT BOX SHAFT	1
27	916880L	PLATE-INPUT SHAFT SEAL	1
28	916881L	PLATE-INPUT SHAFT SEAL	1
29	916914L	WASHER-ISOLATOR TOP	4
30	916922	TUBE-ISOLATOR LIMIT	4
31	916945	4168 GEARBOX-LOWER	1
32	916956	BRKT-HYD HOSE HOLDER	1
33	916995L	COVER-INPUT BOX	1
34	917026	SPROCKET-COUPLING 60H W/BORE	2
35	917446	COVER-GEARBOX ACCESS	1
36	917483	BOLT FL 0.313NC X 1.00 GR5 PL	2
37	917753	GUARD-PTO	1
38	917754	PLATE-ISOLATOR SPACER	4
39	919976	WELDT-INPUT BOX BS16	1
40	931901	LATCH-SLOTTED	2
41	938044	WELDT-BS16" INPUT FLIGHTING	1
42	938045	SHAFT-INPUT DRIVE 2.25"	1
43	967148	1" LOCK NUT (PL)	1
44	967229	1" X 6" HEX BOLT (PL)	1

**INPUT BOX - 16124**

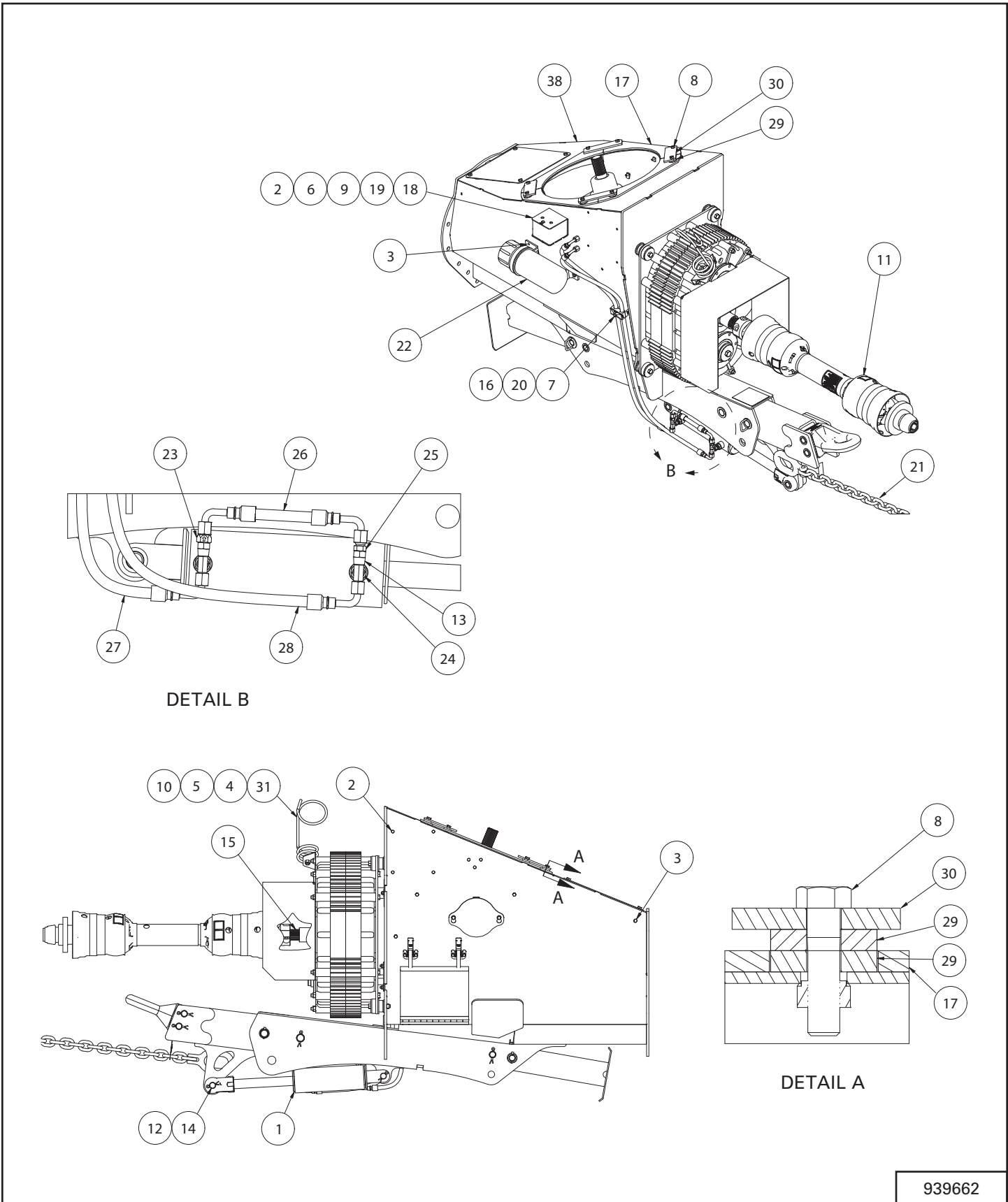

939662

ITEM	PART NUMBER	DESCRIPTION	QTY.
1	24803M	CYLINDER - 3.50 BORE X 8.00 STROKE	1
2	81525	1/4" X 3/4" HEX BOLT (PL)	10
3	81549	5/16" X 3/4" HEX BOLT (PL)	6
4	81620	1/2" X 1 1/4" HEX BOLT PL	1
5	84048	1/2" SAE FLAT WASHER (PL)	1
6	84498	1/4" LOCK NUT (PL)	1
7	810761	5/16" X 2 1/2" HEX BOLT (PL)	1
8	811792	3/8" X 1 1/2" HEX BOLT GR.5 (PL)	8
9	812025	BOLT HEX 0.250NC X 4.00GR5 PL	1
10	812364	1/2" LOCK NUT (PL)	1
11	F1813	PTO-1 3/8 X 21 CV - 1 3/4 X 20 CV	1
12	9812434	1/4" X 1 1/2" COTTER PIN (PL)	2
13	887572	TEE 9/16 MJIC X 9/16 SWFJIC	2
14	900705	PIN WELDMENT 1.000" DIA	2
15	910503	M2000 SPLINED STUB SHAFT	1
16	914640	HOSE CLAMP-TWIN 0.787 DIA	1
17	915902	SPACER-INTAKE	4
18	916910	BRKT-ELEC SWITCHES	1
19	916913	COVER-ELEC SWITCHES	1
20	917014	COVER-TWIN CLAMP 3D	1
21	930420	HOOK & SAFETY CHAIN ASSEMBLY	1
22	935952	MANUAL HOLDER - 4.2" D	1
23	939275	VALVE-CHECK -6 MJIC X -6 MJIC	1
24	939285	ADAPTER -8 MORB X -6 SFJIC	2
25	939679	ADAPTOR -6 MJIC X -6 MJIC	1
26	939680	HOSE -6 X -6 FJIC X -6 FJIC	1
27	939681	HOSE -6 X -6 FJIC X -6 FJIC	1
28	939682	HOSE -6 X -6 FJIC X -6 FJIC	1
29	960494	1/4"W X 13/32"ID X 1 1/4"OD WASHER (PL)	16
30	960653	RING CLAMP PL	4
31	966314	HYDRAULIC HOSE HOLDER	1

**INPUT BOX GEARBOX - 16124**

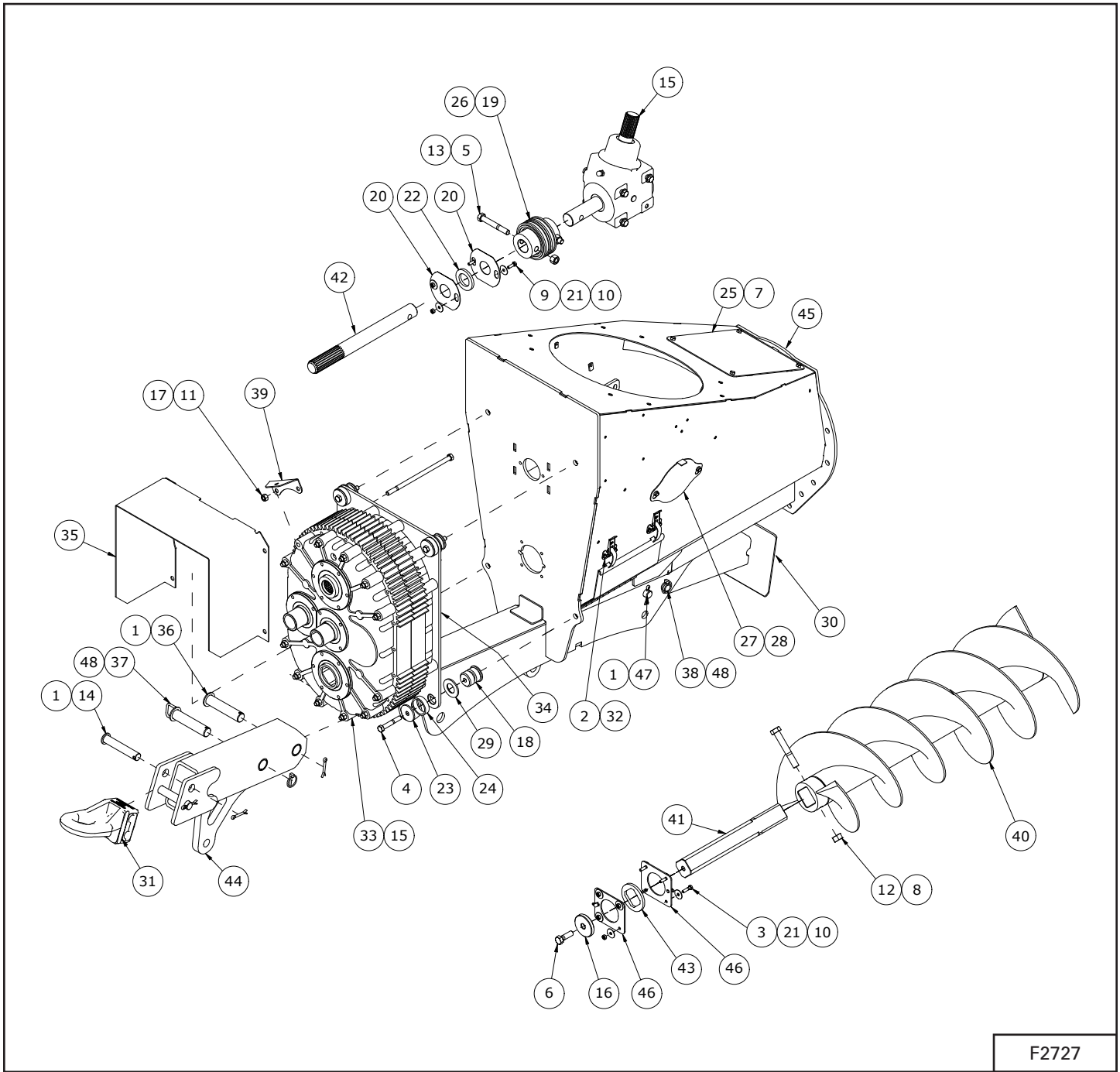

F2727

ITEM	PART NUMBER	DESCRIPTION	QTY.
1	81210	1/4" X 2" COTTER PIN (PL)	4
2	81523	1/4" X 1/2" HEX BOLT (PL)	4
3	81552	5/16" X 1 1/4" HEX BOLT (PL)	4
4	81628	1/2" X 3 1/4" HEX BOLT (PL)	4
5	81672	5/8" X 4 1/2" HEX BOLT (PL)	2
6	84299	5/8" X 2" HEX BOLT GR.5 (PL)	1
7	86170	3/8" X 1" HEX BOLT GR.5 (PL)	4

ITEM	PART NUMBER	DESCRIPTION	QTY.
8	811751	3/4" X 5" HEX BOLT (PL)	1
9	812026	5/16" X 1" HEX BOLT (PL)	2
10	812362	5/16" LOCK NUT (PL)	6
11	812364	1/2" LOCK NUT (PL)	12
12	812365	3/4" LOCK NUT (PL)	1
13	812482	5/8" LOCK NUT (PL)	2
14	901399	PIN WELDMENT 1.000" DIA	2
15	904578	GEAR OIL - SAE 75W-90 SYNTHETIC	10.75L
16	906073	WASHER - INPUT BOX SHFT 21/32"ID X 3"OD X 1/2"	1
17	910458	1/2" X 11" HEX BOLT (PL)	12
18	914374	ISOLATOR-TWO PIECE, 240 LB MAX	4
19	914443	CHAIN-COUPLING DOUBLE 60H	1
20	914523L	PLATE-INPUT BOX SEAL	2
21	914526	WASHER FLAT 1.25X0.313X0.05 PL	12
22	916881L	PLATE-INPUT SHAFT SEAL	1
23	916914L	WASHER-ISOLATOR TOP	4
24	916922	TUBE-ISOLATOR LIMIT	4
25	916995L	COVER-INPUT BOX	1
26	917026	SPROCKET-COUPLING 60H W/BORE	2
27	917446	COVER-GEARBOX ACCESS	1
28	917483	BOLT FL 0.313NC X 1.00 GR5 PL	2
29	917754	PLATE-ISOLATOR SPACER	4
30	931671	WELDT-AUGER STAND	1
31	931676	CAT. 3 PINTLE HITCH BASE	1
32	931901	LATCH-SLOTTED	2
33	937038	GEARBOX-BS16124	1
34	937161	PLATE- GEARBOX MOUNT	1
35	937165	BRKT-PTO GUARD	1
36	937520	WELDT-PIN 1.250" DIA	1
37	937522	WELDT- 1.250 DIA PIN W/ HANDLE	1
38	937524	WELDT-1.00 DIA PIN W/ HANDLE	1
39	937525	BRKT-HYD HOSE HOLDER	1
40	938044	WELDT-BS16" INPUT FLIGHTING	1
41	938228	SHAFT-INPUT DRIVE 2.25" BS16124	1
42	938233	SHAFT-1.75 DIA INPUT BOX TOP	1
43	939252L	PLATE-INPUT SHAFT SEAL	1
44	939328	WELDT-HITCH TUBE	1
45	939335	WELDT-INPUT BOX BS16	1
46	939348	ASSY- INPUT BOX SEAL	2
47	960631	LIFT ARM CLEVIS PIN WELDT 1.000" DIA	1
48	966729	3/16" LINCH PIN (PL)	2

# UNDERCARRIAGE - 1684

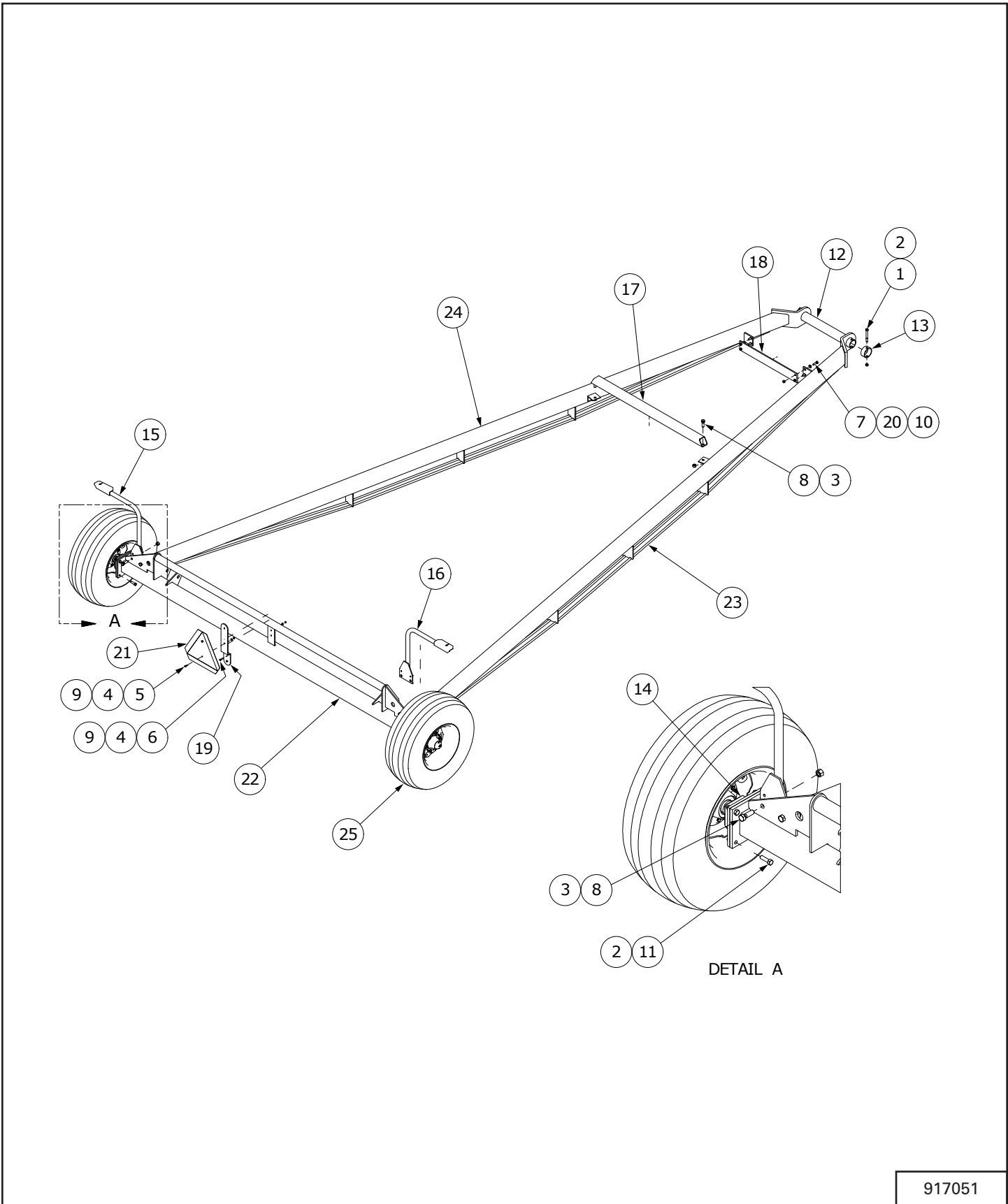

917051

ITEM	PART NUMBER	DESCRIPTION	QTY.
1	811691	1/2" X 4 1/2" HEX BOLT (PL)	2
2	812364	1/2" LOCK NUT (PL)	10
3	812482	5/8" LOCK NUT (PL)	14
4	812624	1/4" FLAT WASHER PL	4
5	81525	1/4" X 3/4" HEX BOLT (PL)	2
6	81527	1/4" X 1" HEX BOLT (PL)	2
7	81599	7/16" X 1 1/2" HEX BOLT (PL)	4
8	84299	5/8" X 2" HEX BOLT GR.5 (PL)	14
9	84498	1/4" LOCK NUT (PL)	4
10	86273	7/16" LOCK NUT (PL)	4
11	87553	1/2" X 1.75" HEX BOLT UNC GR5 (PL)	8
12	905735	UNDERCARRIAGE PIN	1
13	905736	UNDERCARR PIN SLEEVE 3 1/6"ID X 3 1/2"OD X 1 1/2"	2
14	906573	STUB AXLE ASSEMBLY	2
15	909226	BLINKER MOUNT WELDT - RH	1
16	909227	BLINKER MOUNT WELDMENT - LH	1
17	912793	LIFT ARM RESTTUBE	1
18	912794L	BRACE PLATE	1
19	934486	BRKT-SMV MOUNT	1
20	964001	1" X 7/16" X 10GA FLAT WASHER (PL)	4
21	967066	SLOW MOVING VEHICLE SIGN	1
22	F1460	WELDT- AXLETUBE	1
23	F1480	RIGHT UNDERCARRIAGE ARM	1
24	F1481	LEFT UNDERCARRIAGE ARM	1
25	F1808	12.5L-15FL (TL), IMPLEMENT TIRE & RIM MTD W VALVE	2

### UNDERCARRIAGE - 16104

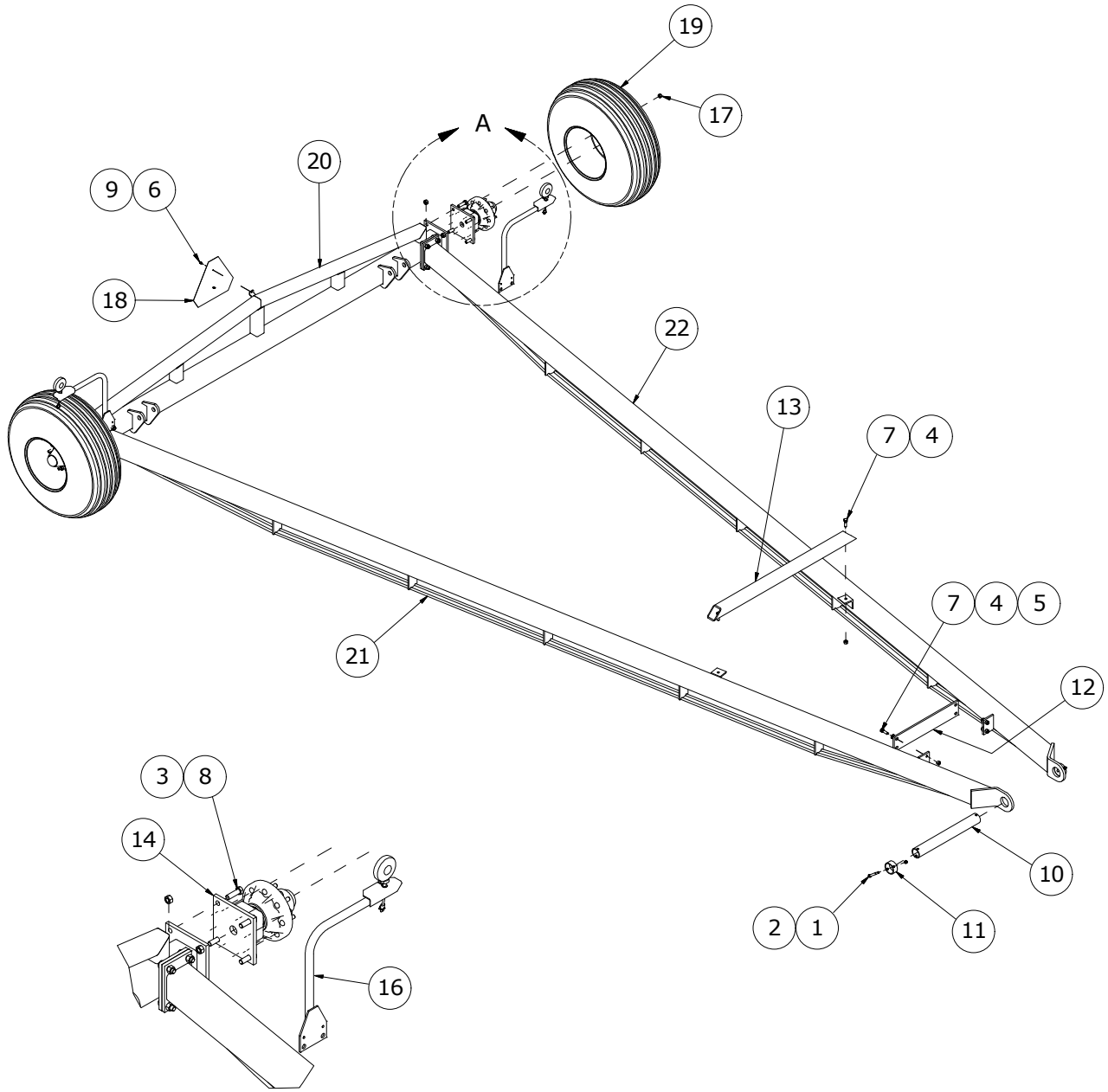

914809

ITEM	PART NUMBER	DESCRIPTION	QTY.
1	811691	1/2" X 4 1/2" HEX BOLT (PL)	2
2	812364	1/2" LOCK NUT (PL)	2
3	812365	3/4" LOCK NUT (PL)	16
4	812482	5/8" LOCK NUT (PL)	6
5	812639	WASHER 0.625 SAE FLAT BS PL	4
6	81523	1/4" X 1/2" HEX BOLT (PL)	2
7	84299	5/8" X 2" HEX BOLT GR.5 (PL)	6
8	84346	3/4" X 2 1/2" HEX BOLT (PL)	16
9	84498	1/4" LOCK NUT (PL)	2
10	905735	UNDERCARRIAGE PIN	1
11	905736	UNDERCARR PIN SLEEVE 3 1/6"ID X 3 1/2"OD X 1 1/2"	2
12	905737L	BRACE PL 1/2" X 5" X 25 3/4"	1
13	905738	LIFT ARM REST 1/4"W X 3" X 3" X 57 1/2"	1
14	909191	ASSY-STUB SHAFT AND HUB BS16104	2
15	909226	BLINKER MOUNT WELDT - RH	1
16	909227	BLINKER MOUNT WELDMENT - LH	1
17	909779	5/8" NF WHEEL NUT	16
18	967066	SLOW MOVING VEHICLE SIGN	1
19	F0679	ASSY-UNDERCARRIAGE BS16104	2
20	F2316	AXLE WELDMENT (16" BS)	1
21	F2317	UNDERCARR. ARM WELDT - RIGHT	1
22	F2318	UNDERCARR. ARM WELDT - LEFT	1

### UNDERCARRIAGE - 16124

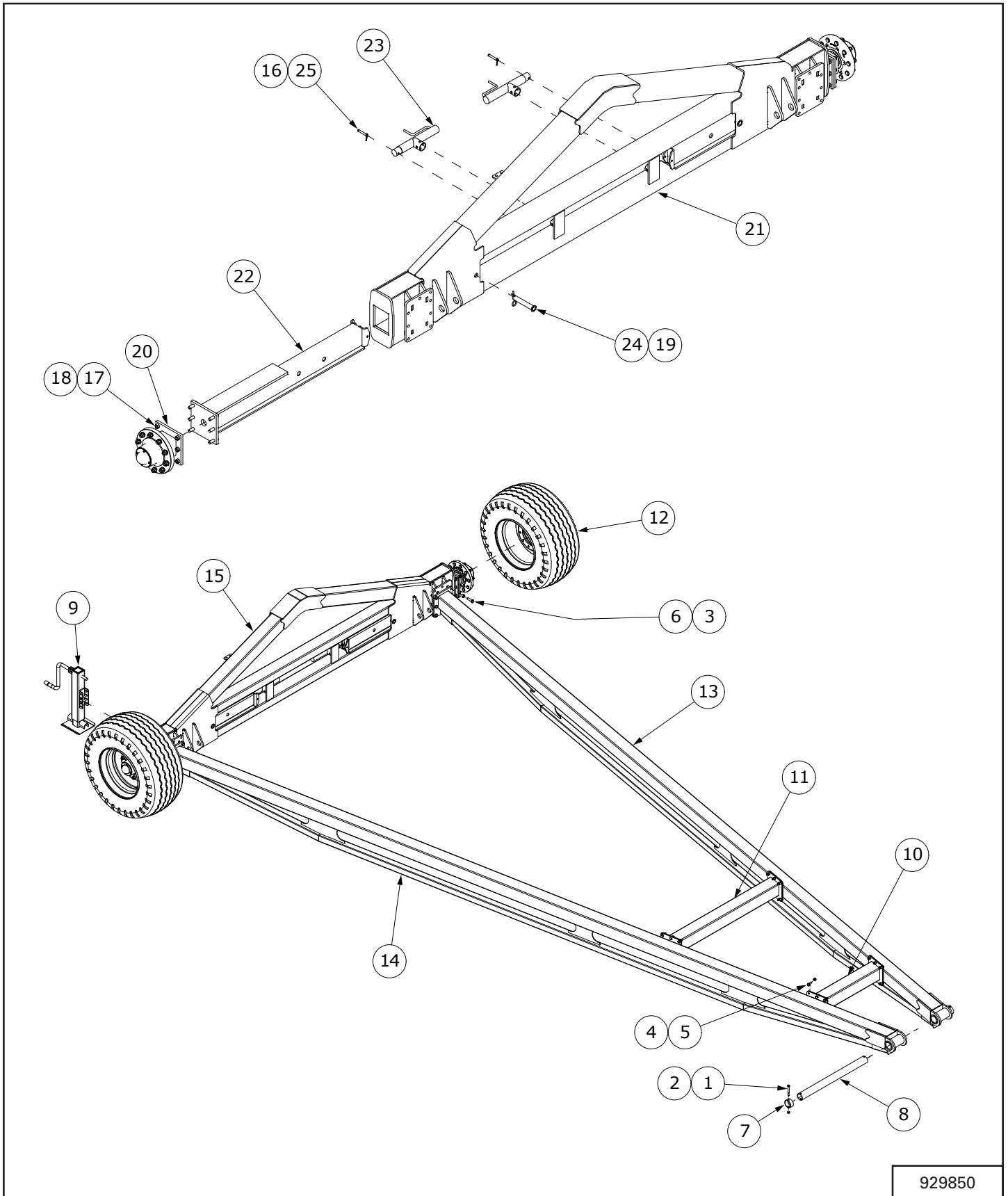

929850

ITEM	PART NUMBER	DESCRIPTION	QTY.
1	811691	1/2" X 4 1/2" HEX BOLT (PL)	2
2	812364	1/2" LOCK NUT (PL)	2
3	812365	3/4" LOCK NUT (PL)	12
4	812482	5/8" LOCK NUT (PL)	24
5	84268	5/8" X 1 1/2" HEX BOLT (PL)	24
6	84346	3/4" X 2 1/2" HEX BOLT (PL)	12
7	905736	UNDERCARR PIN SLEEVE 3 1/6"ID X 3 1/2"OD X 1 1/2"	2
8	926604	TUBE-UNDERCARRIAGE PIN	1
9	926683	JACK-SIDE WIND W/DROP LEG	1
10	930276	WELDT-CROSSBRACE	1
11	931422	WELDT-CROSSBRACE	1
12	F2145	TIRE AND WHEEL-FS24 480/55R22.5	2
13	F2299	WELDT-LH UNDERCARRIAGE ARM	1
14	F2300	WELDT-RH UNDERCARRIAGE ARM	1
15	F2322	ASSY-16124 AXLE	1
16	12780	#7 HAIR PIN CLIP	2
17	812365	3/4" LOCK NUT (PL)	12
18	84346	3/4" X 2 1/2" HEX BOLT (PL)	12
19	926917	1/4 HAIR PIN CLIP (PL)	2
20	930233	ASSY-OUTER EXT. AXLE	2
21	931457	WELDT-BS16124 AXLE	1
22	931480	WELDT-INNER EXTENSION AXLE	2
23	931535	JACK-2000 LB	2
24	960113	CYLINDER PIN WELDT 1.250" DIA	2
25	961011	01/2" X 3 1/2" CLEVIS PIN (PL)	2

# BRIDGING - 1684

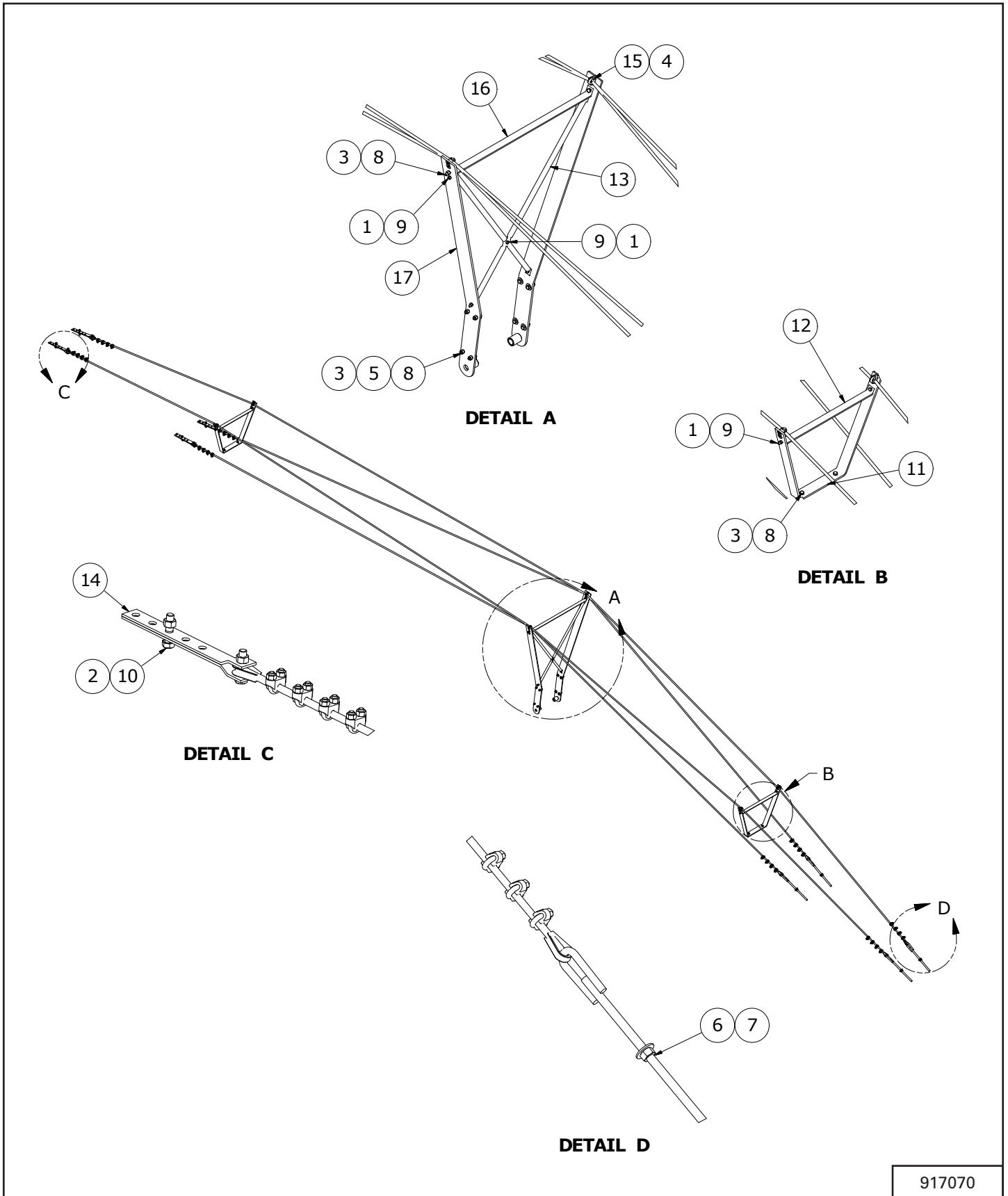

917070

ITEM	PART NUMBER	DESCRIPTION	QTY.
1	812364	1/2" LOCK NUT (PL)	9
2	812365	3/4" LOCK NUT (PL)	8
3	812482	5/8" LOCK NUT (PL)	14
4	81638	1/2" BS FLAT WASHER (PL)	12
5	81678	11/16" FLAT WASHER STD (PL)	8
6	81722	7/8 HEX NUT (PL)	4
7	81972	7/8" SAE WASHER	4
8	84299	5/8" X 2" HEX BOLT GR.5 (PL)	14
9	87553	1/2" X 1.75" HEX BOLT UNC GR5 (PL)	9
10	88742	3/4" X 3" HEX BOLT GR.5 (PL)	8
11	905816	BRIDGING YOKE PLATE	2
12	905817	BRIDGING BRACE PL	2
13	905827	BRIDGING BRACE	2
14	905853	CABLE YOKE PLATE	8
15	909194	3/4" CABLE CLAMP (PL)	6
16	909783	BRIDGING CROSS BRACE 3/8" X 2" X 53 1/4"	1
17	912797	BRIDGING PLATE WELDMENT	2
18	912840	UPPER CABLE ASSEMBLY	2
19	912841	LOWER CABLE ASSEMBLY	2

### BRIDGING - 16104

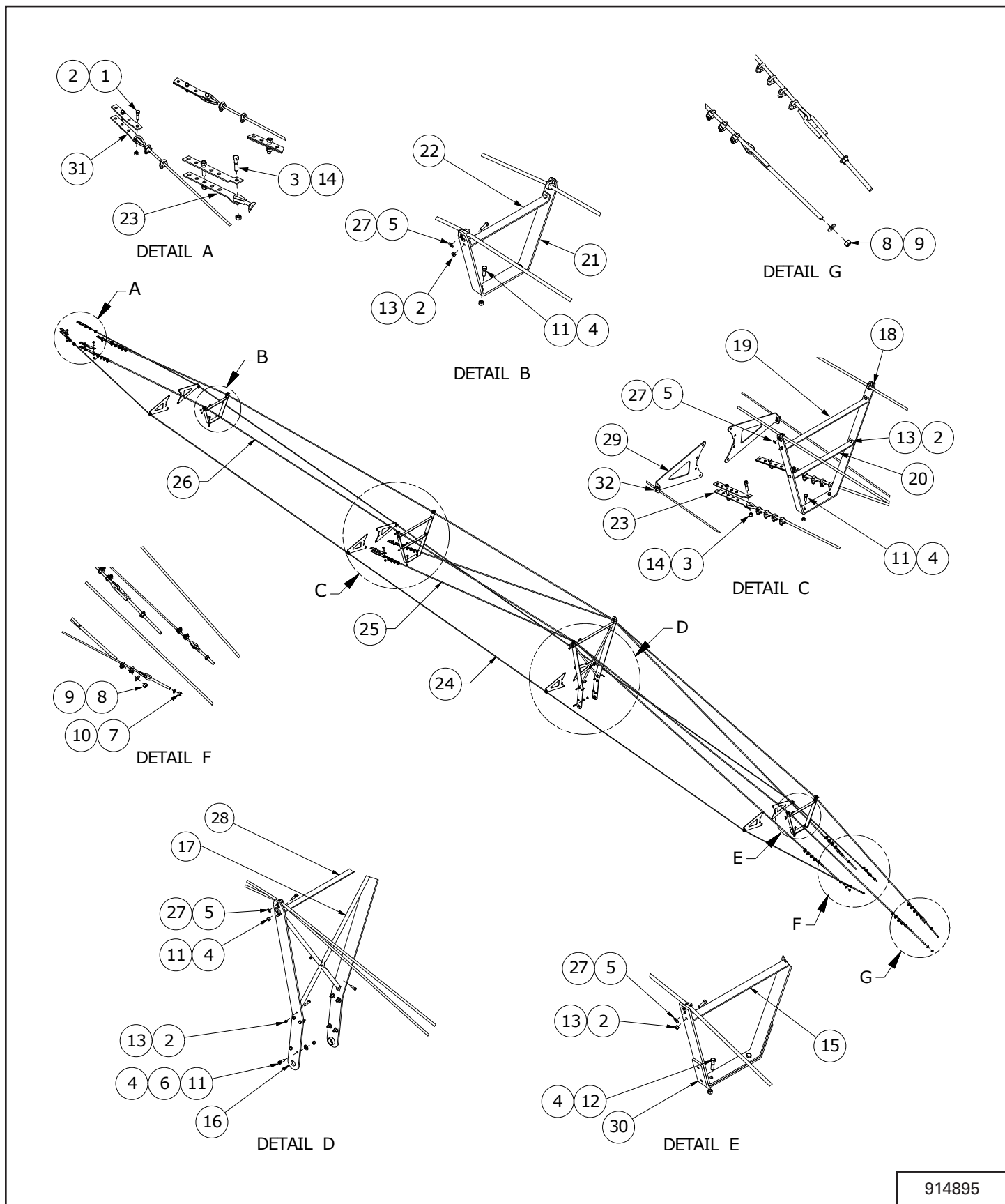

914895

ITEM	PART NUMBER	DESCRIPTION	QTY.
1	811791	1/2" X 2" HEX BOLT (PL)	4
2	812364	1/2" LOCK NUT (PL)	17
3	812365	3/4" LOCK NUT (PL)	8
4	812482	5/8" LOCK NUT (PL)	16
5	81638	1/2" BS FLAT WASHER (PL)	16
6	81678	5/8" FLAT WASHER STD (PL)	8
7	81700	3/4" HEX NUT (PL)	2
8	81722	7/8 HEX NUT (PL)	4
9	81972	7/8" SAE WASHER	4
10	84050	3/4" S.A.E. FLAT WASHER (PL)	2
11	84299	5/8" X 2" HEX BOLT GR.5 (PL)	14
12	84335	5/8 X 2 1/2" HEX BOLT (PL)	2
13	87553	1/2" X 1.75" HEX BOLT UNC GR5 (PL)	13
14	88742	3/4" X 3" HEX BOLT GR.5 (PL)	8
15	905817	BRIDGING BRACE PL	1
16	905826	BRIDGING PL WELDT - TUBE #2	2
17	905827	BRIDGING BRACE	2
18	905828	BRIDGING PL - TUBE #3 (1/2" X 3" X 103")	1
19	905829	BRIDGING BRACE - TUBE #3 (3/8" X 2" X 43")	1
20	905830	BRIDGING BRACE - TUBE #3	1
21	905831	BRIDGING PLATE - TUBE #4	1
22	905832	BRIDGING BRACE - TUBE #4	1
23	905853	CABLE YOKE PLATE	8
24	906045	ASSY-SIDE BRIDGING CABLE BS16104	2
25	906057	ASSY-LOWER BRIDGING CABLE BS16104	2
26	906059	ASSY-UPPER BRIDGING CABLE BS16104	2
27	909194	3/4" CABLE CLAMP (PL)	8
28	909783	BRIDGING CROSS BRACE 3/8" X 2" X 53 1/4"	1
29	914769	BRKT-SIDE BRIDGING	8
30	917934	WELDT-LOWER BRIDGING YOKE	1
31	960244	CABLE YOKE	4
32	964565	1/2" CABLE CLAMP (PL)	8

# BRIDGING - 16124

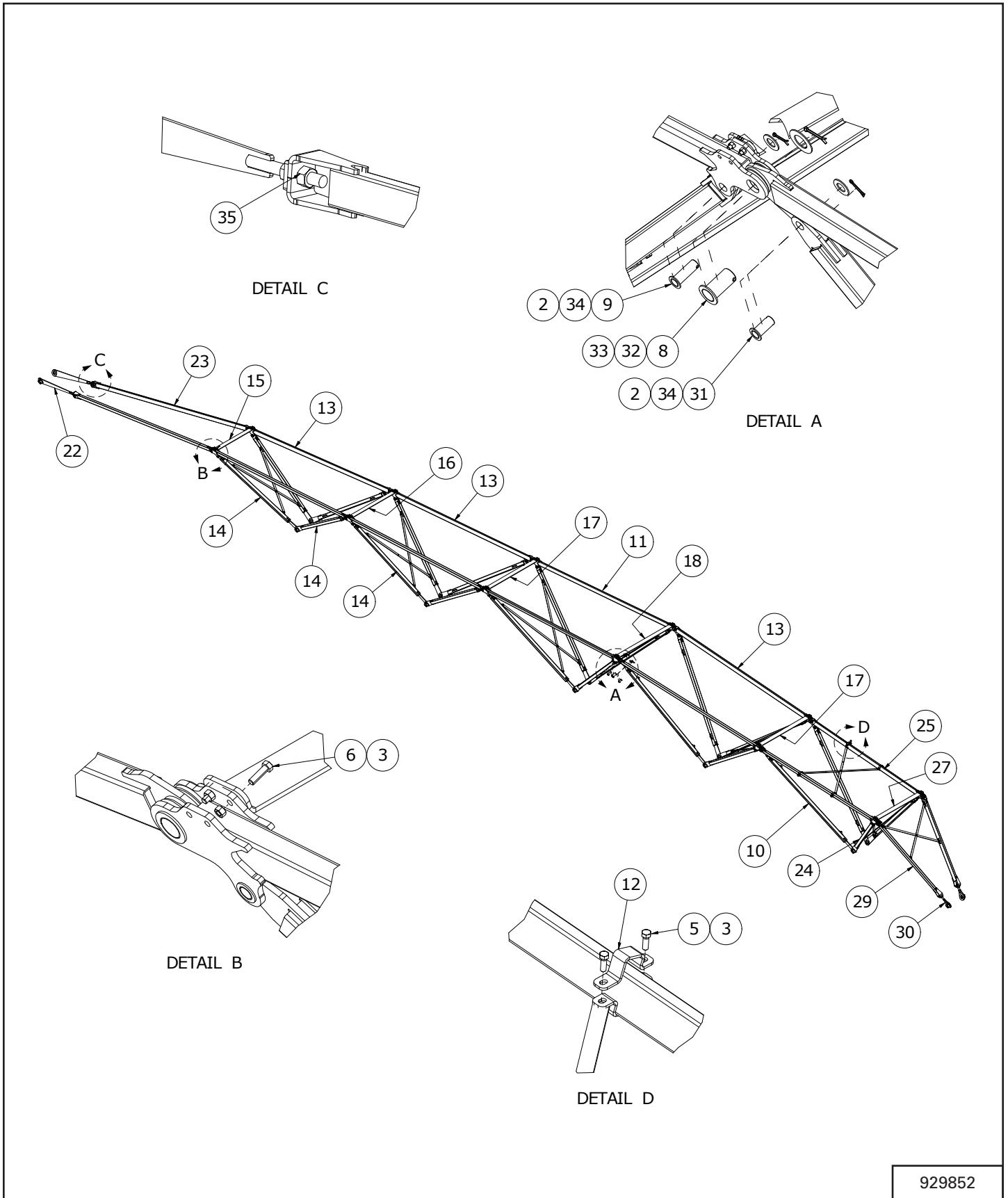

929852



ITEM	PART NUMBER	DESCRIPTION	QTY.
1	811691	1/2" X 4 1/2" HEX BOLT (PL)	14
2	81210	1/4" X 2" COTTER PIN (PL)	20
3	812364	1/2" LOCK NUT (PL)	82
4	84048	1/2" SAE FLAT WASHER (PL)	6
5	84277	1/2" X 1 1/2" HEX BOLT (PL)	44
6	87553	1/2" X 1.75" HEX BOLT UNC GR5 (PL)	24
7	905736	UNDERCARR PIN SLEEVE 3 1/6"ID X 3 1/2"OD X 1 1/2"	14
8	927850	WELDT-TRUSS PIN	12
9	927852	WELDT-TRUSS PIN	12
10	928096	WELDT-TRUSS BEAM	12
11	929131	WELDT-TRUSS BEAM	2
12	929746	BRKT - CROSS BRACE HOLDER	8
13	929861	WELDT-TRUSS BEAM	6
14	929866	WELDT-TRUSS BEAM	6
15	930056	BRKT-TRUSS SUPPORT	1
16	930065	BRKT-TRUSS SUPPORT	1
17	930066	BRKT-TRUSS SUPPORT	2
18	930067	BRKT-TRUSS SUPPORT	1
19	930068L	PLATE-CROSS BRACE	6
20	930069L	PLATE-CROSS BRACE	4
21	930074L	PLATE-CROSS BRACE	2
22	930625	WELDT-TRUSS FASTENER	2
23	930641	WELDT-TRUSS BEAM	2
24	931492	WELDT-TRUSS BEAM	2
25	931494	WELDT-TRUSS BEAM	2
26	931496L	PLATE-CROSS BRACE	2
27	931531	BRKT-TRUSS SUPPORT	1
28	932949L	PLATE-CROSS BRACE	2
29	935333	WELDT-TRUSS BEAM	2
30	935334	WELDT-TRUSS FASTENER	2
31	960108	LIFT ARM CLEVIS PIN WELDT 1.250" DIA	8
32	967153	2" X 10GA NARROW RIM WASHER (PL)	12
33	967162	5/16" X 3" COTTER PIN (PL)	12
34	9812487	1 1/4" X 10GA NARROW RIM WASHER (PL)	20
35	EZBN125	NUT HEX 1-1/4 NC GR2 ZNCR	8

# Farm King



# LIFT ARMS - 1684

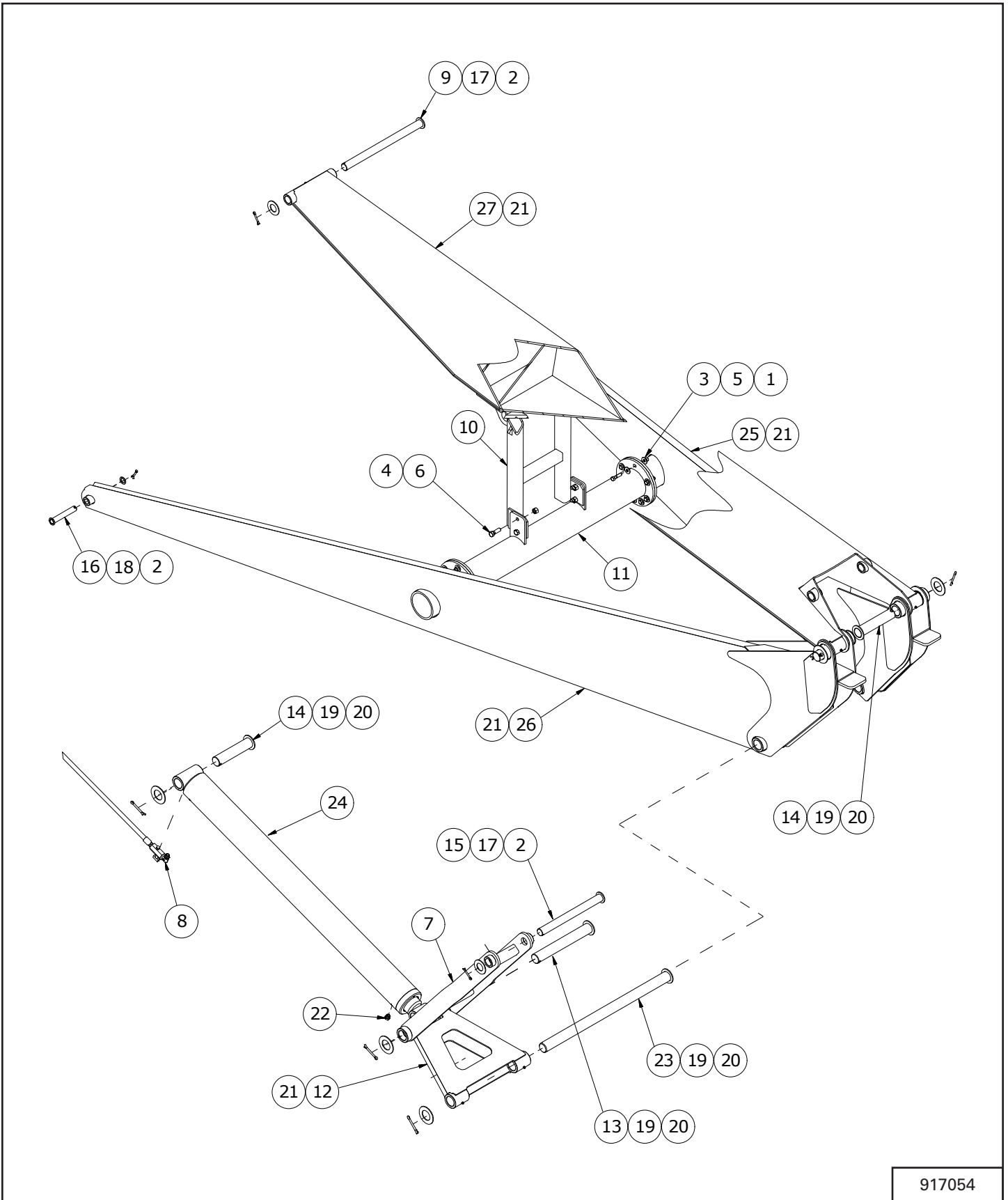

917054

ITEM	PART NUMBER	DESCRIPTION	QTY.
1	811791	1/2" X 2" HEX BOLT (PL)	16
2	81210	1/4" X 2" COTTER PIN (PL)	4
3	812364	1/2" LOCK NUT (PL)	16
4	812482	5/8" LOCK NUT (PL)	4
5	81638	1/2" BS FLAT WASHER (PL)	32
6	84299	5/8" X 2" HEX BOLT GR.5 (PL)	4
7	907342	YOKE WELDT	1
8	912751	HYDRAULIC ROUTING	1
9	912800	TOPYOKE PIN WELDT 1.500" DIA	1
10	913053	ASSY-UPPER LIFT ARM CRADLE	1
11	914956	LIFT ARM TORQUE TUBE WELDMENT	1
12	960688	LINK WELDMENT	1
13	960690	BOTTOM CYL PIN WELDT 2.000" DIA	1
14	960692	TOP CYLINDER PIN WELDT 2.000" DIA	3
15	960694	WELDMENT-TOPYOKE PIN 1.500" DIA	1
16	960695	LIFT ARM CLEVIS PIN 1.000" DIA	2
17	967135	1 1/2" RIM WASHER (10GA) (PL)	2
18	967140	1" X 10GA NARROW RIM WASH (PL)	2
19	967153	2" X 10GA NARROW RIM WASHER (PL)	5
20	967162	5/16" X 3" COTTER PIN (PL)	5
21	967164	DRIVE-IN GREASE ZERK	9
22	967908	PLUG-8 ORB VENT	1
23	F0035	CONNECTING LINK PIN WELDT 2.000" DIA	1
24	F0445M	CYLINDER-5.0X51.35	1
25	F1769	LOWER LIFT ARM - LEFT HAND	1
26	F1770	LOWER LIFT ARM - RIGHT HAND	1
27	F1943	WELDT-UPPER LIFT ARM	1

### LIFT ARMS - 16104

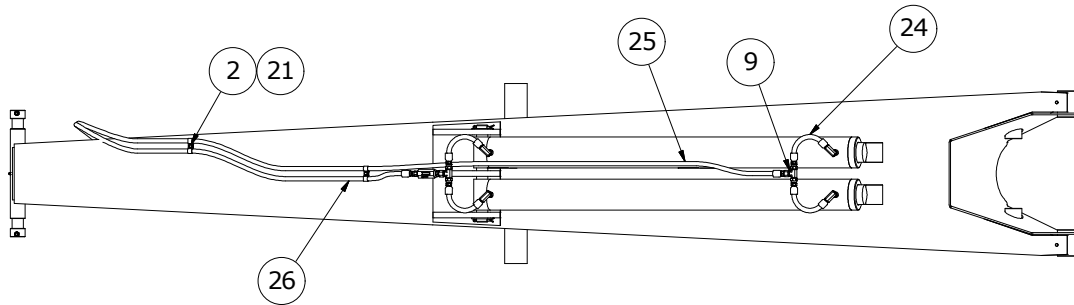

**UNDERSIDE OF UPPER LIFT ARM**

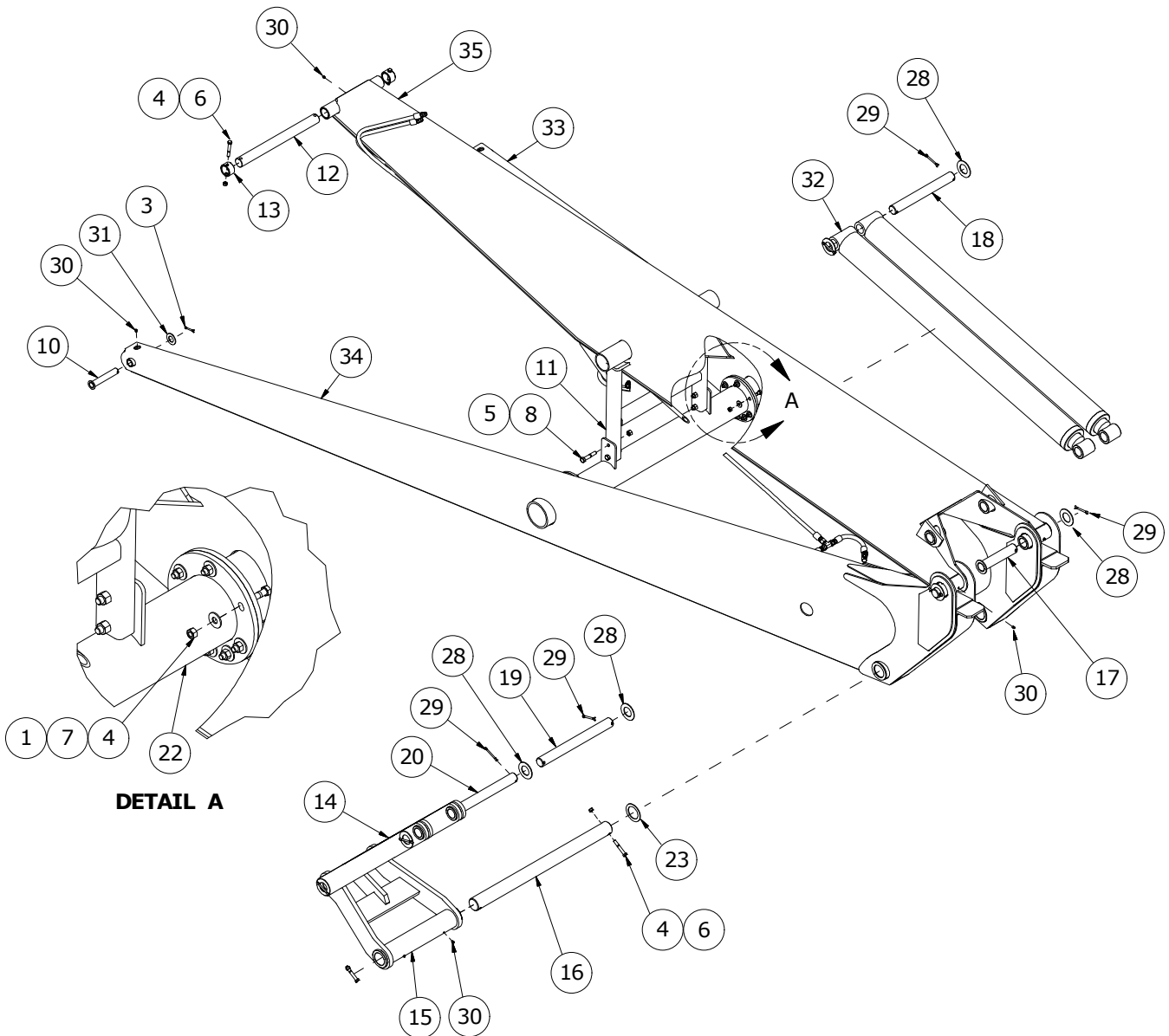

**DETAIL A**

914883

ITEM	PART NUMBER	DESCRIPTION	QTY.
1	811791	1/2" X 2" HEX BOLT (PL)	16
2	812026	5/16" X 1" HEX BOLT (PL)	2
3	81210	1/4" X 2" COTTER PIN (PL)	2
4	812364	1/2" LOCK NUT (PL)	20
5	812482	5/8" LOCK NUT (PL)	4
6	81629	1/2" X 3 1/2" HEX BOLT (PL)	4
7	81638	1/2" BS FLAT WASHER (PL)	32
8	81669	5/8" X 3 1/2" HEX BOLT (PL)	4
9	865341	TEE-10MJIC X -10MJIC X -10 FJIC	1
10	905779	AXLE PIN WELDT 1.250" DIA	2
11	905786	CRADLE REST WELDMENT (16" BS)	1
12	905806	UPPR LIFT ARM PIN	1
13	905807	UPPER LIFT ARM PIN COLLAR	2
14	908464	YOKE ARM WELDMENT (16104 BS)	2
15	908472	16" LINK WELDMENT	1
16	908474	PIN-CONNECTING YOKE 2.750" DIA	1
17	908476	LIFT ARM PIN WELDT 2.000" DIA	2
18	908478	CYL PIN ROD 2.000" DIA	1
19	908480	UPPER LIFT ARM PIN 2.000" DIA	1
20	908490	LIFT PIN ROD 2.000" DIA	1
21	913193	P-CLIP 0.75	4
22	914760	LIFT ARM TORQUE TUBE WELDT (1305mm LG)	1
23	930470L	2 3/4" X 10GA NARROW RIM WASHER	2
24	930540	HOSE-8 X -8MORB 90 X -10JIC	4
25	930976	HOSE-8 X -10MJIC X -10MJIC	1
26	930977	ASSY-HYDRAULIC ROUTING	1
27	967103	TIE 30"	2
28	967153	2" X 10GA NARROW RIM WASHER (PL)	8
29	967162	5/16" X 3" COTTER PIN (PL)	8
30	967164	DRIVE-IN GREASE ZERK	7
31	9812487	1 1/4" X 10GA NARROW RIM WASHER (PL)	2
32	F0664M	CYLINDER 5.00 X 55.35 3/4 ORB	2
33	F1767	LOWER LIFT ARM WELDT - LEFT	1
34	F1768	LOWER LIFT ARM WELDT - RIGHT	1
35	F2315	UPPER LIFT ARM WELDMENT (16104)	1

**LIFT ARMS LOWER - 16124**

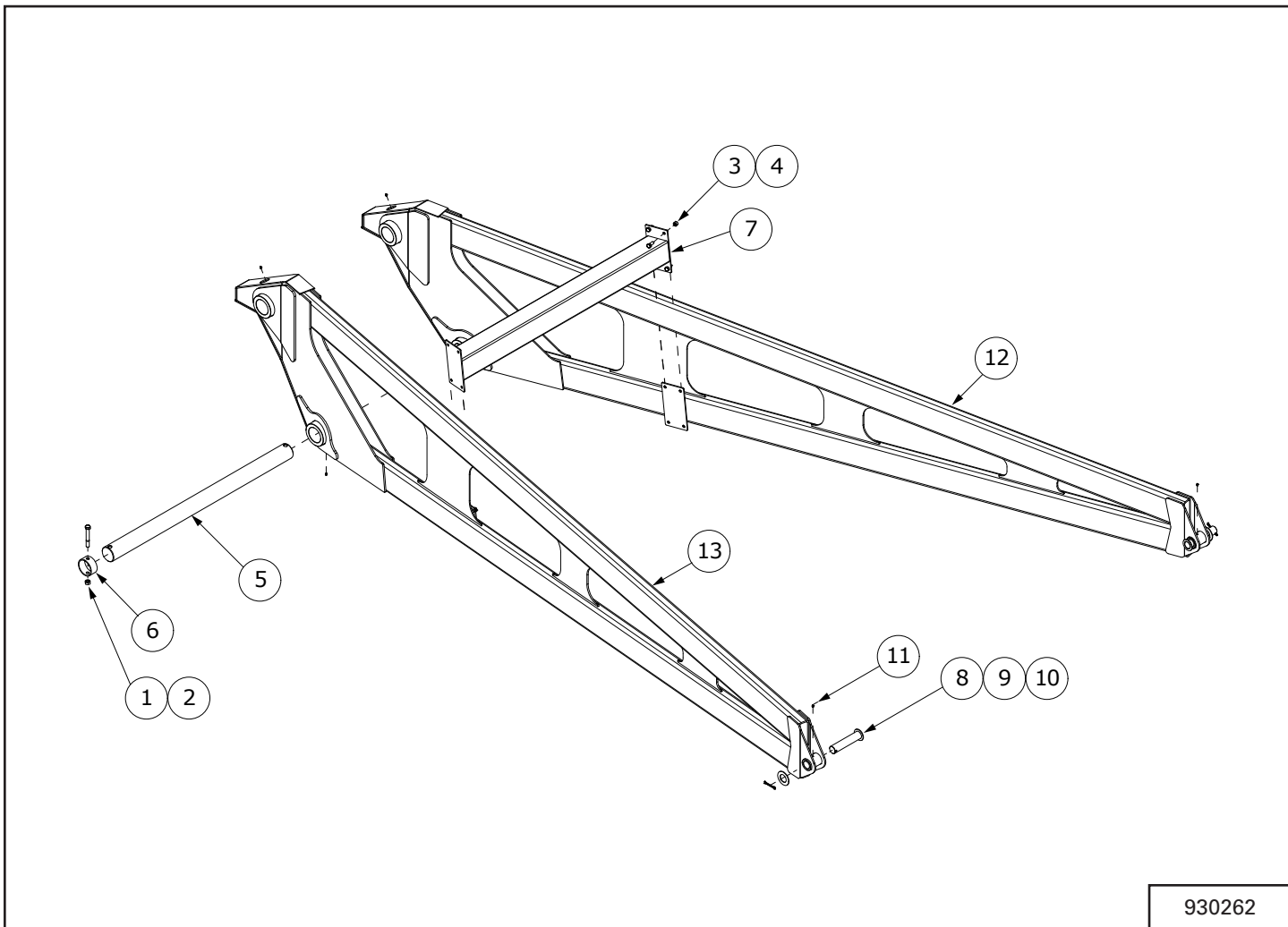

ITEM	PART NUMBER	DESCRIPTION	QTY.
1	812114	3/4" X 5 1/2" HEX BOLT (PL)	2
2	812365	3/4" LOCK NUT (PL)	2
3	812482	5/8" LOCK NUT (PL)	8
4	84268	5/8" X 1 1/2" HEX BOLT (PL)	8
5	929943	PIN-4.000" DIA	1
6	930113	TUBE-PIN SLEEVE	2
7	930267	WELDT-SUPPORT BRACE	1
8	960692	TOP CYLINDER PIN WELDT 2.000" DIA	2
9	967153	2" X 10GA NARROW RIM WASHER (PL)	2
10	967162	5/16" X 3" COTTER PIN (PL)	2
11	967164	DRIVE-IN GREASE ZERK	6
12	F2287	WELDT-RH LOWER LIFT ARM	1
13	F2288	WELDT-LH LOWER LIFT ARM	1

**LIFT ARMS UPPER - 16124**

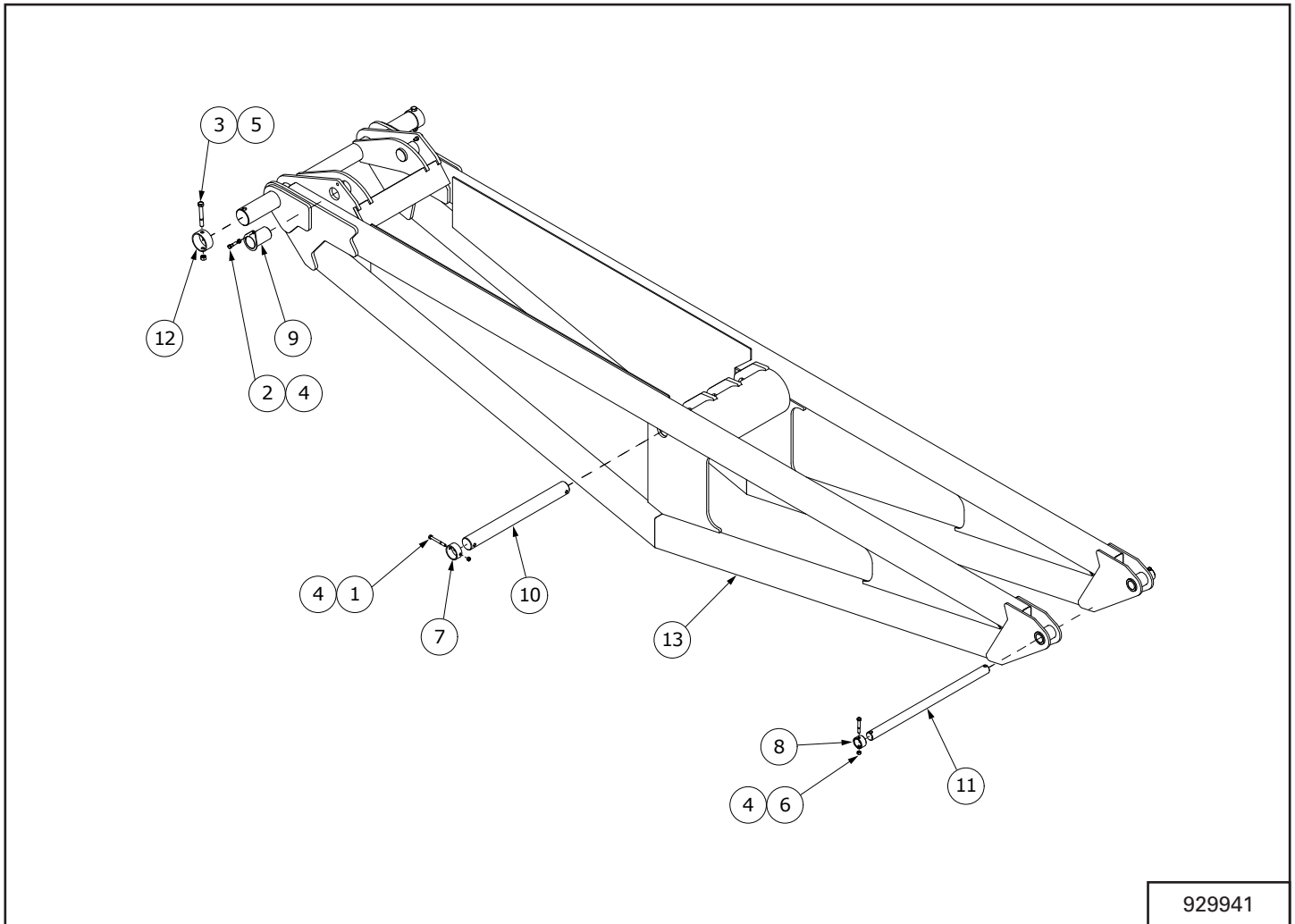

ITEM	PART NUMBER	DESCRIPTION	QTY.
1	811691	1/2" X 4 1/2" HEX BOLT (PL)	2
2	811791	1/2" X 2" HEX BOLT (PL)	2
3	812114	3/4" X 5 1/2" HEX BOLT (PL)	2
4	812364	1/2" LOCK NUT (PL)	6
5	812365	3/4" LOCK NUT (PL)	2
6	81629	1/2" X 3 1/2" HEX BOLT (PL)	2
7	905736	UNDERCARR PIN SLEEVE 3 1/6"ID X 3 1/2"OD X 1 1/2"	2
8	905807	UPPER LIFT ARM PIN COLLAR	2
9	929630	WELDT-3.000" DIA PIN	2
10	929942	PIN-3.000" DIA	1
11	930057	PIN-2.000" DIA	1
12	930113	TUBE-PIN SLEEVE	2
13	F2283	WELDT-UPPER LIFT ARM	1

**LIFT ARMS YOKE - 16124**

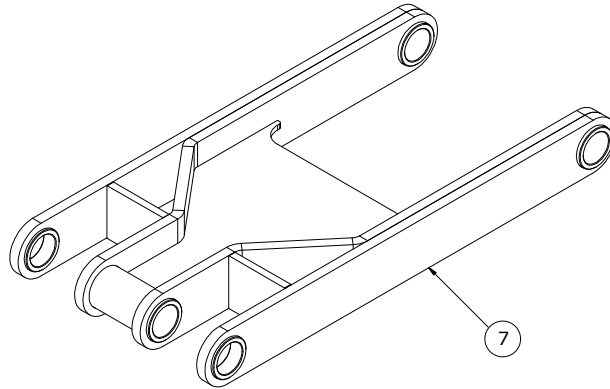

UPPER YOKE

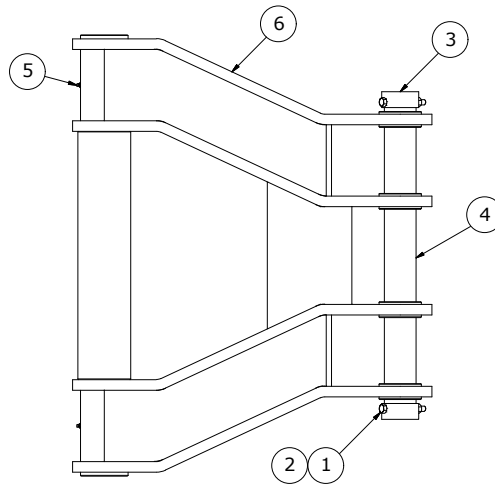

LOWER YOKE

930112, 929940

ITEM	PART NUMBER	DESCRIPTION	QTY.
1	811691	1/2" x 4 1/2" HEX BOLT (PL)	2
2	812364	1/2" LOCK NUT (PL)	2
3	905736	UNDERCARR PIN SLEEVE 3 1/6" ID x 3 1/2" OD x 1 1/2"	2
4	929942	PIN-3.000" DIA	1
5	967164	DRIVE-IN GREASE ZERK	2
6	F2298	WELDT-LOWERYOKE	1
7	F2297	WELDT-UPPERYOKE	1

**LIFT ARMS CYLINDERS - 16124**

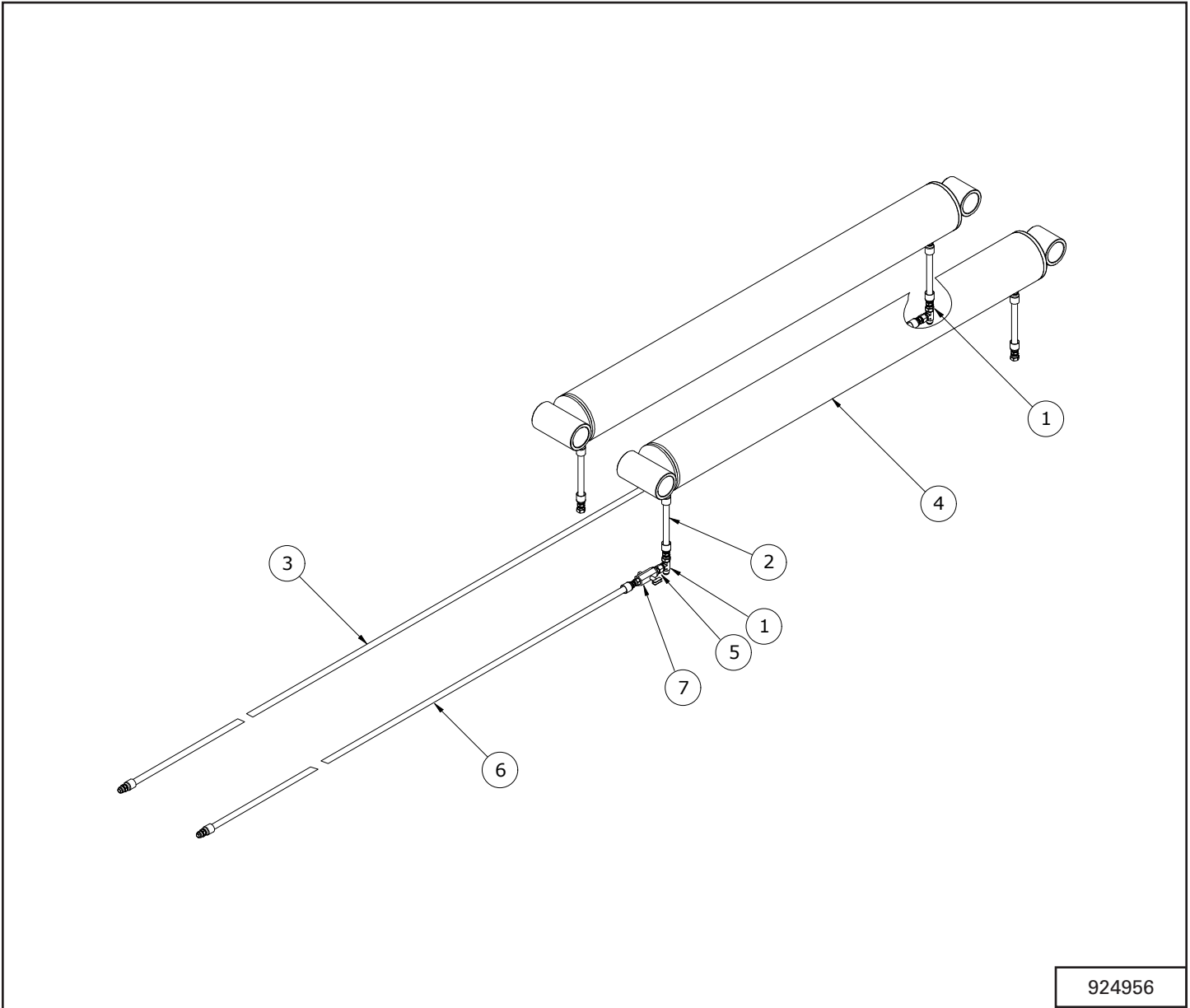

924956

ITEM	PART NUMBER	DESCRIPTION	QTY.
1	865341	TEE-10MJIC X -10MJIC X -10 FJIC	2
2	906103	HOSE-8 X -8MORB X -10JIC	4
3	930167	HOSE-8 X -10MJIC X -10MJIC	1
4	F2279	CYLINDER-6.5 X 58.5	2
5	960152	ADAPTOR STRAIGHT -10 MJIC X -8 MNPT	1
6	930168	HOSE-8 X -10MJIC X -8MPT	1
7	960118	-8 FNPT FLOW CONTROL VALVE (ONE WAY) (STEEL)	1

# TUBES - 1684

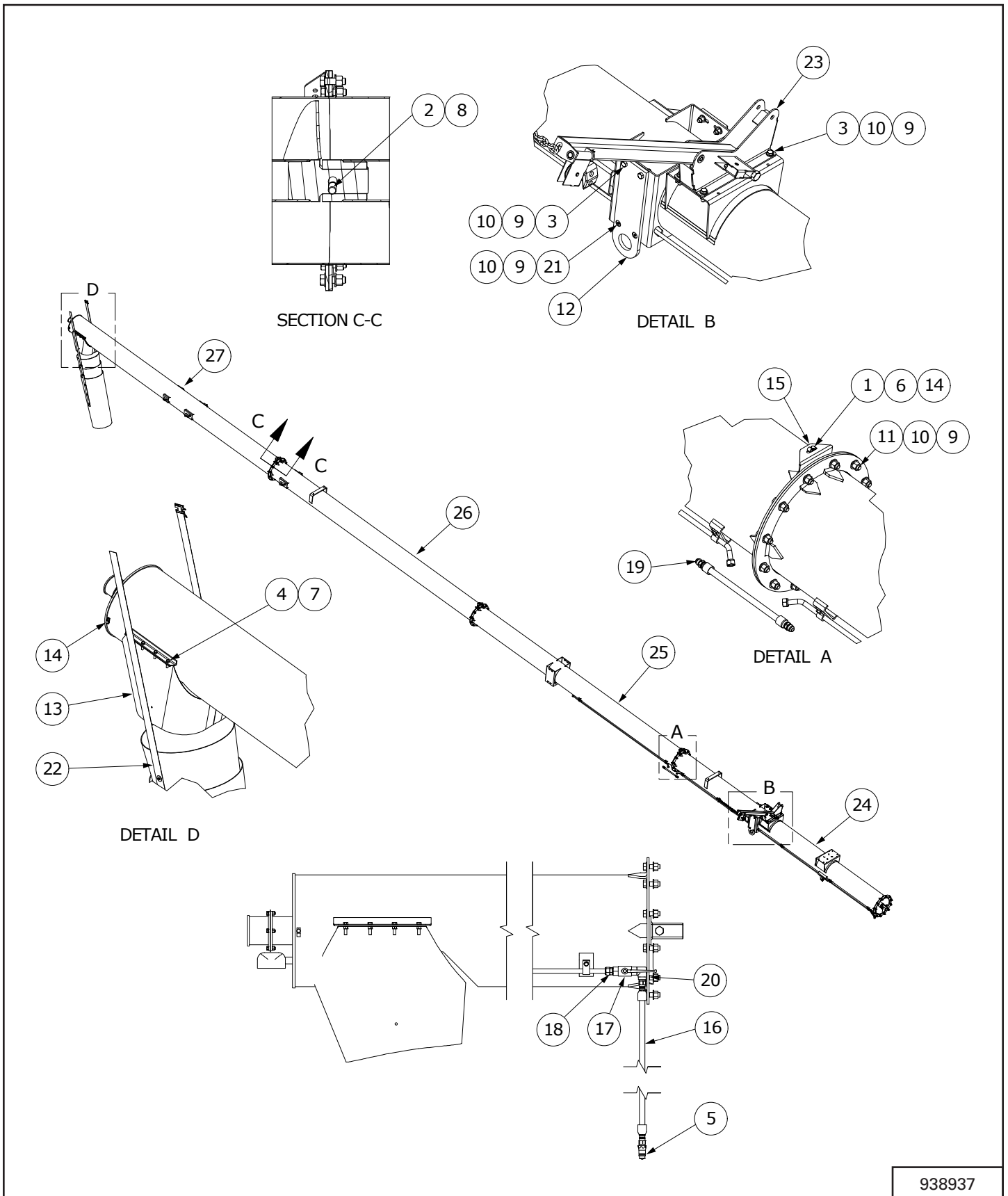

938937

ITEM	PART NUMBER	DESCRIPTION	QTY.
1	81549	5/16" X 3/4" HEX BOLT (PL)	3
2	84215	3/4" X 6" HEX BOLT GR.5 (PL)	4
3	84299	5/8" X 2" HEX BOLT GR.5 (PL)	8
4	811792	3/8" X 1 1/2" HEX BOLT GR.5 (PL)	8
5	812208	NIPPLE 1/2" BODY 1/2"-14 NPTF QUICK CONNECT	1
6	812362	5/16" LOCK NUT (PL)	3
7	812363	3/8" LOCK NUT (PL)	8
8	812365	3/4" LOCK NUT (PL)	4
9	812482	5/8" LOCK NUT (PL)	60
10	812639	WASHER 0.625 SAE FLAT BS PL	112
11	812946	BOLT HEX 0.625 UNC X 2.00 GR8PL	48
12	904736	UNDRCARR CONN PL 5/8 X 6 X 20 1/2"	2
13	906130	SPOUT	1
14	912832	7/16" CABLE CLIP	4
15	914882	BRKT-CABLE MOUNT BS16104	3
16	917746	HOSE-08 X -08MNPT X -08MNPT	1
17	960057	-08 FNPT 2 WAY BALL VALVE	1
18	960152	ADAPTOR STRAIGHT -10 MJIC X -8 MNPT	1
19	960162	HOSE-8 X -10MJIC X -10MJIC	1
20	960585	1/2" X 90 DEGREE STREET ELBOW (STEEL)	1
21	967284	BOLT FLAT HEAD SOCKET 5/8 X 1 3/4" (PL)	4
22	F0678	16" DOWNSPOUT ASSEMBLY	1
23	F1632	BOOM LIFT ASSEMBLY	1
24	F2675	ASSY - TUBE #1*	1
25	F2676	ASSY - TUBE #2*	1
26	F2677	ASSY - TUBE #3*	1
27	F2678	ASSY - TUBE #5*	1

\*The tubes for the BS1684 are labeled Tube #1 (intake), Tube #2, Tube #3, and Tube #5 (Discharge).

# TUBES - 16104

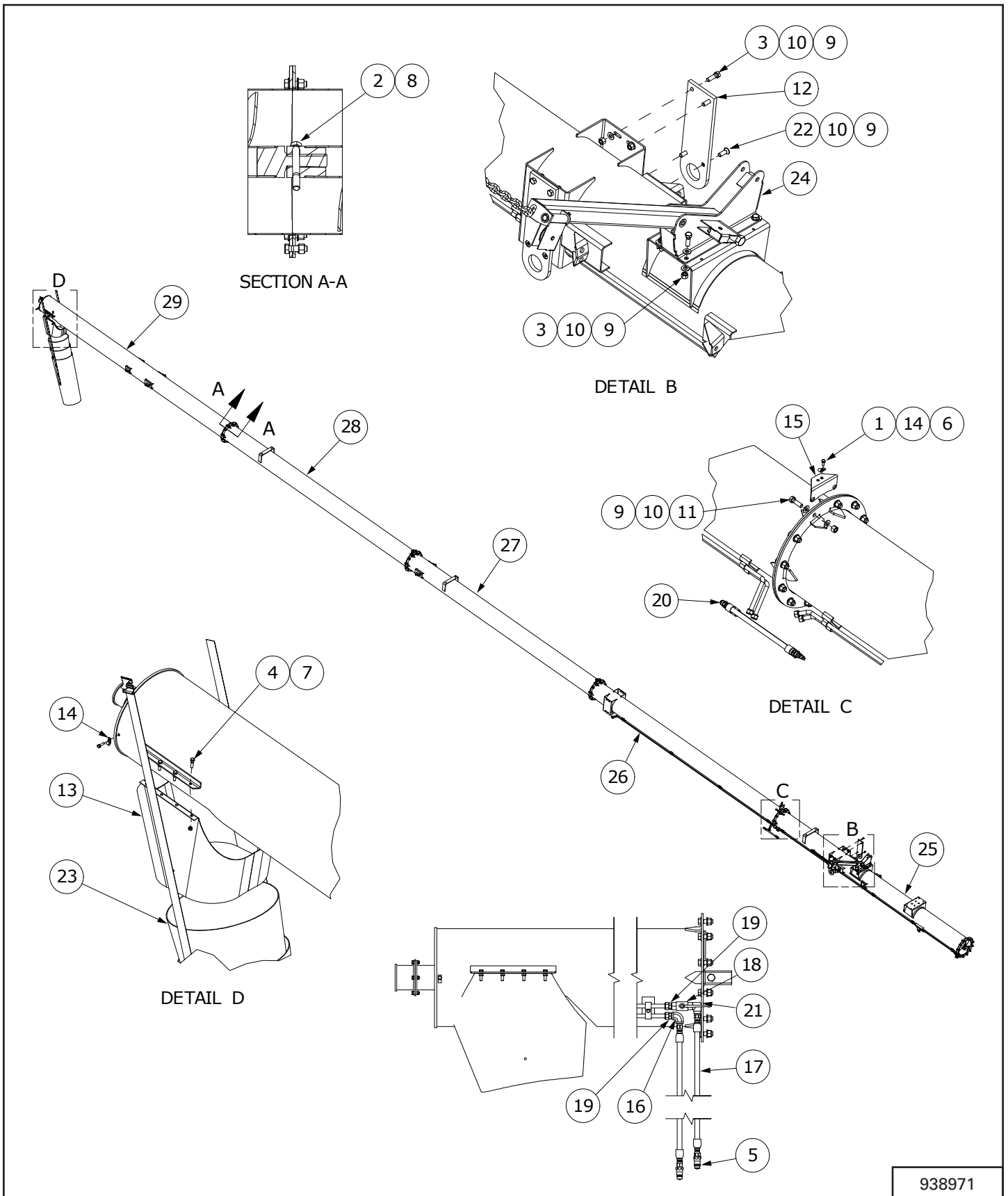

ITEM	PART NUMBER	DESCRIPTION	QTY.
1	81549	5/16" X 3/4" HEX BOLT (PL)	3
2	84215	3/4" X 6" HEX BOLT GR.5 (PL)	5
3	84299	5/8" X 2" HEX BOLT GR.5 (PL)	8
4	811792	3/8" X 1 1/2" HEX BOLT GR.5 (PL)	8
5	812208	NIPPLE 1/2" BODY 1/2"-14 NPTF QUICK CONNECT	2
6	812362	5/16" LOCK NUT (PL)	3
7	812363	3/8" LOCK NUT (PL)	8
8	812365	3/4" LOCK NUT (PL)	5
9	812482	5/8" LOCK NUT (PL)	72
10	812639	WASHER 0.625 SAE FLAT BS PL	136
11	812946	BOLT HEX 0.625 UNC X 2.00 GR8PL	60
12	904736	UNDRCARR CONN PL 5/8 X 6 X 20 1/2"	2
13	906130	SPOUT	1
14	912832	7/16" CABLE CLIP	4
15	914882	BRKT-CABLE MOUNT BS16104	3
16	914930	ELBOW-8FPT X -8 FPT	1
17	917746	HOSE-08 X -08MNPT X -08MNPT	2
18	960057	-08 FNPT 2 WAY BALL VALVE	1
19	960152	ADAPTOR STRAIGHT -10 MJIC X -8 MNPT	2
20	960162	HOSE-8 X -10MJIC X -10MJIC	2
21	960585	1/2" X 90 DEGREE STREET ELBOW (STEEL)	1
22	967284	BOLT FLAT HEAD SOCKET 5/8 X 1 3/4" (PL)	4
23	F0678	16" DOWNSPOUT ASSEMBLY	1
24	F1632	BOOM LIFT ASSEMBLY	1
25	F2680	ASSY - TUBE #1	1
26	F2681	ASSY - TUBE #2	1
27	F2677	ASSY - TUBE #3	1
28	F2682	ASSY - TUBE #4	1
29	F2678	ASSY - TUBE #5	1

# TUBES - 16124

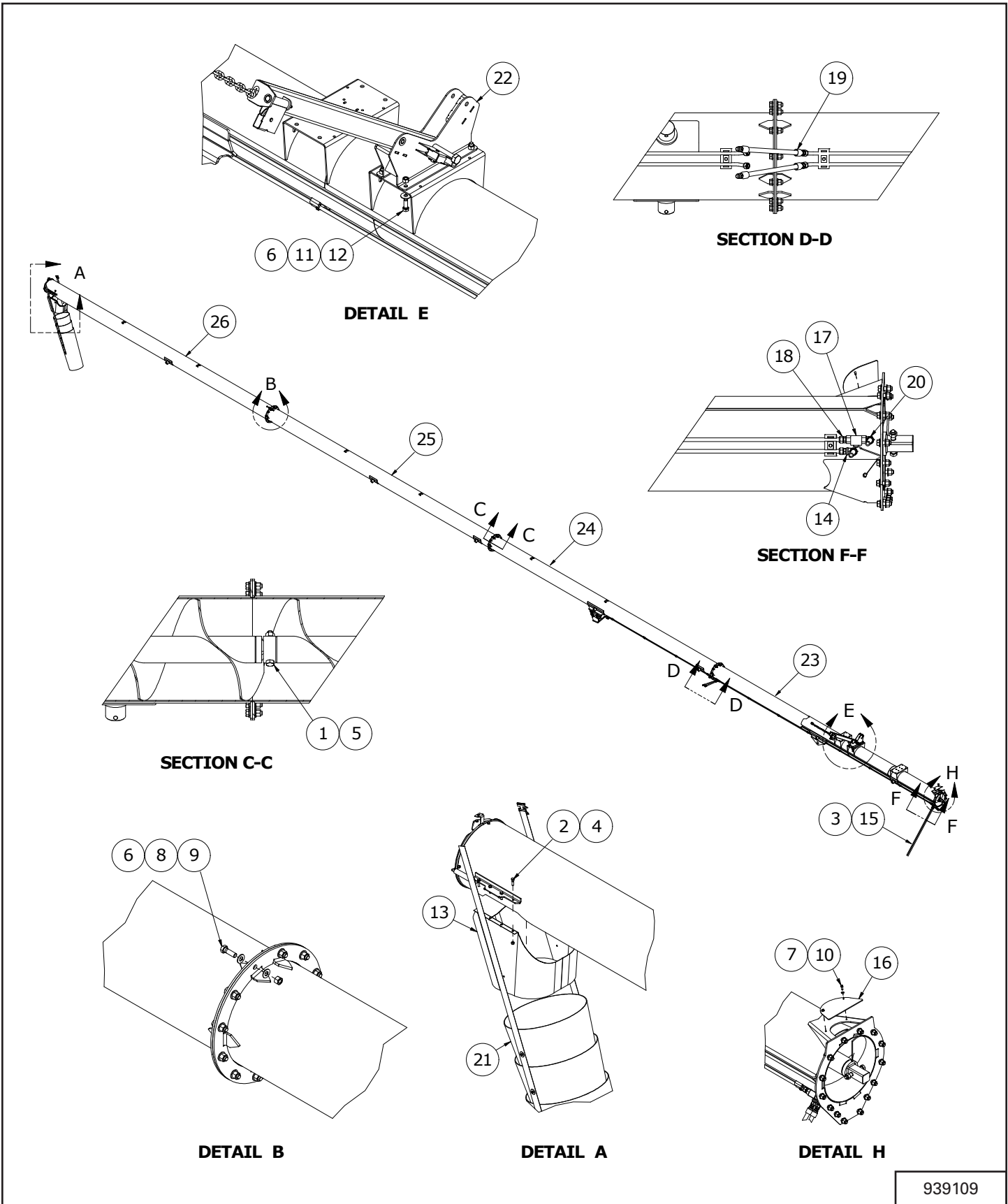

939109

ITEM	PART NUMBER	DESCRIPTION	QTY.
1	811751	3/4" X 5" HEX BOLT (PL)	4
2	811792	3/8" X 1 1/2" HEX BOLT GR.5 (PL)	8
3	812208	NIPPLE 1/2" BODY 1/2"-14 NPTF QUICK CONNECT	2
4	812363	3/8" LOCK NUT (PL)	8
5	812365	3/4" LOCK NUT (PL)	4
6	812482	5/8" LOCK NUT (PL)	54
7	812624	1/4" FLAT WASHER PL	2
8	812639	WASHER 0.625 SAE FLAT BS PL	100
9	812946	BOLT HEX 0.625 UNC X 2.00 GR8PL	50
10	81525	1/4" X 3/4" HEX BOLT (PL)	2
11	81678	5/8" FLAT WASHER STD (PL)	4
12	84270	5/8" X 1 3/4" HEX BOLT (PL)	4
13	906130	SPOUT	1
14	914930	ELBOW-8FPT X -8 FPT	1
15	917746	HOSE-08 X -08MNPT X -08MNPT	2
16	933069L	PLATE-COVER	1
17	960057	-08 FNPT 2 WAY BALL VALVE	1
18	960152	ADAPTOR STRAIGHT -10 MJIC X -8 MNPT	2
19	960162	HOSE-8 X -10MJIC X -10MJIC	2
20	960585	1/2" X 90 DEGREE STREET ELBOW (STEEL)	1
21	F0678	16" DOWNSPOUT ASSEMBLY	1
22	F2464	ASSY-LIFT BOOM	1
23	F2684	ASSY - TUBE #1	1
24	F2685	ASSY - TUBE #2	1
25	F2686	ASSY - TUBE #3	1
26	F2687	ASSY - TUBE #4	1

## TUBE SECTIONS - 1684

The tubes for the BS1684 are labeled Tube #1 (intake), Tube #2, Tube #3, and Tube #5 (Discharge).

### Tube #1 (Intake)

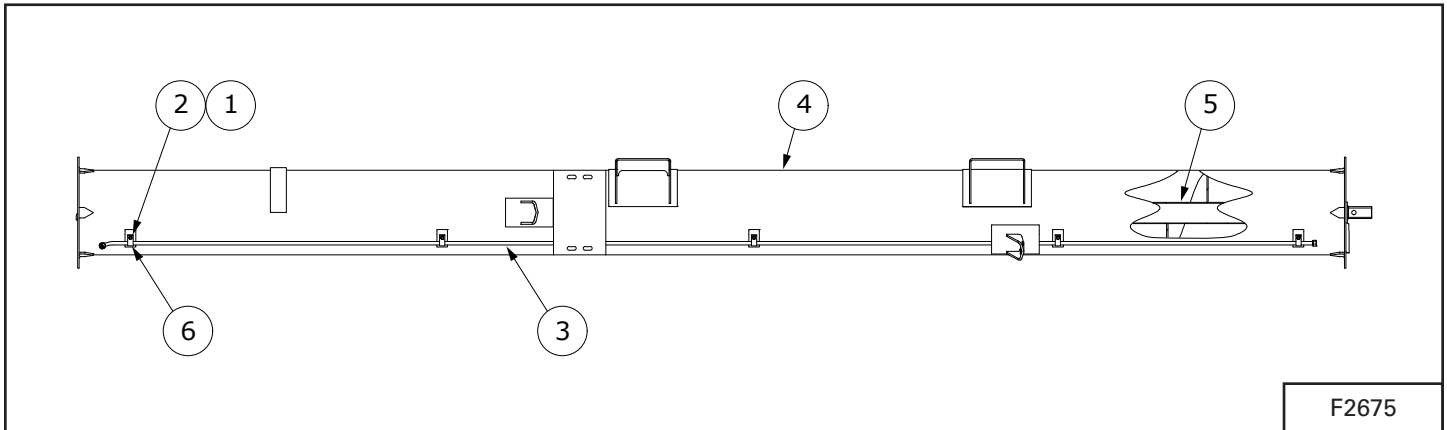

ITEM	PART NUMBER	DESCRIPTION	QTY.
1	812363	3/8" LOCK NUT (PL)	5
2	86170	3/8" X 1" HEX BOLT GR.5 (PL)	5
3	906104	HYD LINE 5/8"OD X 19'-2"	1
4	917068	TUBE WELDMENT #1	1
5	938199	WELDT-FLTG	1
6	960140	HYDRAULIC LINE CLAMP	5

### Tube #2

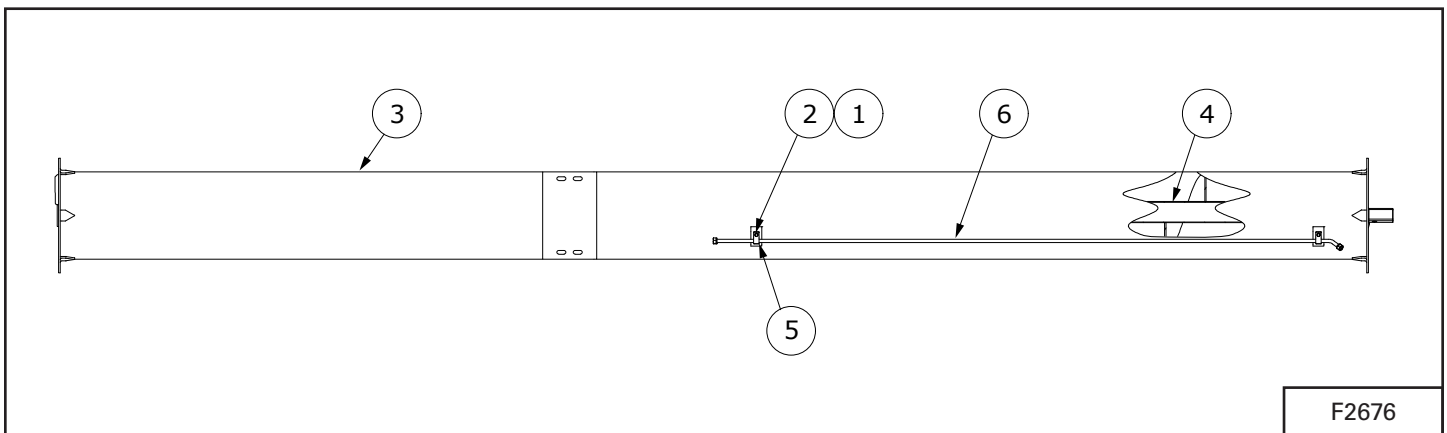

ITEM	PART NUMBER	DESCRIPTION	QTY.
1	812363	3/8" LOCK NUT (PL)	2
2	86170	3/8" X 1" HEX BOLT GR.5 (PL)	2
3	917066	TUBE WELDMENT #2	1
4	938199	WELDT-FLTG	1
5	960140	HYDRAULIC LINE CLAMP	2
6	960200	HYD LINE 5/8" OD X 9'-7"	1

**Tube #3**

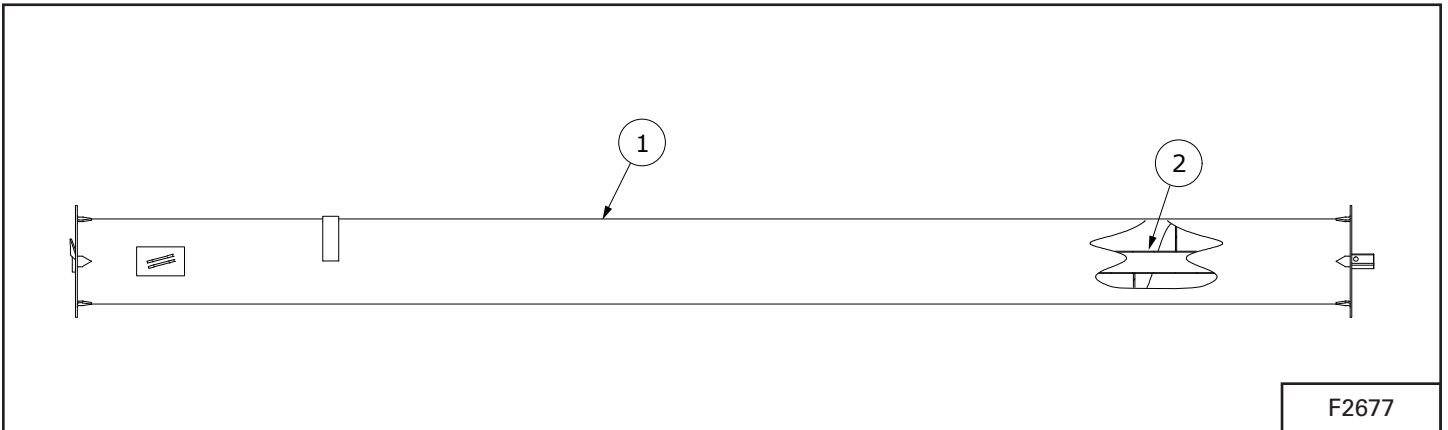

ITEM	PART NUMBER	DESCRIPTION	QTY.
1	914635	WELDT - TUBE #3	1
2	938199	WELDT-FLTG	1

**Tube #5 (Discharge)**

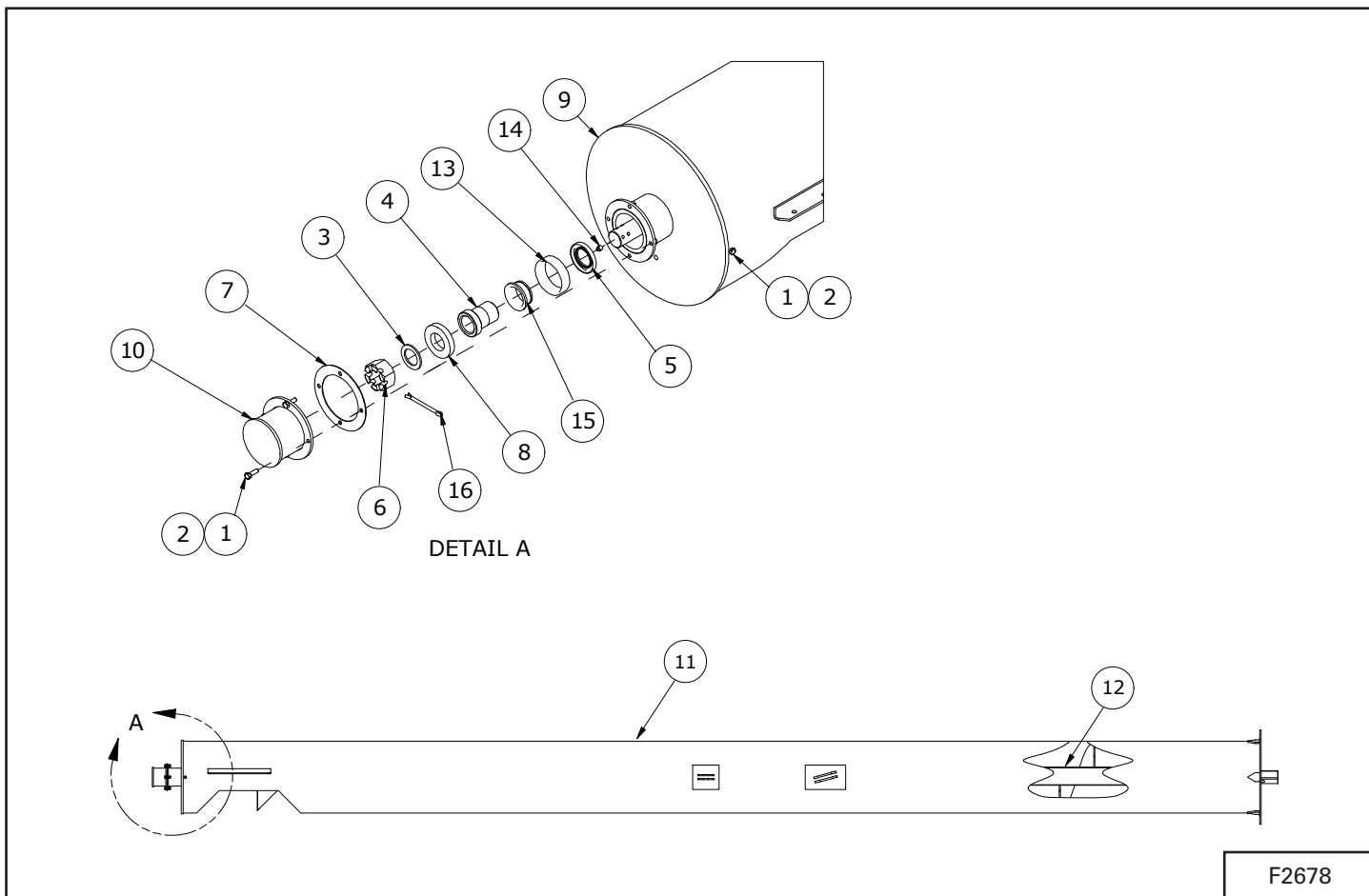

ITEM	PART NUMBER	DESCRIPTION	QTY.
1	812026	5/16" X 1" HEX BOLT (PL)	6
2	812362	5/16" LOCK NUT (PL)	6
3	9812445	WASHER - 1-1/2" X 10GA NARROW RIM (BR)	1
4	905906	END BEARING SLEEVE 1.515"ID X 2 1/4"OD X 2.88"	1
5	907052	OIL SEAL (CR17617)	1
6	907053	1 1/2" SLOTTED HEX NUT NF GR2 (BR)	1
7	907642	RUBBER GASKET (CTD#SE49)	1
8	914550L	PLATE - SPACER	1
9	914554	WELDT - TOP COVER	1
10	914556	WELDT - TOP FLANGE CAP	1
11	914637	TUBE WELDT #5	1
12	938196	WELDT-BS16" TOP FLTG	1
13	965252	INNER BEARING CUP (25520)	1
14	967164	DRIVE-IN GREASE ZERK	1
15	967205	INNER BEARING CONE (25580)	1
16	9812436	1/4" X 2 1/2" COTTER PIN (PL)	1

## TUBE SECTIONS - 16104

The tubes for the BS16104 are labeled Tube #1 (intake), Tube #2, Tube #3, Tube #4, and Tube #5 (Discharge).

### Tube #1 (Intake)

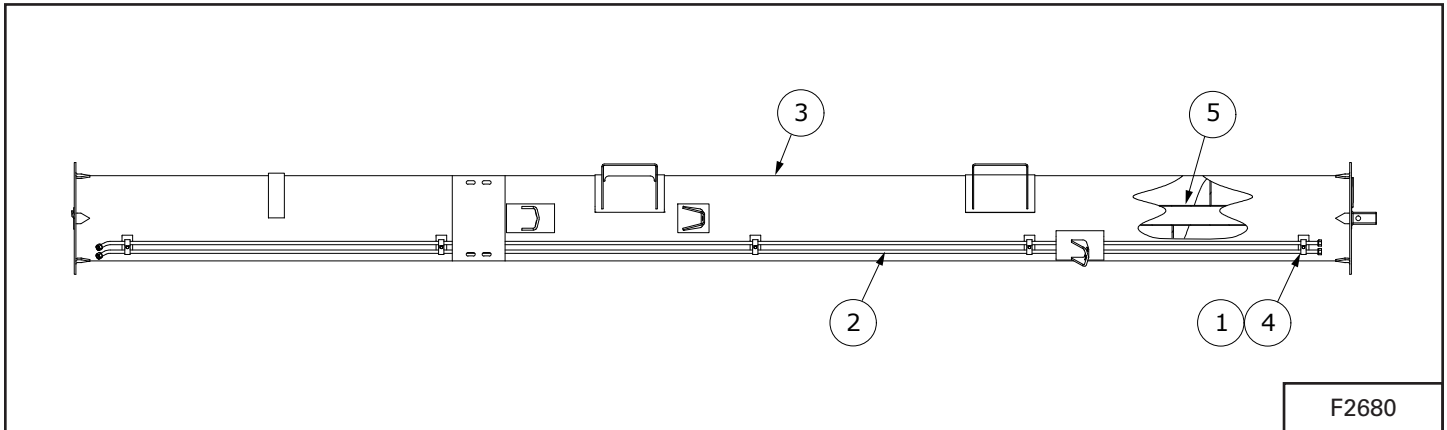

ITEM	PART NUMBER	DESCRIPTION	QTY.
1	81549	5/16" X 3/4" HEX BOLT (PL)	5
2	906104	HYD LINE 5/8"OD X 19'-2"	2
3	914629	TUBE WELDMENT #1	1
4	914818	BRKT - HYD HOSE CLAMP	5
5	938199	WELDT-FLTG	1

### Tube #2

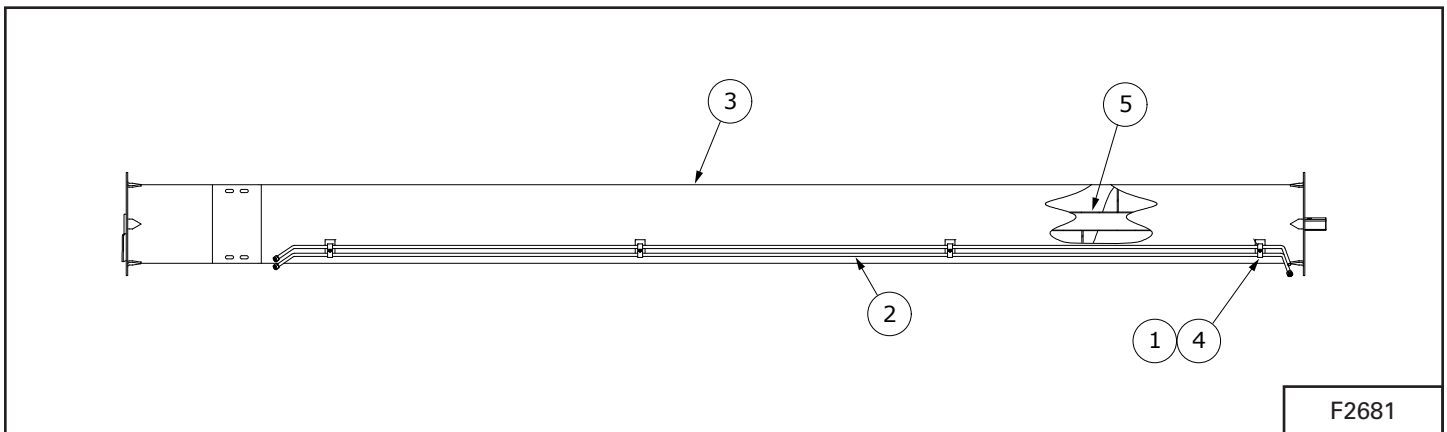

ITEM	PART NUMBER	DESCRIPTION	QTY.
1	81549	5/16" X 3/4" HEX BOLT (PL)	4
2	906105	HYD LINE 5/8"OD X 19'-2"	2
3	914634	TUBE WELDMENT #2	1
4	914818	BRKT - HYD HOSE CLAMP	4
5	938199	WELDT-FLTG	1

**Tube #3**

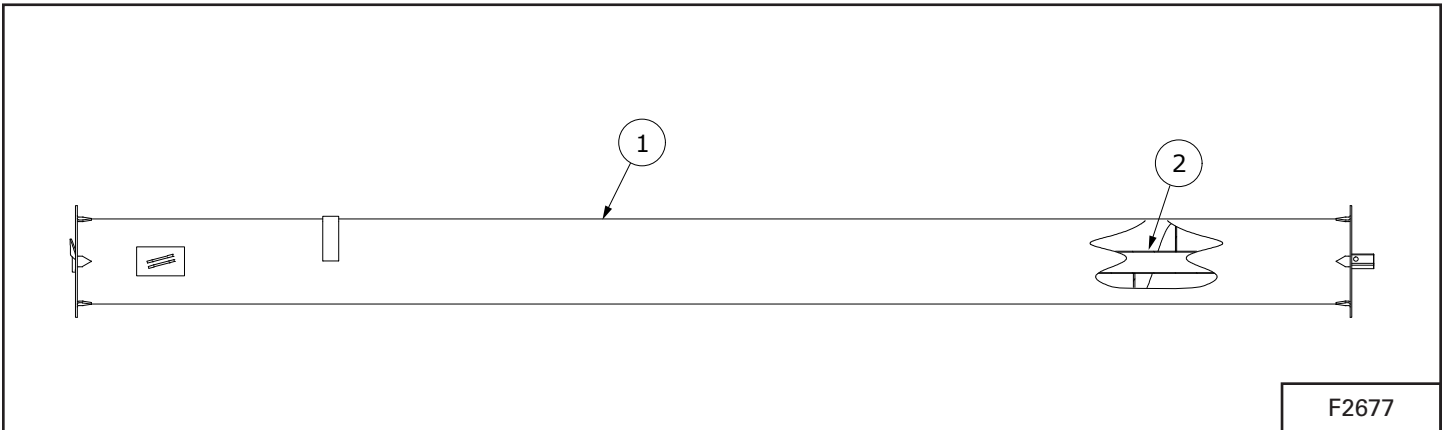

ITEM	PART NUMBER	DESCRIPTION	QTY.
1	914635	WELDT - TUBE #3	1
2	938199	WELDT-FLTG	1

**Tube 4**

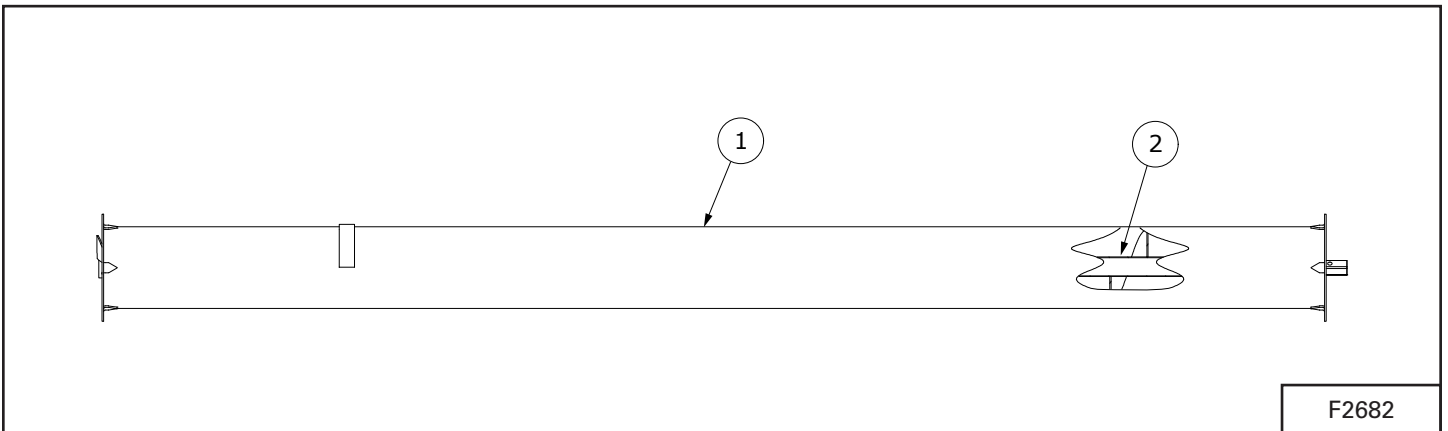

ITEM	PART NUMBER	DESCRIPTION	QTY.
1	914636	WELDT - TUBE #4	1
2	938199	WELDT-FLTG	1

**Tube #5 (Discharge)**

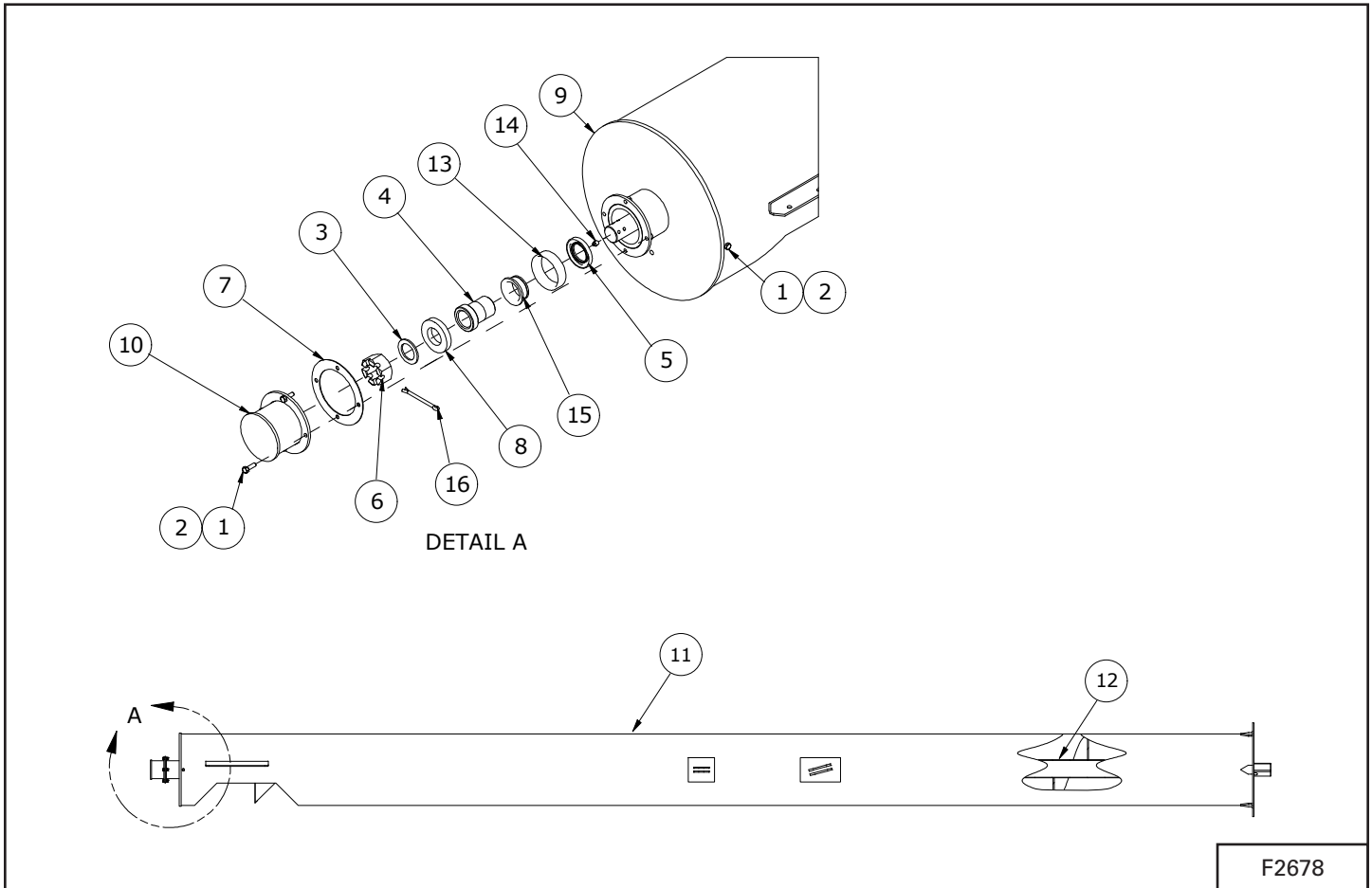

ITEM	PART NUMBER	DESCRIPTION	QTY.
1	812026	5/16" X 1" HEX BOLT (PL)	6
2	812362	5/16" LOCK NUT (PL)	6
3	9812445	WASHER - 1-1/2" X 10GA NARROW RIM (BR)	1
4	905906	END BEARING SLEEVE 1.515"ID X 2 1/4"OD X 2.88"	1
5	907052	OIL SEAL (CR17617)	1
6	907053	1 1/2" SLOTTED HEX NUT NF GR2 (BR)	1
7	907642	RUBBER GASKET (CTD#SE49)	1
8	914550L	PLATE - SPACER	1
9	914554	WELDT - TOP COVER	1
10	914556	WELDT - TOP FLANGE CAP	1
11	914637	TUBE WELDT #5	1
12	938196	WELDT-BS16" TOP FLTG	1
13	965252	INNER BEARING CUP (25520)	1
14	967164	DRIVE-IN GREASE ZERK	1
15	967205	INNER BEARING CONE (25580)	1
16	9812436	1/4" X 2 1/2" COTTER PIN (PL)	1

## TUBE SECTIONS - 16124

The tubes for the BS16124 are labeled Tube #1 (intake), Tube #2, Tube #3, Tube #4 (Discharge).

### Tube #1 (Intake)

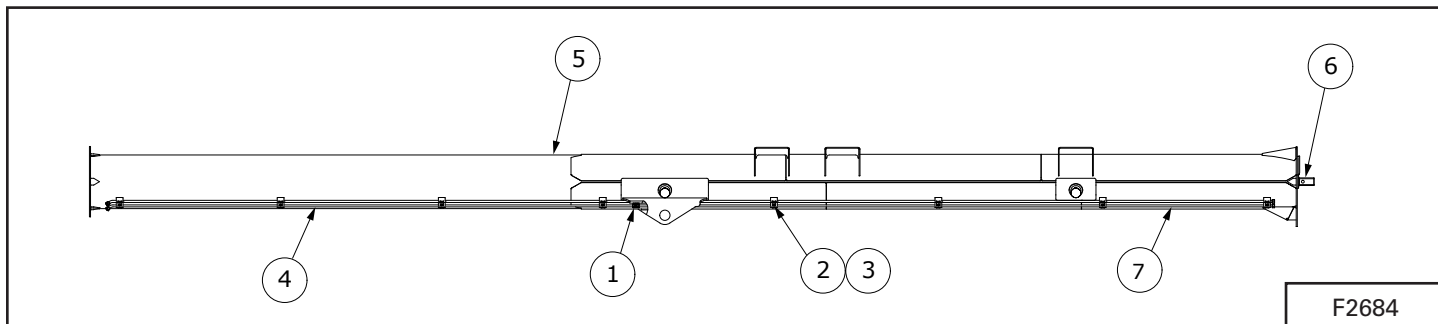

F2684

ITEM	PART NUMBER	DESCRIPTION	QTY.
1	812711	JIC UNION -10-10	2
2	81549	5/16" X 3/4" HEX BOLT (PL)	8
3	914818	BRKT - HYD HOSE CLAMP	8
4	930041	5/8" X 13' HYD LINE (JIC FEMALE ENDS)	2
5	933313	WELDT-TUBE #1	1
6	938185	WELDT-BS16" FLTG	1
7	960467	HYD LINE 5/8" X 15'-10"	2

### Tube #2

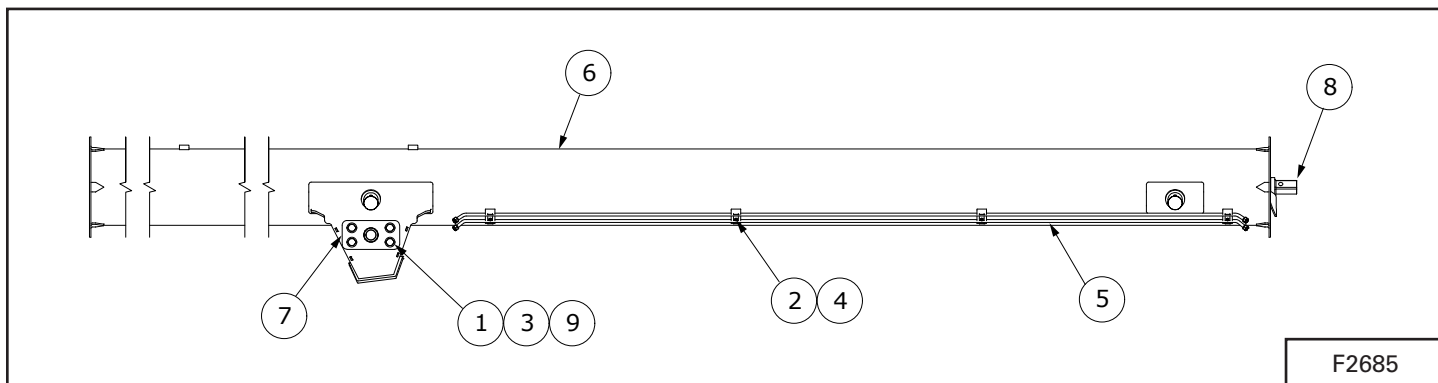

F2685

ITEM	PART NUMBER	DESCRIPTION	QTY.
1	812303	1" X 3" HEX BOLT (PL)	8
2	81549	5/16" X 3/4" HEX BOLT (PL)	4
3	84522	1" ID SAE FLAT WASHER (PL)	8
4	914818	BRKT - HYD HOSE CLAMP	4
5	929151	HYD LINE 5/8"OD X 14'	2
6	929874	TUBE WELDMENT #2	1
7	930031	WELDT-LIFT ARM PIVOT MOUNT	2
8	938185	WELDT-BS16" FLTG	1
9	967148	1" LOCK NUT (PL)	8

**Tube #3**

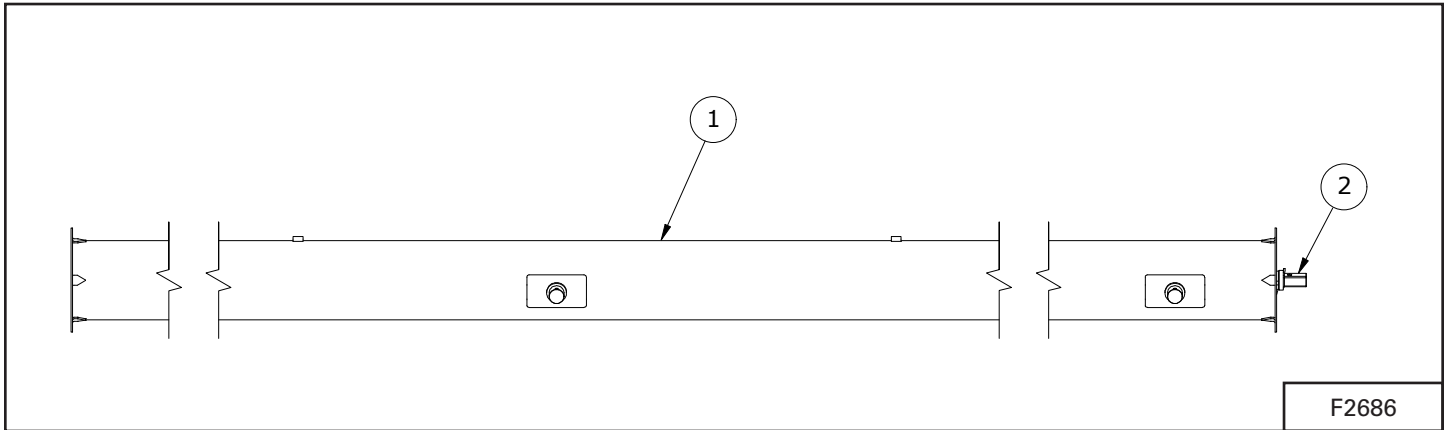

F2686

ITEM	PART NUMBER	DESCRIPTION	QTY.
1	929875	TUBE WELDMENT #3	1
2	938185	WELDT-BS16" FLTG	1

**Tube #4 (Discharge)**

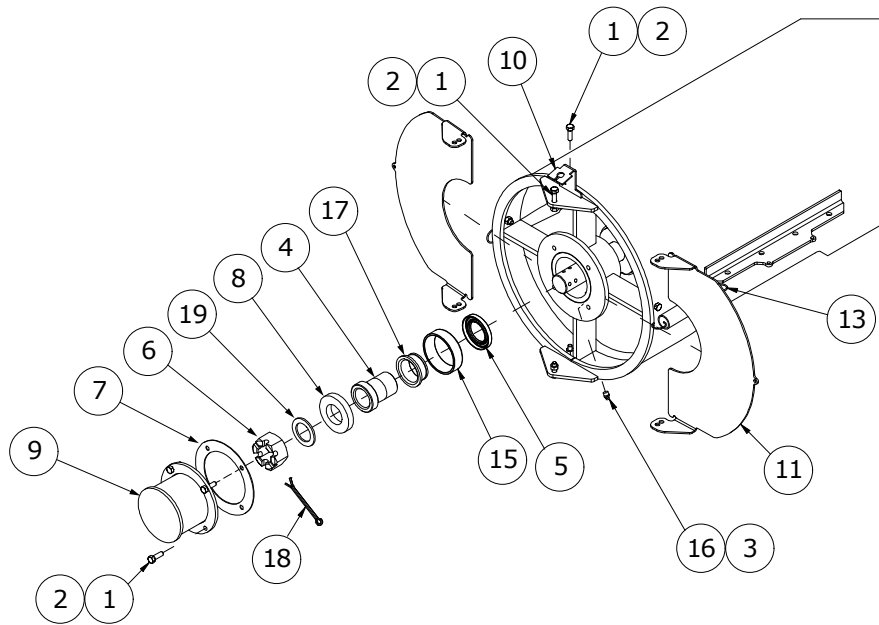

DETAIL A

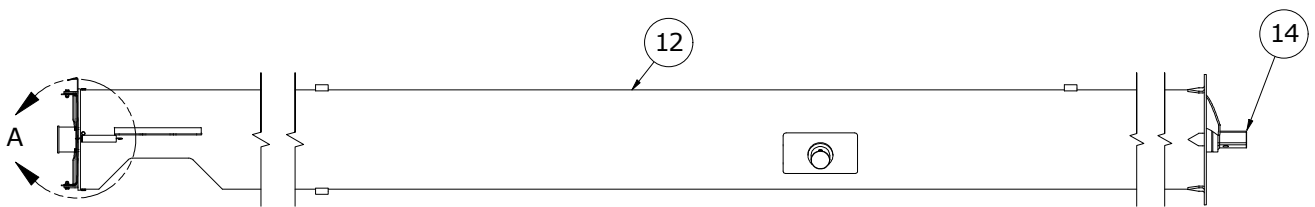

F2687

ITEM	PART NUMBER	DESCRIPTION	QTY.
1	812026	5/16" X 1" HEX BOLT (PL)	10
2	812362	5/16" LOCK NUT (PL)	10
3	904902	GREASE GRADE 2 (NOT SHOWN)	10g
4	905906	END BEARING SLEEVE 1.515"ID X 2 1/4"OD X 2.88"	1
5	907052	OIL SEAL (CR17617)	1
6	907053	1 1/2" SLOTTED HEX NUT NF GR2 (BR)	1
7	907642	RUBBER GASKET (CTD#SE49)	1
8	914550L	PLATE - SPACER	1
9	914556	WELDT - TOP FLANGE CAP	1
10	929723	WELDT-OVERFLOW END CAP	1
11	929730	BRKT-OVERFLOW DOOR	2
12	929876	TUBE WELDT #4	1
13	931497	SPRING-OVERFLOW DOOR	2
14	938188	WELDT-BS16"TOP FLTG	1
15	965252	INNER BEARING CUP (25520)	1
16	967164	DRIVE-IN GREASE ZERK	1
17	967205	INNER BEARING CONE (25580)	1
18	9812436	1/4" X 2 1/2" COTTER PIN (PL)	1
19	9812445	WASHER - 1-1/2" X 10GA NARROW RIM (BR)	1

**HOPPER LIFT ARM - 1684, 16104**

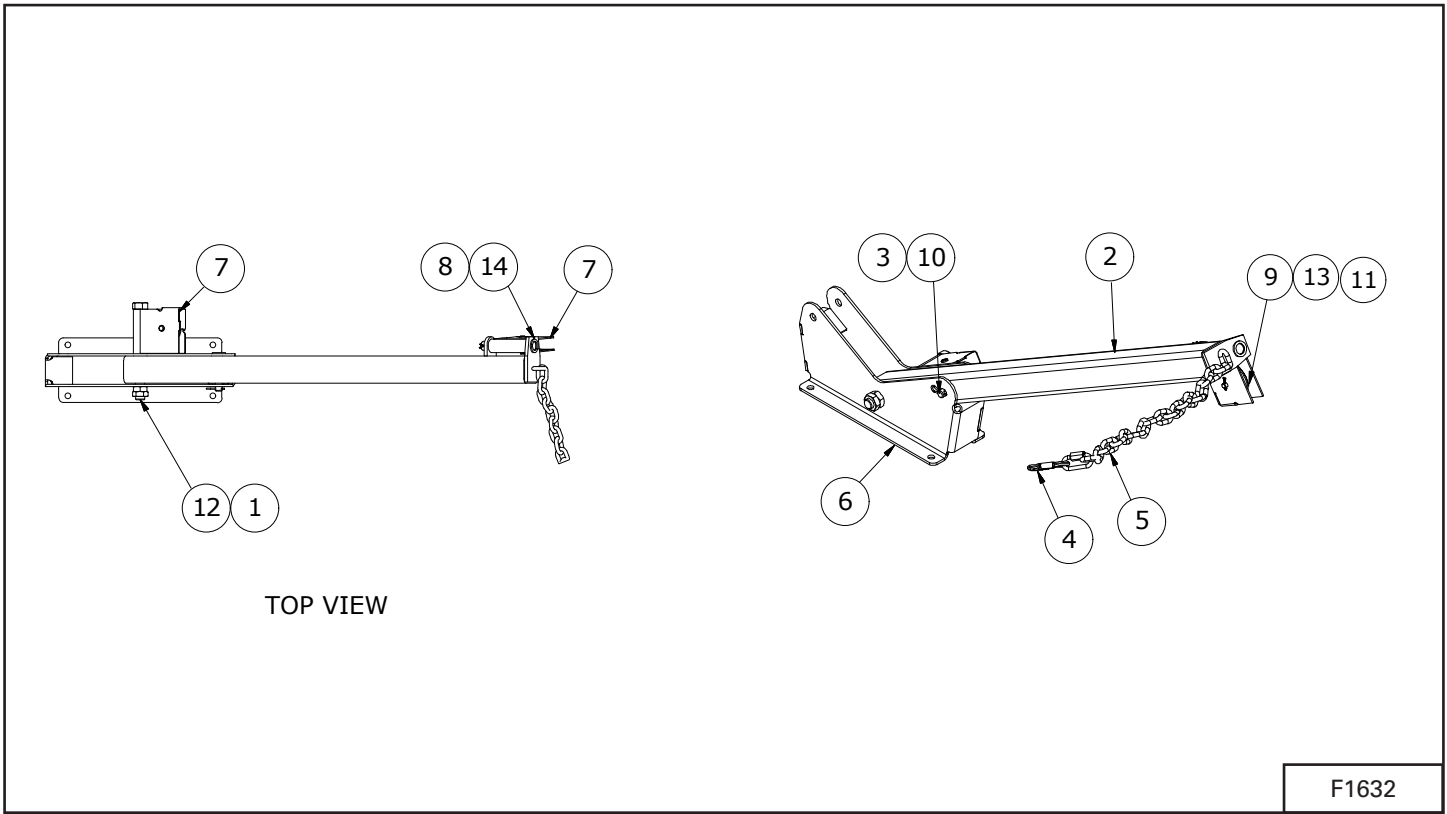

ITEM	PART NUMBER	DESCRIPTION	QTY.
1	84051	1" HEX JAM NUT GR2	2
2	905815	ARM WELDT	1
3	905821	PIN ROD WELDT	1
4	909171	CABLE HOOK ASSEMBLY (1 TON)	1
5	909172	3/8" QUICK LINK	1
6	914597	WELDT-HOPPER LIFT ARM MOUNT	1
7	914619	WELDT-PULLEY HOLDER	2
8	960111	CYLINDER PIN WELDT	1
9	960913	1/2" X 1 13/16" CLEV PIN (PL)	2
10	961012	#16 HAIR PIN CLIP	1
11	961846	1/2"ID X 3 1/2"OD X 1 1/8" CBLE PULLEY	2
12	967233	1" X 10" HEX BOLT (PL)	1
13	9812430	1/8" X 1" COTTER PIN (PL)	2
14	9812433	3/16" X 1 1/2" COTTER PIN	1

**HOPPER LIFT ARM - 16124**

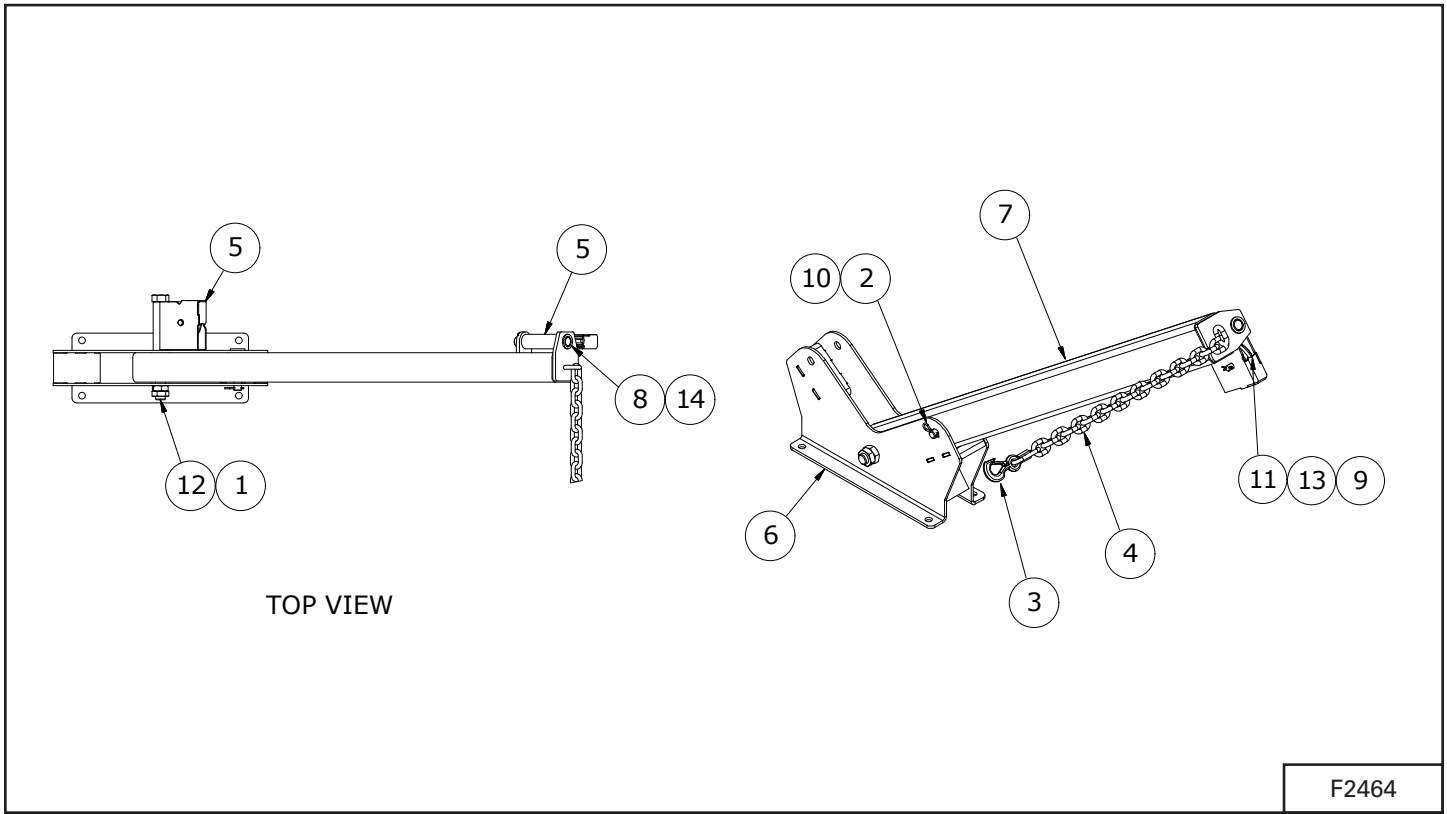

F2464

ITEM	PART NUMBER	DESCRIPTION	QTY.
1	84051	1" HEX JAM NUT GR2	2
2	905821	PIN WELDMENT 0.750" DIA	1
3	909171	CABLE HOOK ASSEMBLY (1 TON)	1
4	909172	3/8" QUICK LINK	1
5	914619	WELDT-PULLEY HOLDER	2
6	933706	WELDT-LIFT ARM MOUNT	1
7	933711	ARM WELDT	1
8	960111	CYLINDER PIN WELDT 1.000" DIA	1
9	960913	CLEVIS PIN, 1/2" X 2" (PL)	2
10	961012	#16 HAIR PIN CLIP	1
11	961846	1/2"ID X 3 1/2"OD X 1 1/8" CBLE PULLEY	2
12	967233	1" X 10" HEX BOLT (PL)	1
13	9812430	1/8" X 1" COTTER PIN (PL)	2
14	9812433	3/16" X 1 1/2" COTTER PIN	1

# INTAKE AUGER

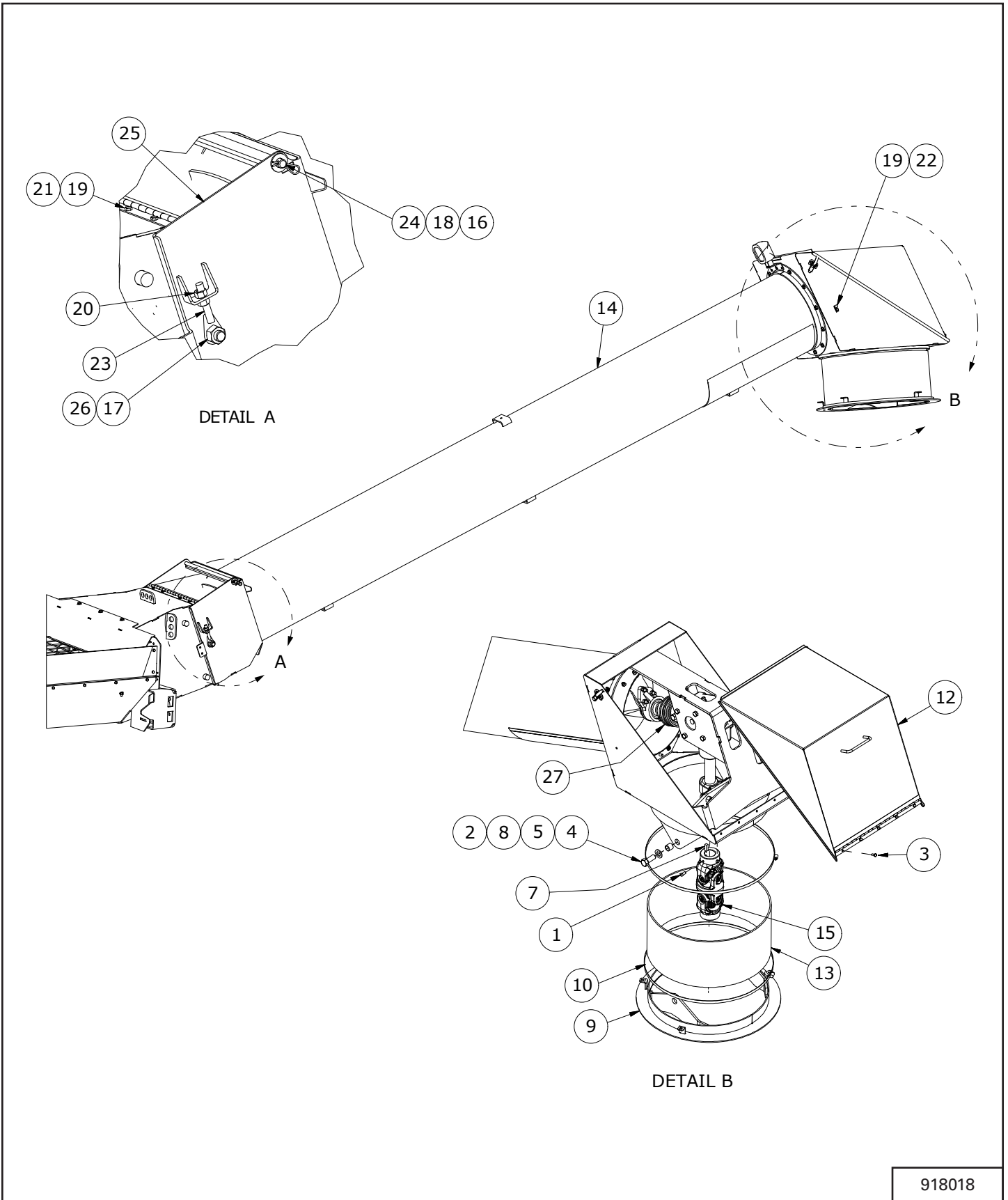

918018

ITEM	PART NUMBER	DESCRIPTION	QTY.
1	812037	3/8" X 3/4" SQHDCUP SETSCREW (PL)	2
2	812365	3/4" LOCK NUT (PL)	2
3	81525	1/4" X 3/4" HEX BOLT (PL)	5
4	84050	3/4" S.A.E. FLAT WASHER (PL)	4
5	84467	3/4" X 2" HEX BOLT (PL)	2
6	904578	GEAR OIL - SAE 75W-90 SYNTHETIC (NOT SHOWN)	1
7	909294	KEY - INT AUG TO MAIN AUG 3/8" X 3/8" X 1 1/4"	1
8	912503	UNDERCARRIAGE SPACER	2
9	914405	WELDT-INPUT BOX PIVOT - 1684, 16104	1
	937120	WELDT-INPUT BOX PIVOT - 16124	1
10	914429	CLAMP HOSE-2.06 TO 21.25	2
11	914443	CHAIN-COUPLING DOUBLE 60H	1
12	916894	WELDT-ELBOW ACCESS DOOR	1
13	917038	COVER-INPUT BOX PIVOT - 1684, 16104	1
	939719	COVER-INPUT BOX PIVOT - 16124	1
14	918019	ASSY - BS16 INPUT TUBE	1
15	930526	DOUBLE JOINT - 50 DEGREE CAT 4	1
16	12780	#7 HAIR PIN CLIP	1
17	812365	3/4" LOCK NUT (PL)	2
18	812639	WASHER 0.625 SAE FLAT BS PL	1
19	81525	1/4" X 3/4" HEX BOLT (PL)	6
20	81636	1/2" HEX NUT (PL)	4
21	84498	1/4" LOCK NUT (PL)	4
22	912832	7/16" CABLE CLIP	1
23	914449	WELDT - HOPPER ADJUSTMENT	2
24	916997	PIVOT COVER PIN WELDMENT 0.625" DIA	1
25	920093	WELDT-HINGED COVER	1
26	967437	3/4" X 1 5/8" HEX BOLT (PL)	2
27	914443	CHAIN-COUPLING DOUBLE 60H	1

# INTAKE AUGERTUBE

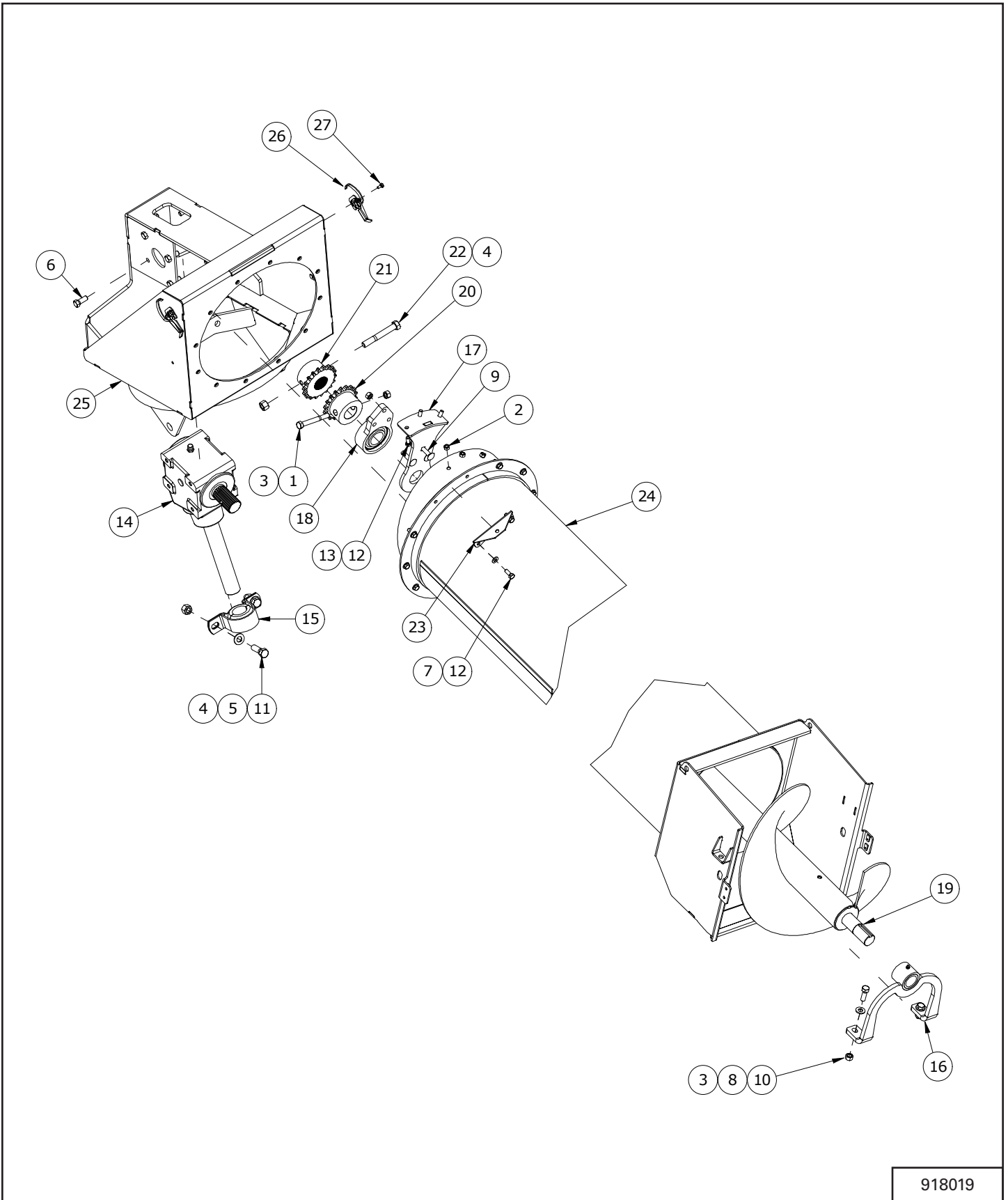

ITEM	PART NUMBER	DESCRIPTION	QTY.
1	811752	1/2" X 4" HEX BOLT (PL)	1
2	812363	3/8" LOCK NUT (PL)	3
3	812364	1/2" LOCK NUT (PL)	3
4	812482	5/8" LOCK NUT (PL)	3
5	812639	WASHER 0.625 SAE FLAT BS PL	2
6	81620	1/2" X 1 1/4" HEX BOLT PL	8
7	84039	WASHER - 3/8" SAE FLAT (PL)	12
8	84048	1/2" SAE FLAT WASHER (PL)	2
9	84243	7/16" X 2" CARRIAGE BOLT GR5 (PL)	3
10	84277	1/2" X 1 1/2" HEX BOLT (PL)	2
11	84299	5/8" X 2" HEX BOLT GR.5 (PL)	2
12	86170	3/8" X 1" HEX BOLT GR.5 (PL)	15
13	86273	7/16" LOCK NUT (PL)	3
14	905881	4168 GEARBOX-UPPER	1
15	905951	BRG & FLANGE SET 1 3/4" WOODEN	1
16	914462	WELDT - INTAKE FLTG HOLDER	1
17	914731	WELDT - HANGER BRKT	1
18	914744	BEARING-1.75 ID FLANGE	1
19	915954	WELDT - INTAKE FLTG	1
20	917026	SPROCKET-COUPPLING 60H W/BORE	1
21	917027	SPROCKET-COUPPLING 60H W/SPLINE	1
22	917936	5/8" X 4 1/2" HEX BOLT (PL) GR8	1
23	918383	BRKT-INTAKE LIGHT MOUNT	1
24	924669	INT AUG TUBE WELDT	1
25	930507	WELDT-INPUT BOX ELBOW	1
26	931901	LATCH-SLOTTED	2
27	81523	1/4" X 1/2" HEX BOLT (PL)	4

# HOPPER

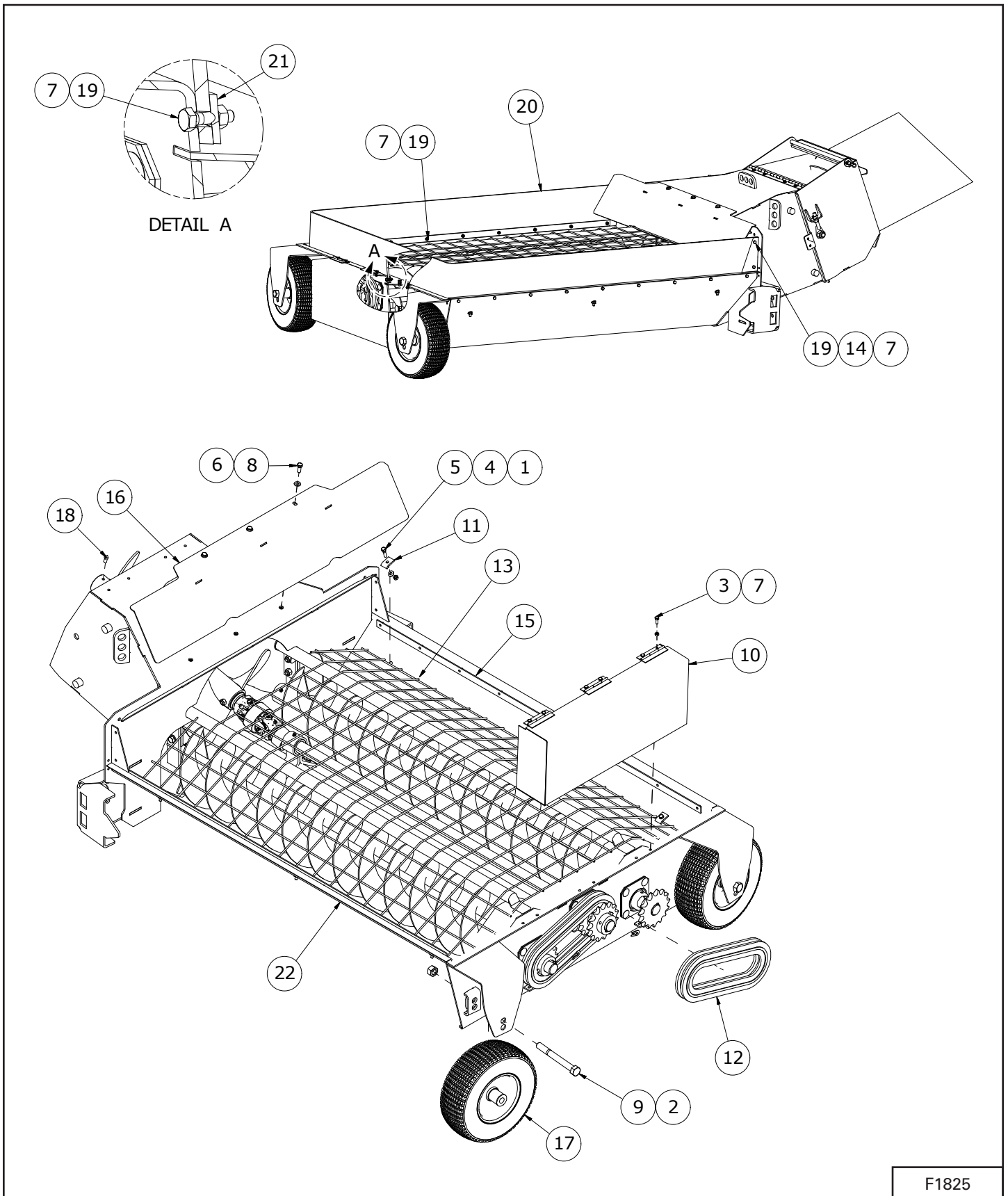

F1825

ITEM	PART NUMBER	DESCRIPTION	QTY.
1	812362	5/16" LOCK NUT (PL)	6
2	812365	3/4" LOCK NUT (PL)	2
3	81525	1/4" X 3/4" HEX BOLT (PL)	6
4	81546	5/16" FLAT WASHER (PL)	6
5	81552	5/16" X 1 1/4" HEX BOLT (PL)	6
6	84039	WASHER - 3/8" SAE FLAT (PL)	3
7	84498	1/4" LOCK NUT (PL)	34
8	86170	3/8" X 1" HEX BOLT GR.5 (PL)	3
9	902615	HEX BOLT-3/4 X 7" (PL)	2
10	906011	CHAIN GUARD COVER WELDT	1
11	910898	CAGE MOUNTING PL	6
12	914372	ROLLER CHAIN - 80H	2
13	914506	GUARD-HOPPER FLIGHTING	1
14	812624	1/4" FLAT WASHER PL	4
15	914768L	RUBBER REINFORCEMENT	2
16	916936	WELDT-HYD HOSE SHIELD	1
17	966851	TIRE W/WHEEL 13/500X6	2
18	9812378	3/8" X 3/4" SQ HD SET SCREW SER	4
19	81527	1/4" X 1" HEX BOLT (PL)	28
20	917748	RUBBER-HOPPER EDGING	1
21	917749L	PLATE: RUBBER REINFORCEMENT	3
22	914521	ASSY - 16" MULTI FLIGHTING HOPPPER (BEFORE PAINT)	1

# HOPPER FLIGHTING

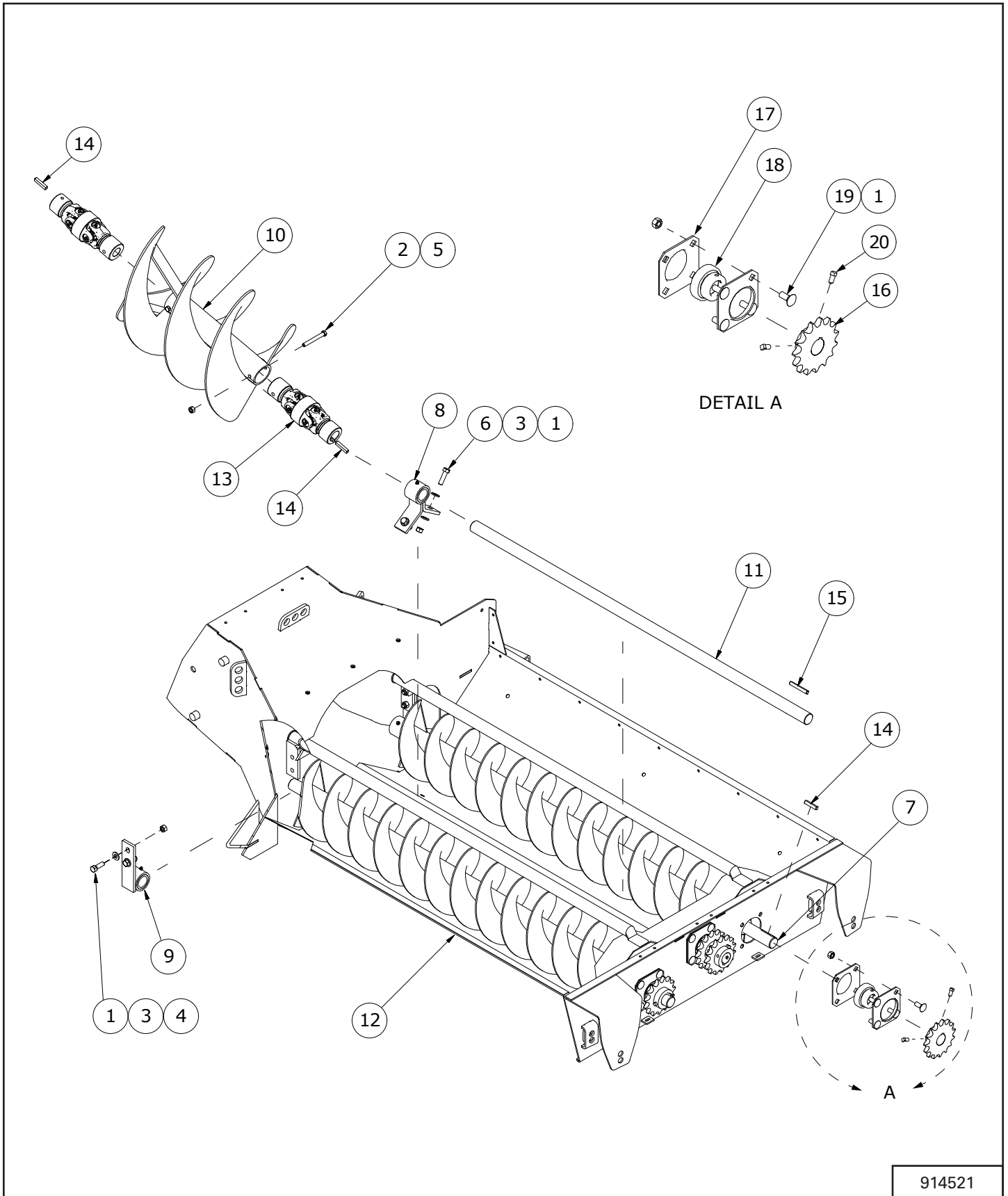

914521

ITEM	PART NUMBER	DESCRIPTION	QTY.
1	812364	1/2" LOCK NUT (PL)	18
2	81607	7/16" X 3 1/2" HEX BOLT GR5 PL	2
3	84048	1/2" SAE FLAT WASHER (PL)	8
4	84277	1/2" X 1 1/2" HEX BOLT (PL)	4
5	86273	7/16" LOCK NUT (PL)	2
6	87553	1/2" X 1.75" HEX BOLT UNC GR5 (PL)	2
7	905980	OUTR FLTG WELDT	2
8	906003	CENTER SHAFT HOLDER	1
9	906007	OUTER FLIGHTING HOLDER	2
10	914472	WELDT - PIVOT FLTG	1
11	914479	CENTER DRIVE SHAFT 01 1/2 X 59 7/8"	1
12	914520	WELDT-HOPPER	1
13	914565	CV JOINT - CAT 3, 50 DEG E4BL	2
14	914643	KEY - 3/8" X 3/8" X 2"	4
15	914739	KEY - 3/8" X 3/8" X 3"	1
16	960719	H80B15 SPROCKET (1.5" BORE)	4
17	967260	3.15"Ø BEARING FLANGE	6
18	968627	1 1/2" BRG W/ COLLAR	3
19	9812288	1/2" X 1 1/4" CARR BOLT (PL)	12
20	9812378	3/8" X 3/4" SQ HD SET SCREW SER	8

# LIGHT KIT - 16124

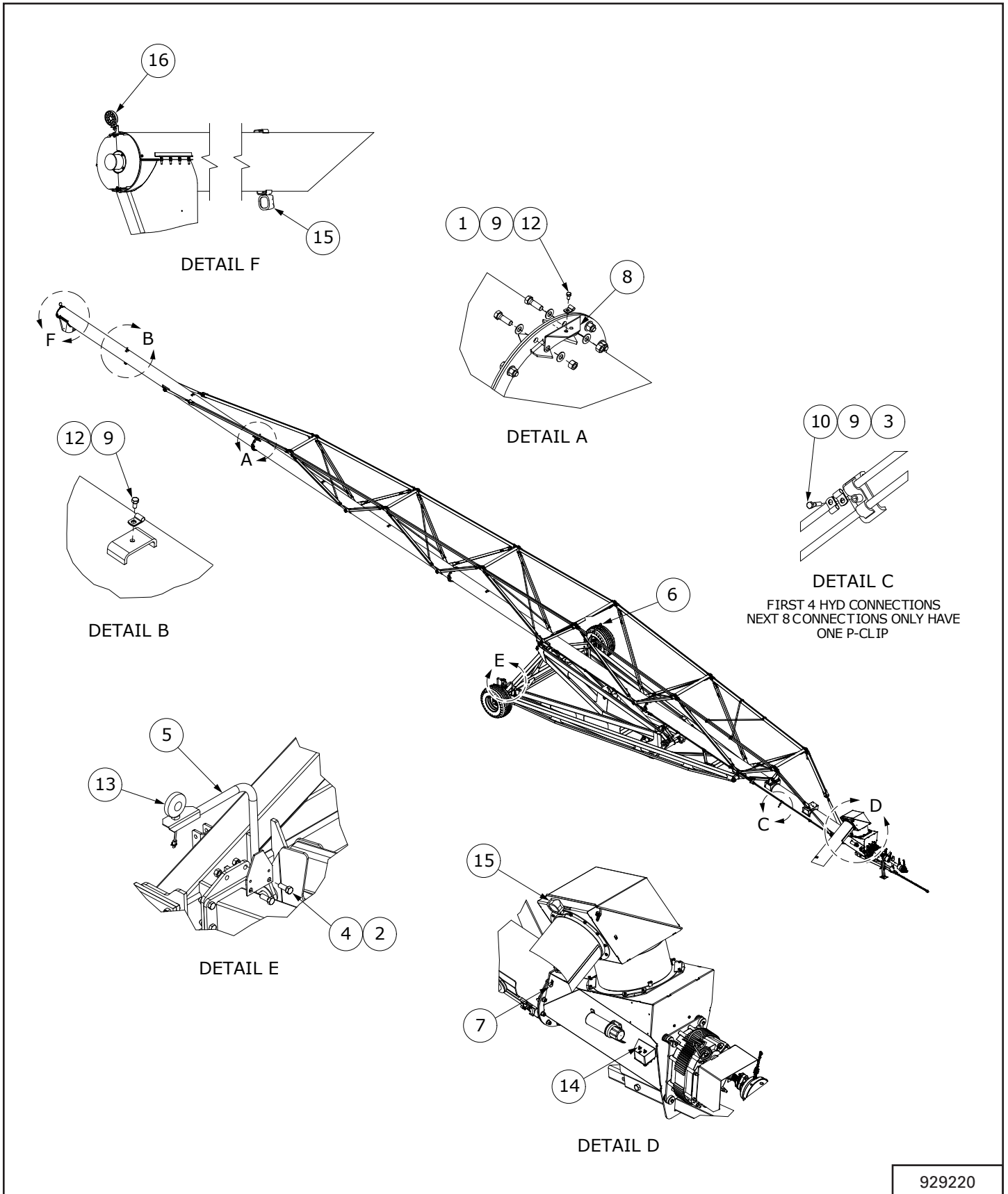

929220

ITEM	PART NUMBER	DESCRIPTION	QTY.
1	812362	5/16" LOCK NUT (PL)	2
2	812365	3/4" LOCK NUT (PL)	4
3	81553	5/16" X 1 1/2" HEX BOLT (PL)	12
4	84467	3/4" X 2" HEX BOLT (PL)	4
5	909226	BLINKER MOUNT WELDT - RH	1
6	909227	BLINKER MOUNT WELDMENT - LH	1
7	913193	P-CLIP 0.75	1
8	914882	BRKT-CABLE MOUNT BS16104	2
9	919485	SUPPORT CLAMP-3/8 DIA	24
10	927998	LIGHT KIT BUSHING	12
11	929222	BS16124 LIGHT KIT	1
12	BU500397-6	HEX BOLT 5/16 X 5/8" (PL)	8
13	909420	LIGHT-AMBER	2
14	909422	SWITCH-WEATHER PROOF	2
15	928875	WORK LIGHT-LED	2
16	929235	LIGHT-RED	1
*	909414	HARNESS-BS MAIN	1
	909415	HARNESS-BS INPUTTUBE LIGHT	1
	909418	HARNESS-BS AMBER LIGHT EXT	1
	909419	HARNESS-AMBER LIGHT SHORT EXTENSION	2
	909423	HARNESS-7 PIN RD TO 7 PIN FLAT ADAPTOR	1
	929233	HARNESS-BS16124 TOPTUBE LIGHT [127']	1
	929234	HARNESS-BS16124 AMBER LIGHTS [53']	1

\* HARNESSES NOT SHOWN

# HYDRAULIC HOPPER MOVER / WINCH - 1684, 16104

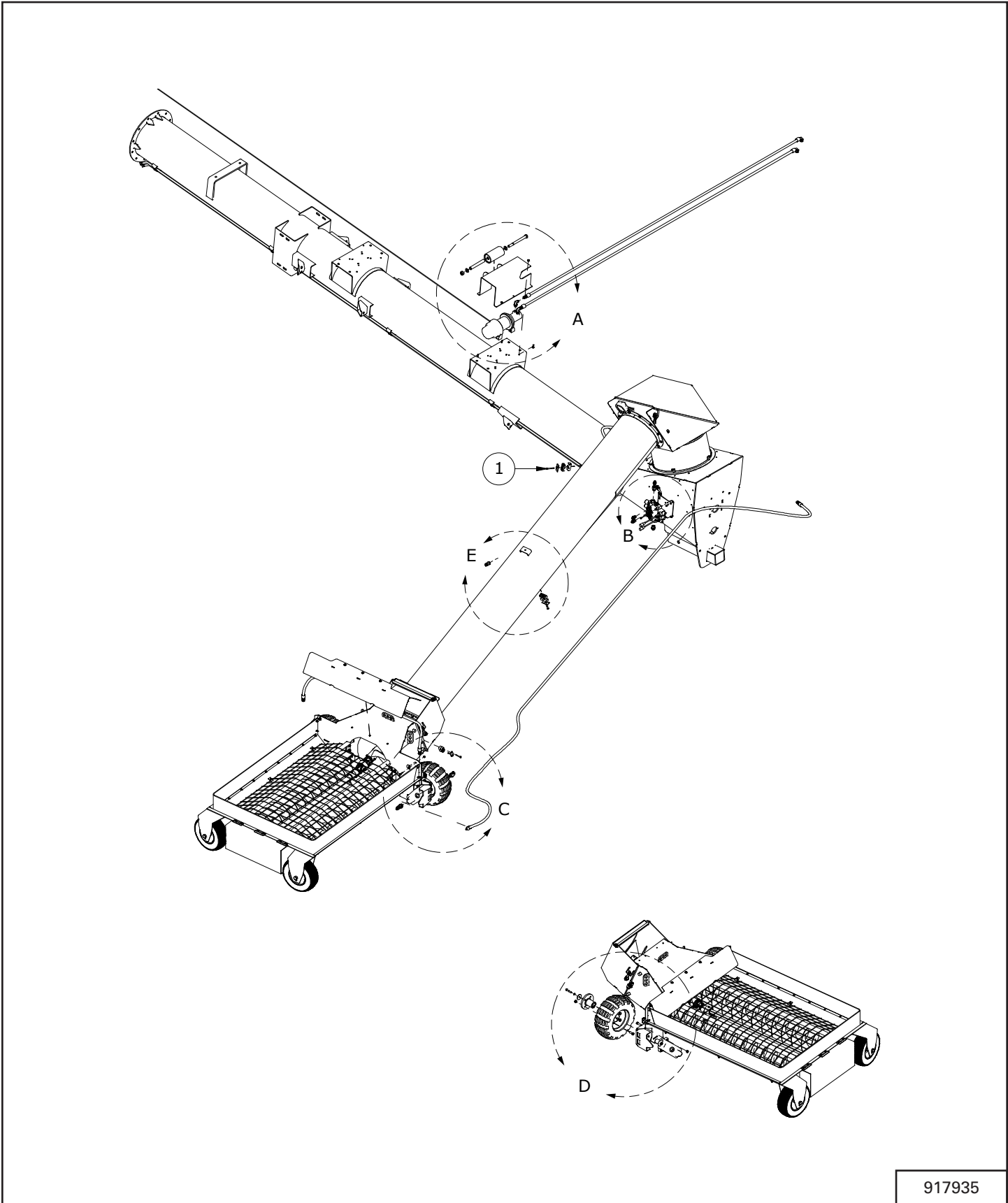

917935

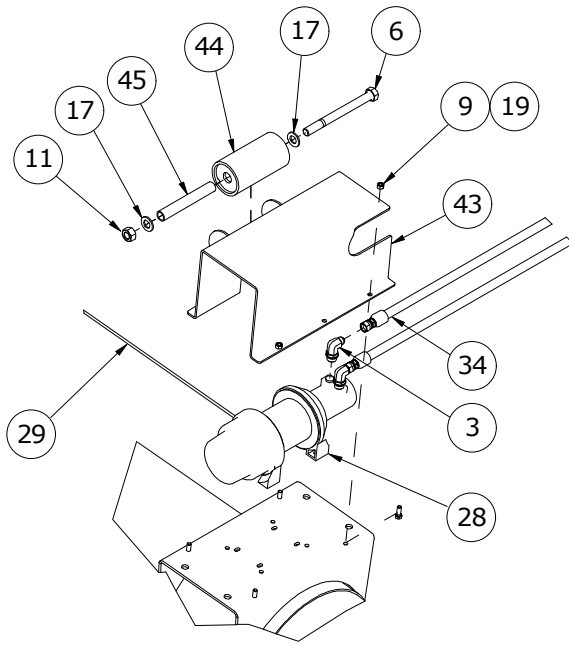

DETAIL A

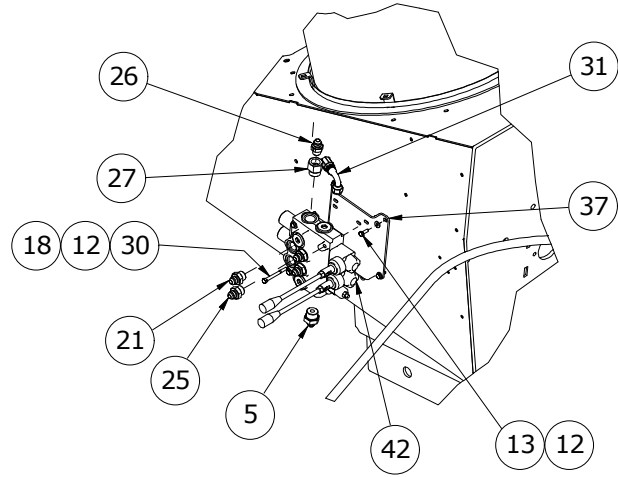

DETAIL B

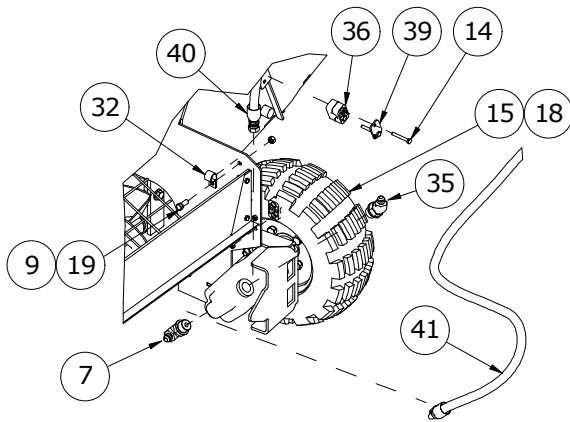

DETAIL C

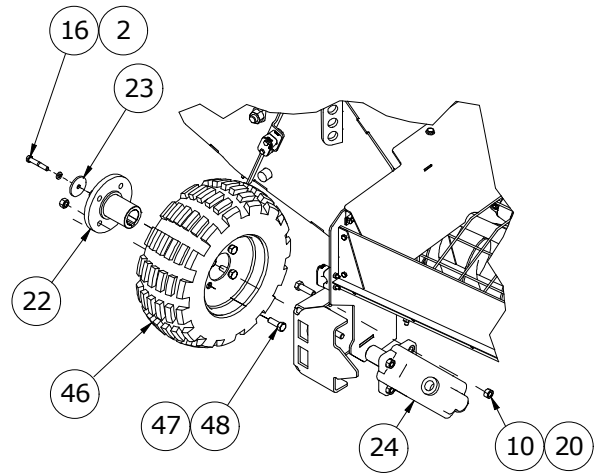

DETAIL D

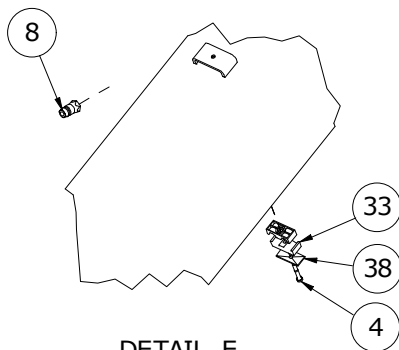

DETAIL E

ITEM	PART NUMBER	DESCRIPTION	QTY.
1	810761	5/16" X 2 1/2" HEX BOLT (PL)	1
2	810958	3/8" X 2 1/4" HEX BOLT (PL)	2
3	811416	ELBOW-10 MORB X -8 MJIC, 90 DEG	2
4	811688	BOLT-5/16" X 2 1/4" (PL) GR.5	3
5	811748	ADAPTOR -12 MORB X -8 MJIC	1
6	811908	BOLT HEX 0.750NC X 8.50 GR5PL	1
7	811960	ELBOW -12 MORB X -8 MJIC 90	2
8	812208	NIPPLE 1/2" BODY 1/2"-14 NPTF QUICK CONNECT	2
9	812363	3/8" LOCK NUT (PL)	6
10	812364	1/2" LOCK NUT (PL)	8
11	812365	3/4" LOCK NUT (PL)	1
12	812624	1/4" FLAT WASHER PL	7
13	81525	1/4" X 3/4" HEX BOLT (PL)	4
14	81531	BOLT HEX 0.25NC X 2.00 GR5 PL	8
15	81532	1/4" X 2 1/4" HEX BOLT GR5 (PL)	4
16	81593	3/8" LOCKWASHER (PL)	2
17	84050	3/4" S.A.E. FLAT WASHER (PL)	2
18	84498	1/4" LOCK NUT (PL)	7
19	86170	3/8" X 1" HEX BOLT GR.5 (PL)	6
20	87553	1/2" X 1.75" HEX BOLT UNC GR5 (PL)	8
21	886897	ADAPTOR STR 7/8MORB X 3/4MJIC S	2
22	909179	HUB WELDT	2
23	909180L	FLAT WASHER 7GA X 13/32"ID X 2"OD	2
24	909193	HYDRAULIC MOTOR 169-0093-001	2
25	909460	ADAPTOR STR 7/8MORB X 3/4MJIC R.0625	2
26	909935	ADAPTOR CHECK VALVE (#8 MORB - #8 MJIC)	1
27	909936	ADAPTER-12MORB X -8FORB	1
28	910483	WARN HYDRAULIC WINCH	1
29	910508	WINCH CABLE ASSEMBLY (1/4")	1
30	910523	1/4" X 2 3/4" HEX BOLT (PL)	3
31	912250	HOSE 1/2" X 140" MNPT X 3/4" SWFJIC 90	2
32	913193	P-CLIP 0.75	2
33	914640	HOSE CLAMP-TWIN 0.787 DIA	4
34	914931	HOSE-8 X -8FJIC X -8FJIC 90 DEG	2
35	916912	ADAPTOR-08 MJIC X -12 MORB 45 DEG	2
36	916917	CLAMP-SINGLE 0.79	6
37	916959	BRKT-VALVE MOUNT	1
38	917014	COVER-TWIN CLAMP 3D	4
39	917015	COVER-SINGLE CLAMP 3	6
40	917021	HOSE-08 X -08 SWFJIC X -08 SWFJIC	1
41	917022	HOSE-08 X -08 SWFJIC X -08 SWFJIC 90	2

ITEM	PART NUMBER	DESCRIPTION	QTY.
42	917223	ASSEMBLY-VALVE W/HANDLEVERS	1
43	932132	WELDT-WINCH GUARD	1
44	932146	WELDT-ROLLER	1
45	932408	TUBE-ROLLER CORE	1
46	960800	TIRE W/WHEEL 16/650X8	2
47	967105	WHEEL NUT 1/2" (STEEL)	8
48	968404	WHEEL BOLT 1/2" X 1 1/4" (PL)	8

# HYDRAULIC HOPPER MOVER / WINCH - 16124

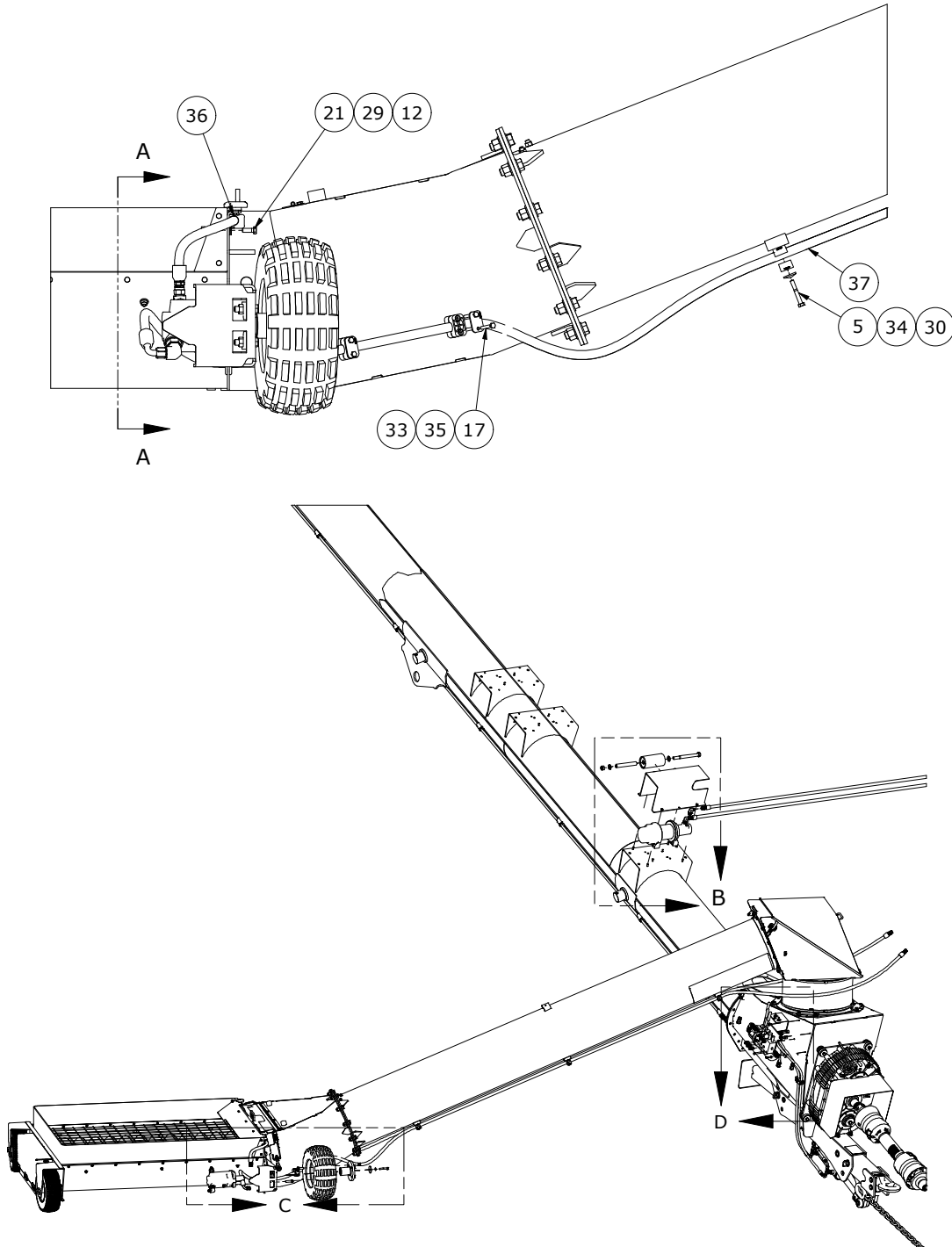

933335

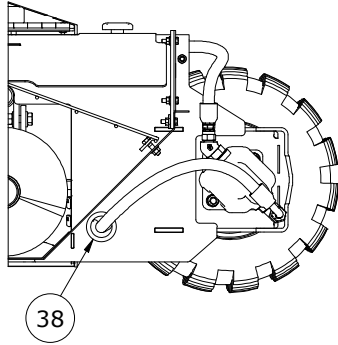

SECTION A-A

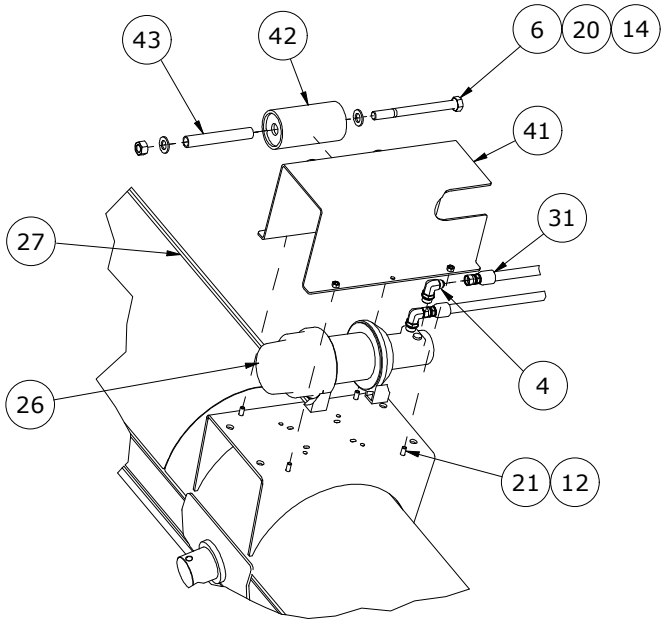

DETAIL B

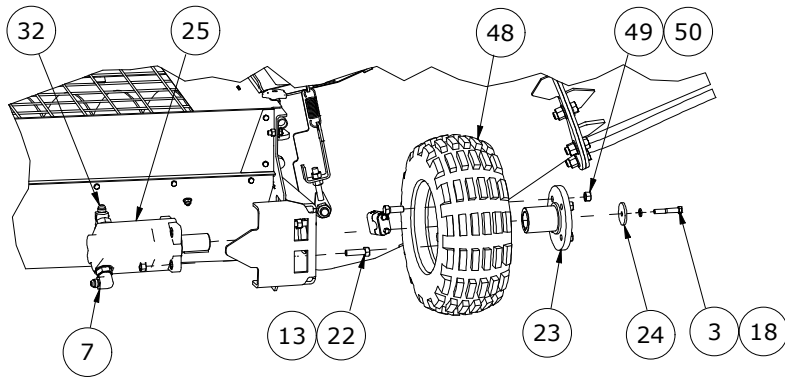

DETAIL C

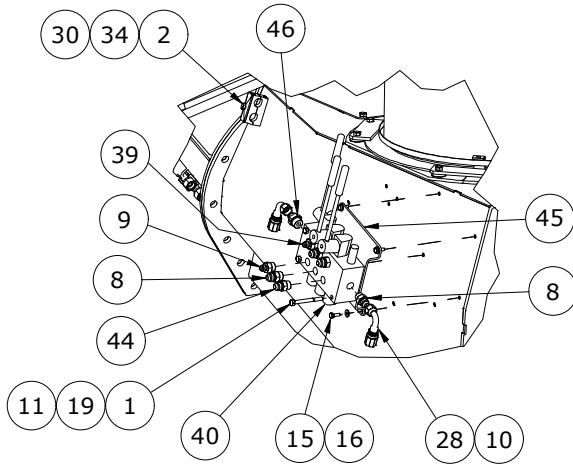

DETAIL D

ITEM	PART NUMBER	DESCRIPTION	QTY.
1	810582	5/16" X 3" HEX BOLT (PL)	3
2	810761	5/16" X 2 1/2" HEX BOLT (PL)	1
3	810958	3/8" X 2 1/4" HEX BOLT (PL)	2
4	811416	ELBOW-10 MORB X -8 MJIC, 90 DEG	2
5	811688	BOLT-5/16" X 2 1/4" (PL) GR.5	3
6	811908	BOLT HEX 0.750NC X 8.50 GR5PL	1
7	811960	ELBOW -12 MORB X -8 MJIC 90	2
8	812080	ADAPTOR STR 3/4MORB X 3/4MJIC	3
9	812107	ADAPTOR STR 3/4MORB X 9/16MJI	1
10	812208	NIPPLE 1/2" BODY 1/2"-14 NPTF QUICK CONNECT	2
11	812362	5/16" LOCK NUT (PL)	3
12	812363	3/8" LOCK NUT (PL)	6
13	812364	1/2" LOCK NUT (PL)	8
14	812365	3/4" LOCK NUT (PL)	1
15	812624	1/4" FLAT WASHER PL	4
16	81525	1/4" X 3/4" HEX BOLT (PL)	4
17	81531	BOLT HEX 0.25NC X 2.00 GR5 PL	8
18	81593	3/8" LOCK WASHER (PL)	2
19	84039	WASHER - 3/8" SAE FLAT (PL)	3
20	84050	3/4" S.A.E. FLAT WASHER (PL)	2
21	86170	3/8" X 1" HEX BOLT GR.5 (PL)	6
22	87553	1/2" X 1.75" HEX BOLT UNC GR5 (PL)	8
23	909179	HUB WELDT	2
24	909180L	FLAT WASHER 7GA X 13/32"ID X 2"OD	2
25	909193	HYDRAULIC MOTOR 169-0093-001	2
26	910483	WARN HYDRAULIC WINCH	1
27	910508	WINCH CABLE ASSEMBLY (1/4")	1
28	912250	HOSE 1/2" X 140" MNPT X 3/4" SWFJIC 90	2
29	913193	P-CLIP 0.75	2
30	914640	HOSE CLAMP-TWIN 0.787 DIA	4
31	914931	HOSE-8 X -8FJIC X -8FJIC 90 DEG	2
32	916912	ADAPTOR-08 MJIC X -12 MORB 45 DEG	2
33	916917	CLAMP-SINGLE 0.79	4
34	917014	COVER-TWIN CLAMP 3D	4
35	917015	COVER-SINGLE CLAMP 3	4
36	917021	HOSE-8 X -8 FJIC X -8 FJIC	1
37	917022	HOSE-8 X -8 FJIC X -8 FJIC 90	2
38	929764	RUBBER GROMMET- 1.50" ID	2
39	930393	-6MJIC X -8MORB X 0.06ORF	1
40	932080	Q45 3 SPOOL HYDRAULIC VALVE	1
41	932132	WELDT-WINCH GUARD	1

ITEM	PART NUMBER	DESCRIPTION	QTY.
42	932146	WELDT-ROLLER	1
43	932408	TUBE-ROLLER CORE	1
44	933064	ADPTR -8 MORB X -8 MJIC R.0625	2
45	933332	BRKT-VALVE MOUNT	1
46	933334	ADPTR CHECK VALVE -10 MORB X -8 MJIC	1
48	960800	TIRE W/WHEEL 16/650X8	2
49	967105	WHEEL NUT 1/2" (STEEL)	8
50	968404	WHEEL BOLT 1/2" X 1 1/4" (PL)	8

# ELECTRIC HOPPER MOVER / WINCH - 16124

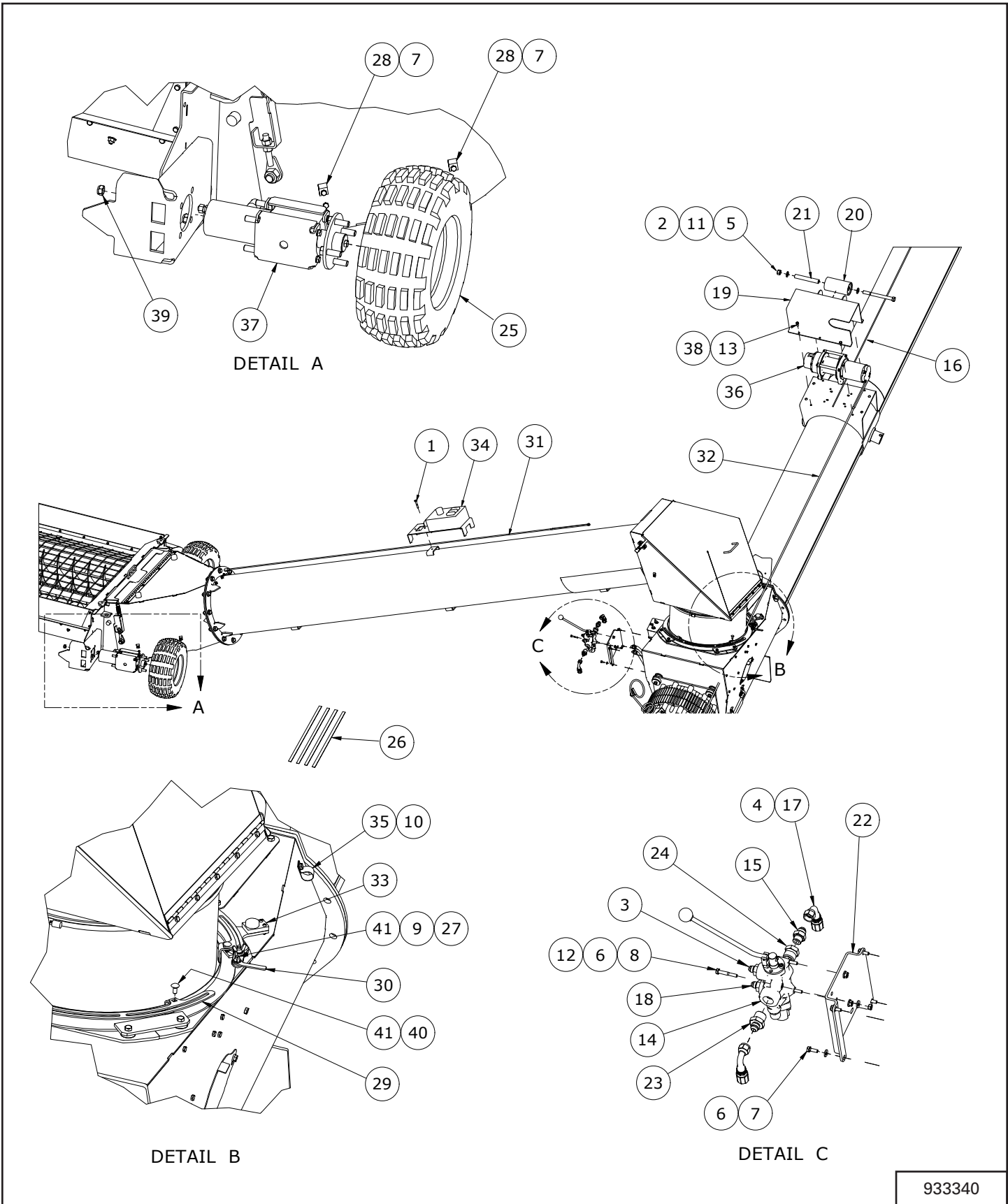

ITEM	PART NUMBER	DESCRIPTION	QTY.
1	810640	5/16" X 2" HEX BOLT (PL)	1
2	811908	BOLT HEX 0.750NC X 8.50 GR5PL	1
3	812107	ADAPTOR STR 3/4MORB X 9/16MJI	1
4	812208	NIPPLE 1/2" BODY 1/2"-14 NPTF QUICK CONNECT	2
5	812365	3/4" LOCK NUT (PL)	1
6	812624	1/4" FLAT WASHER PL	7
7	81525	1/4" X 3/4" HEX BOLT (PL)	12
8	81530	1/4" X 1 3/4" HEX BOLT GR5 (PL)	3
9	81546	5/16" FLAT WASHER (PL)	4
10	81549	5/16" X 3/4" HEX BOLT (PL)	1
11	84050	3/4" S.A.E. FLAT WASHER (PL)	2
12	84498	1/4" LOCK NUT (PL)	3
13	86170	3/8" X 1" HEX BOLT GR.5 (PL)	4
14	908995	4 WAY DIRECTIONAL CONTROL VALVE (AO)	1
15	909935	ADAPTOR CHECK VALVE (#8 MORB - #8 MJIC)	1
16	910508	WINCH CABLE ASSEMBLY (1/4")	1
17	912250	HOSE 1/2" X 140" MNPT X 3/4" SWFJIC 90	2
18	930393	-6MJIC X -8MORB X 0.06ORF	1
19	932132	WELDT-WINCH GUARD	1
20	932146	WELDT-ROLLER	1
21	932408	TUBE-ROLLER CORE	1
22	933332	BRKT-VALVE MOUNT	1
23	933337	ADPTR -8 MJIC X -12 MPT	1
24	937900	ADPTR -8 FORB -12 MPT	1
25	960800	TIRE W/WHEEL 16/650X8	2
26	967184	14 1/2" STRAP	4
27	968601	5/16" WING NUT	4
28	SZ000566	5/16X0.406 HOLE VINYL DIP CLAMP	4
29	SZ000957	16" MRD PROXIMITY RAIL	2
30	SZ000968	PROXIMITY INDICATOR	2
31	SZ000998	HARNESS, ELEC MVR, WINCH	1
32	SZ000999	WINCH HARNESS	1
33	SZ001020	10/13" PROX SENSOR MNT ASMBLY	1
34	SZ001044	ASSY-16" CTRL BOX MNT	1
35	SZ001055	1"X.406 HOLE VINYL DIP CLAMP	1
36	SZ001195	WARN DC2000MF ELEC HOIST	1
37	SZ001230	16" ELEC MTR ASSEMBLY	2
38	SZ125030	NUT LCK 3/8-16UNC NYLOCK	4
39	SZ125032	NUT LCK, 1/2" -13UNC NYLOCK	8
40	SZ125035	NUT LCK, 5/16" -18UNC, NYLOCK G5	4
41	SZ126006	BOLT CARRIAGE 5/16-18 UNC 3/4	8

# Farm King



## SPECIFICATIONS

ELECTRICAL DIAGRAM.....	145
1684, 16104 Models.....	145
16124 Models.....	146
DIMENSIONS.....	148
1684, 16104 Models.....	148
16124 Models.....	150
PERFORMANCE.....	152
HARDWARE TORQUE VALUES.....	153
Metric Chart.....	153
Imperial Chart.....	154
HYDRAULIC CONNECTION SPECIFICATIONS.....	155
O-Ring Fitting (Straight Thread).....	155
O-Ring Face Seal Connection.....	155
Flare Fitting.....	155
Port Seal (O-Ring Boss) Fitting.....	155
Tubelines And Hoses.....	155

# Farm King



# ELECTRICAL DIAGRAM

1684, 16104 Models

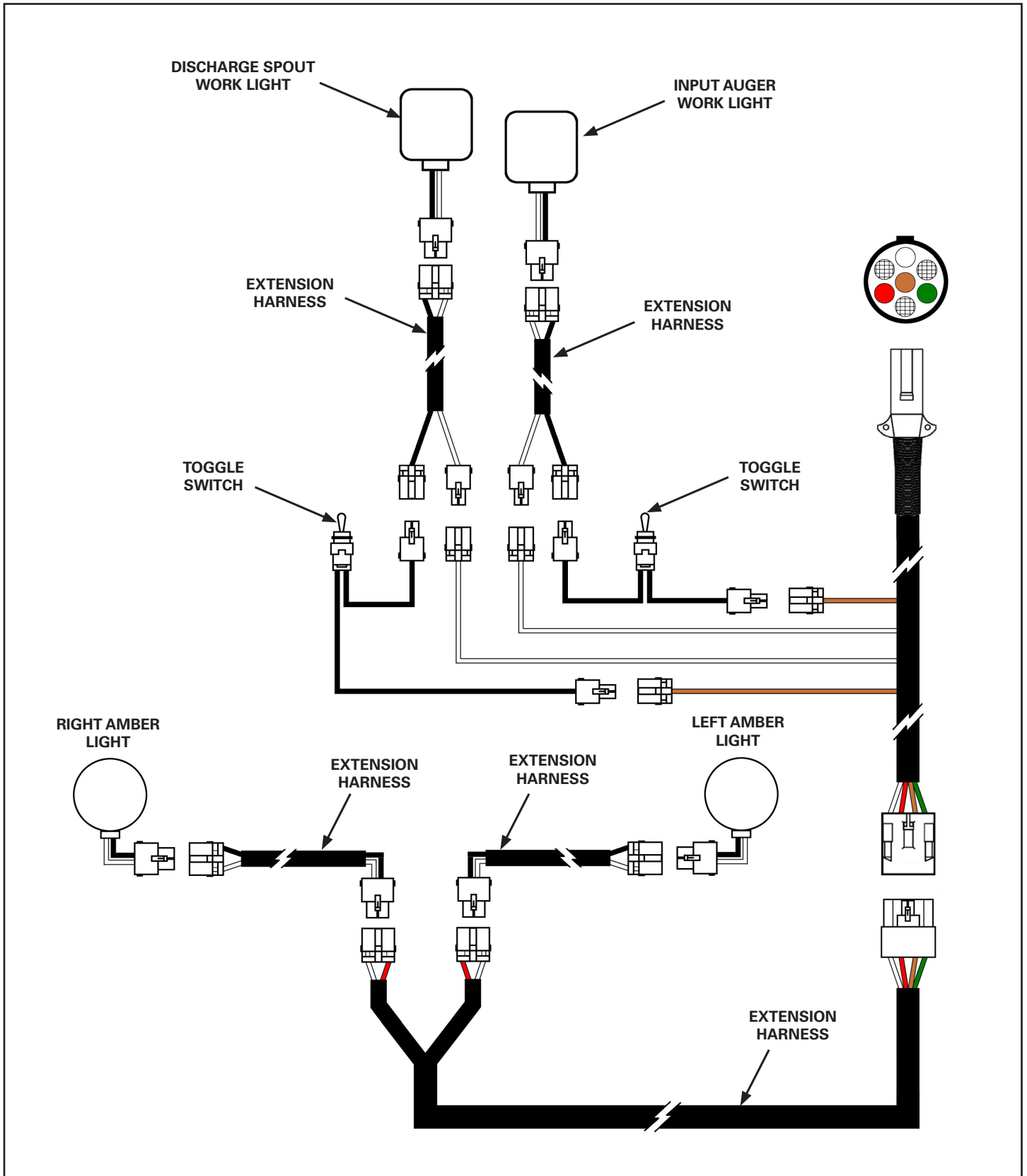

**16124 Models**

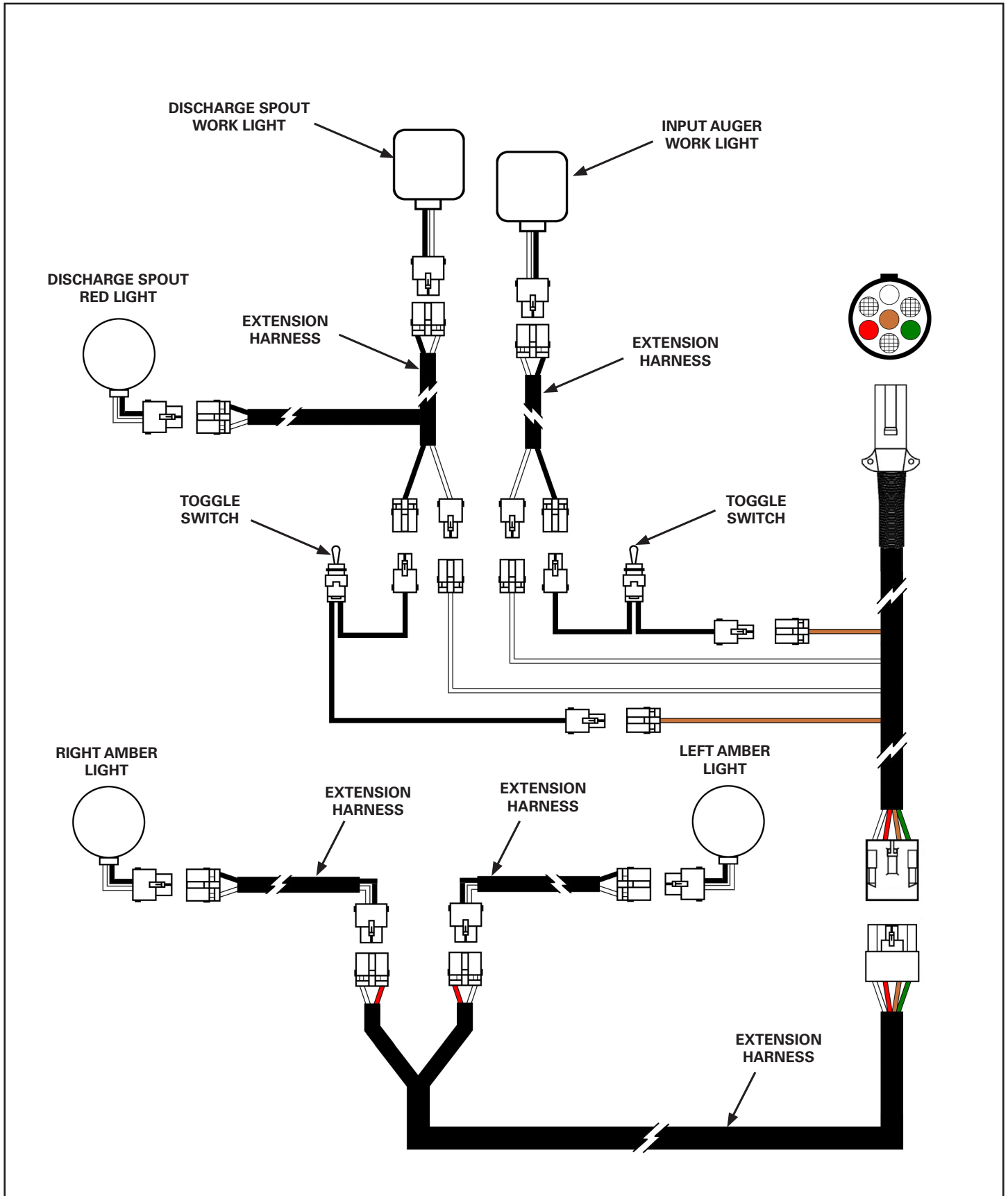

# Farm King



## DIMENSIONS

### 1684, 16104 Models

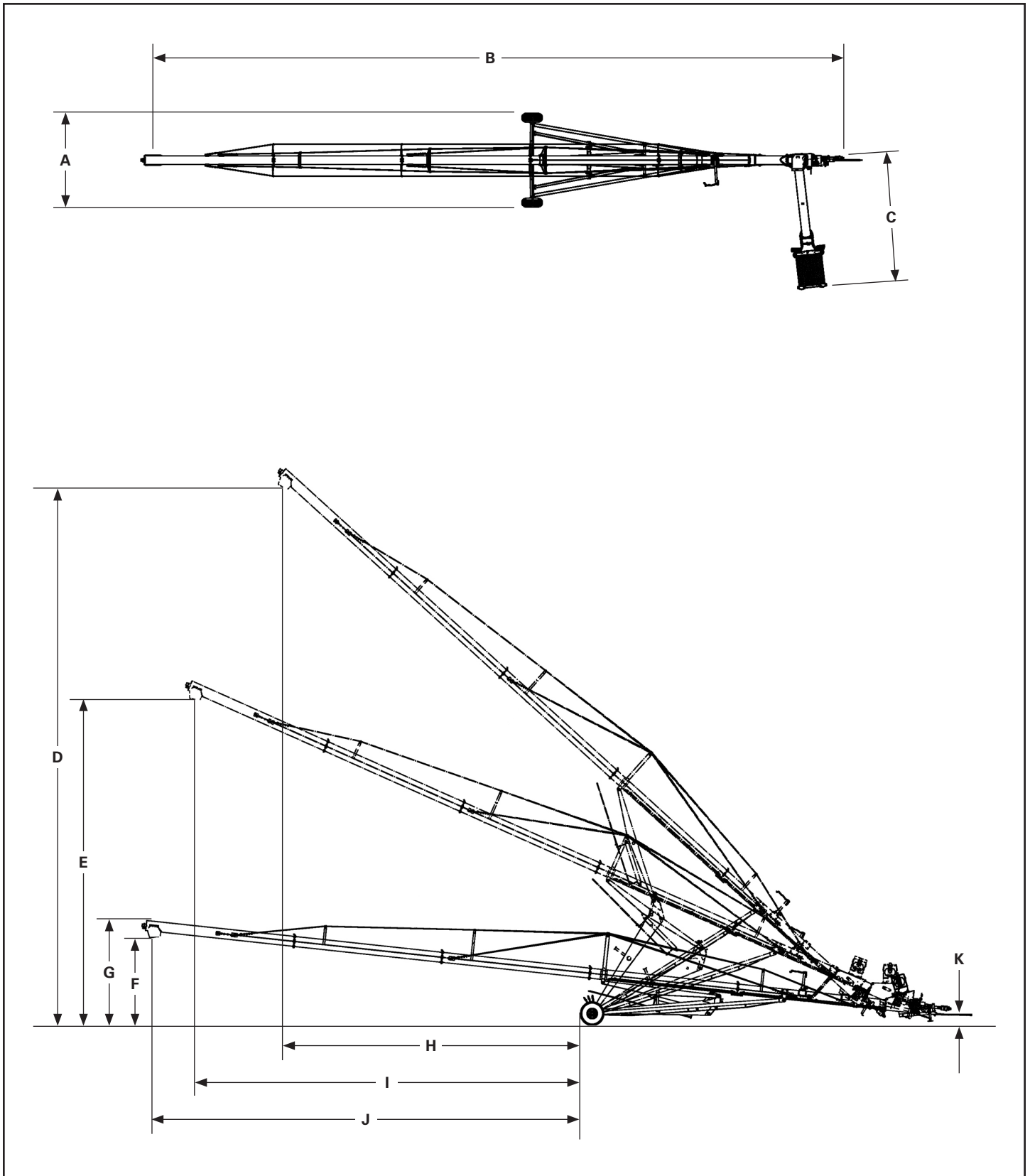

DESCRIPTION	DIMENSION	
	1684	16104
Overall Width (A)	163 in.	173 in.
Overall Length (B)	1019 in.	1266 in.
Input Auger / Hopper Length (C)	235 in.	235 in.
Discharge Spout Height @ 42° Angle (D)	679 in.	857 in.
Discharge Spout Height @ 24° Angle (E)	424 in.	520 in.
Discharge Spout Height @ 6° Angle (F)	135 in.	141 in.
Transport Height (G)	163 in.	168 in.
Discharge Spout To Wheels @ 42° Angle (H)	390 in.	481 in.
Discharge Spout To Wheels @ 24° Angle (I)	481 in.	623 in.
Discharge Spout To Wheels @ 6° Angle (J)	525 in.	687 in.
Hitch Height (K)	18 in.	18 in.

**16124 Models**

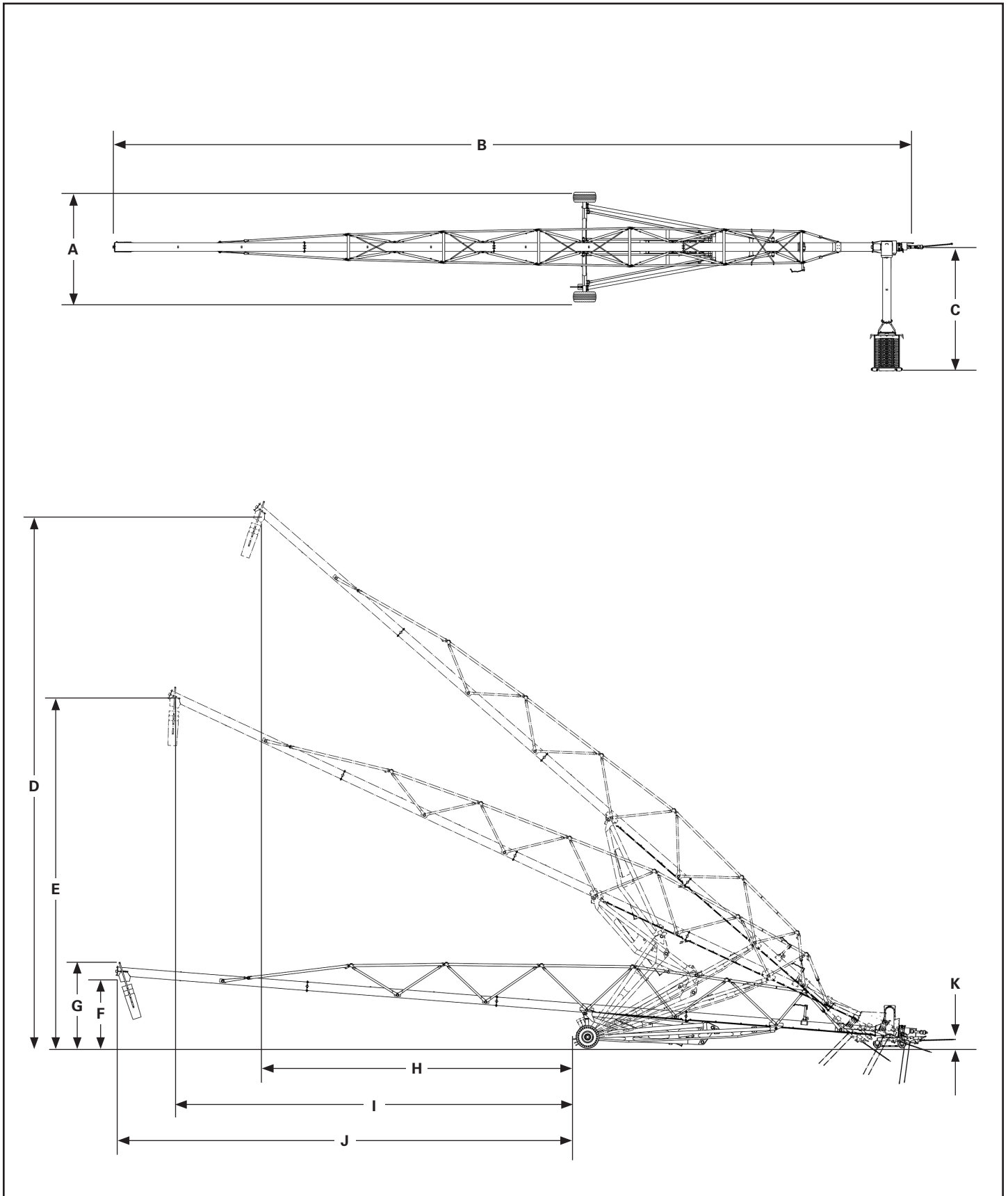

DESCRIPTION	DIMENSION
	16124
Overall Width (A)	207 in.
Overall Length (B)	1511 in.
Input Auger / Hopper Length (C)	235 in.
Discharge Spout Height @ 42° Angle (D)	998 in.
Discharge Spout Height @ 24° Angle (E)	644 in.
Discharge Spout Height @ 6° Angle (F)	125 in.
Transport Height (G)	152 in.
Discharge Spout To Wheels @ 42° Angle (H)	635 in.
Discharge Spout To Wheels @ 24° Angle (I)	793 in.
Discharge Spout To Wheels @ 6° Angle (J)	885 in.
Hitch Height (K)	20 in.

**PERFORMANCE**

DESCRIPTION	PERFORMANCE		
	1684	16104	16124
Maximum PTO Speed	1000 RPM		
Main Auger Tubes	16 in. Dia.		
Main Auger Size	15.25 in. OD		
Hopper	16 in. Multi Flighting		
Hopper Intake Size	55.17 in. x 45.85 in.	55.17 in. x 45.85 in.	55.17 in. x 45.85 in.
Hopper Drive Chain	80H Roller Chain	80H Roller Chain	H60 Roller Chain
Hitch Tongue Weight (Down Position)	2,300 lb.	2,460 lb.	3,810 lb.
Total Weight	11,000 lb.	13,500 lb.	23,010 lb.
Hubs And Wheels	6 Bolt Hubs / 12.5 L-15 FI	8 Bolt Hubs / 16.5 L x 16.1 x 10 Ply	10 Bolt Hubs / 480/55R22.5
Winch	Hydraulic / Optional Electrical Winch		
M2000 Helical Gearbox	75W - 90 Synthetic Gear Oil		
4168 Lower Gearbox	75W - 90 Synthetic Gear Oil		
4168 Upper Gearbox	75W - 90 Synthetic Gear Oil		

## HARDWARE TORQUE VALUES

### Metric Chart

**NOTE: Do not use the values listed in the charts if a different torque value or tightening procedure is specified in this manual for a specific application. Torque values listed are for general use only.**

Use the following charts to determine the correct torque when checking, adjusting or replacing hardware. **Torque values are listed in newton-meters (inch\* or foot pounds) for normal assembly applications.**

Nominal Size	Class 5.8		Class 8.8		Class 10.9		Lock nuts
	Unplated	Plated W / ZnCr	Unplated	Plated W / ZnCr	Unplated	Plated W / ZnCr	CL.8 w/ CL. 8.8 Bolt
M4	1.7 (15*)	2.2 (19*)	2.6 (23*)	3.4 (30*)	3.7 (33*)	4.8 (42*)	1.8 (16*)
M6	5.8 (51*)	7.6 (67*)	8.9 (79*)	12 (102*)	13 (115*)	17 (150*)	6.3 (56*)
M8	14 (124*)	18 (159*)	22 (195*)	28 (248*)	31 (274*)	40 (354*)	15 (133*)
M10	28 (21)	36 (27)	43 (32)	56 (41)	61 (45)	79 (58)	30 (22)
M12	49 (36)	63 (46)	75 (55)	97 (72)	107 (79)	138 (102)	53 (39)
M16	121 (89)	158 (117)	186 (137)	240 (177)	266 (196)	344 (254)	131 (97)
M20	237 (175)	307 (226)	375 (277)	485 (358)	519 (383)	671 (495)	265 (195)
M24	411 (303)	531 (392)	648 (478)	839 (619)	897 (662)	1160 (855)	458 (338)

**NOTE: Torque values shown with \* are inch pounds.**

### Identification of Hex Cap Screws and Carriage Bolts - Classes 5 and up

MANUFACTURER'S IDENTIFICATION

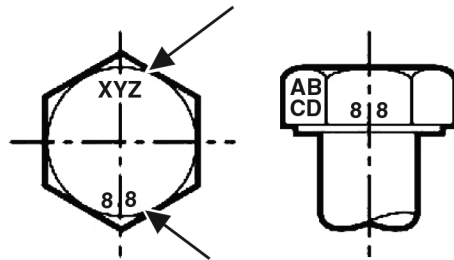

PROPERTY CLASS

### Identification of Hex Nuts and Lock Nuts - Classes 5 and up

MANUFACTURER'S IDENTIFICATION

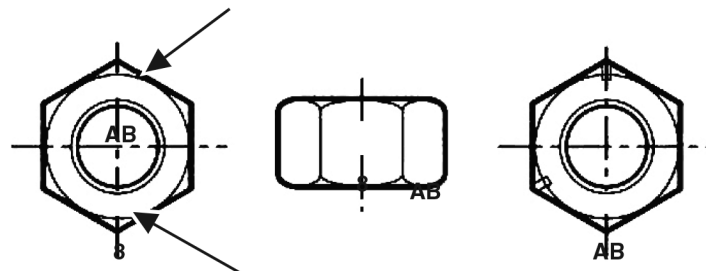

PROPERTY CLASS

### Imperial Chart

**NOTE: Do not use the values listed in the charts if a different torque value or tightening procedure is specified in this manual for a specific application. Torque values listed are for general use only.**

Use the following charts to determine the correct torque when checking, adjusting or replacing hardware. **Torque values are listed in newton-meters (inch\* or foot pounds) for normal assembly applications.**

Nominal Size	SAE Grade 5		SAE Grade 8		LOCK NUTS			
	Unplated or Plated Silver	Plated W / ZnCr Gold	Unplated or Plated Silver	Plated W / ZnCr Gold	Unplated or Plated Silver	Plated W / ZnCr Gold	Grade W / Gr. 5 Bolt	Grade W / Gr. 8 Bolt
1/4	6.2 (55*)	8.1 (72*)	9.7 (86*)	12.6 (112*)	13.6 (121*)	17.7 (157*)	6.9 (61*)	9.8 (86*)
5/16	13 (115*)	17 (149*)	20 (178*)	26 (229*)	28 (250*)	37 (324*)	14 (125*)	20 (176*)
3/8	23 (17)	30 (22)	35 (26)	46 (34)	50 (37)	65 (48)	26 (19)	35 (26)
7/16	37 (27)	47 (35)	57 (42)	73 (54)	80 (59)	104 (77)	41 (30)	57 (42)
1/2	57 (42)	73 (54)	87 (64)	113 (83)	123 (91)	159 (117)	61 (45)	88 (64)
9/16	81 (60)	104 (77)	125 (92)	163 (120)	176 (130)	229 (169)	88 (65)	125 (92)
5/8	112 (83)	145 (107)	174 (128)	224 (165)	244 (180)	316 (233)	122 (90)	172 (127)
3/4	198 (146)	256 (189)	306 (226)	397 (293)	432 (319)	560 (413)	217 (160)	306 (226)
7/8	193 (142)	248 (183)	495 (365)	641 (473)	698 (515)	904 (667)	350 (258)	494 (364)
1	289 (213)	373 (275)	742 (547)	960 (708)	1048 (773)	1356 (1000)	523 (386)	739 (545)

**NOTE: Torque values shown with \* are inch pounds.**

### Identification of Hex Cap Screws and Carriage Bolts

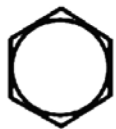

SAE GRADE 2 BOLTS



SAE GRADE 5 BOLTS



SAE GRADE 8 BOLTS



SAE GRADE 2 NUTS



SAE GRADE 2 NUTS



SAE GRADE 2 NUTS

### Identification of Hex Nuts and Lock Nuts

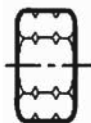

Grade A - No Notches

Grade B - One Circumferential Notch

Grade C - One Circumferential Notches

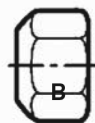

Grade A - No Mark

Grade B - Letter B

Grade C - Letter C

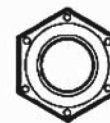

Grade A - No Marks

Grade B - Three Marks

Grade C - Six Marks

(Marks not always located at corners)

## HYDRAULIC CONNECTION SPECIFICATIONS

### O-Ring Fitting (Straight Thread)

Lubricate the O-ring before installing the fitting. Loosen the jam nut and install the fitting. Tighten the jam nut until the washer is tight against the surface.

### O-Ring Face Seal Connection

O-ring Face Seal Tightening Torque		
Tubeline O.D.	Thread Size	N•m (ft-lb)
1/4"	9/16" - 18	13 (18)
3/8"	11/16" - 16	22 (30)
1/2"	13/16" - 16	40 (54)
5/8"	1" - 14	60 (81)
3/4"	1-3/16" - 12	84 (114)
7/8"	1-3/16" - 12	98 (133)
1"	1-7/16" - 12	118 (160)
1-1/4"	1-11/16" - 12	154 (209)
1-1/2"	2" - 12	163 (221)

When the fitting is tightened, you can feel when the fitting is tight to eliminate leakage caused by under or over torqued fittings. Use petroleum jelly to hold the O-ring in position until the fittings are assembled.

### Flare Fitting

Flare Fitting Tightening Torque		
Tubeline O.D.	Thread Size	N • m (ft-lb)
1/4"	7/16" - 20	13 (18)
5/16"	1/2" - 20	17 (23)
3/8"	9/16" - 18	22 (30)
1/2"	3/4" - 16	40 (54)
5/8"	7/8" - 14	60 (81)
3/4"	1-1/16" - 12	84 (114)
7/8"	1-3/16" - 12	98 (133)
1"	1-5/16" - 12	118 (160)
1-1/4"	1-5/8" - 12	154 (209)
1-1/2"	1-7/8" - 12	163 (221)
2"	2-1/2" - 12	252 (342)

Tighten until the nut makes contact with the seat. Use the chart [Figure 57] to find the correct tightness needed.

### Port Seal (O-Ring Boss) Fitting

Port Seal And O-ring Boss Tightening Torque		
Tubeline O.D.	Thread Size	N•m (ft-lb)
1/4"	7/16" - 20	13 (18)
3/8"	9/16" - 18	22 (30)
1/2"	3/4" - 16	40 (54)
5/8"	7/8" - 14	60 (81)
3/4"	1-1/16" - 12	84 (114)
7/8"	1-3/16" - 12	98 (133)
1"	1-5/16" - 12	118 (160)
1-1/8"	1-7/16" - 12	154 (209)
1-1/4"	1-5/8" - 12	163 (221)

**Note:** Port seal and nut, washer and O-ring (O-ring Boss) fittings use the same tightening torque valve chart [Figure 58].

If a torque wrench cannot be used, use the following method.

Tighten the nut until it just makes metal to metal contact, you can feel the resistance.

Tighten the nut with a wrench no more than one hex flat maximum.

Do not over tighten the port seal fitting.

**Note:** If a torque wrench cannot be used, use the hex flat tightening method as an approximate guideline.

**Note:** Port seal fittings are not recommended in all applications. Use O-ring boss fittings in these applications.

### Tubelines And Hoses

Replace any tube lines that are bent or flattened. They will restrict flow, which will slow hydraulic action and cause heat.

Replace hoses which show signs of wear, damage or weather cracked rubber.

Always use two wrenches when loosening and tightening hose or tubeline fittings.

# Farm King



## **WARRANTY**

FARM KING BASE LIMITED WARRANTY.....	159
Repair Parts Limited Warranty.....	159
What Is Not Covered.....	159
Authorized Dealer And Labor Costs.....	159
Warranty Requirements.....	160

# Farm King



## **FARM KING BASE LIMITED WARRANTY**

Farm King provides this warranty only to original retail purchasers of its products. Farm King warrants to such purchasers that all Farm King manufactured parts and components used and serviced as provided for in the Operator's Manual shall be free from defects in materials and workmanship for a period following delivery to the original retail purchaser of two (2) years. This limited warranty applies only to those parts and components manufactured by Farm King. Parts and components manufactured by others are subject to their manufacturer's warranties, if any.

Farm King will fulfill this limited warranty by, at its option, repairing or replacing any covered part that is defective or is the result of improper workmanship, provided that the part is returned to Farm King within thirty (30) days of the date that such defect or improper workmanship is, or should have been, discovered. Parts must be returned through the selling representative and the buyer must prepay transportation charges.

Farm King will not be responsible for repairs or replacements that are necessitated, in whole or part, by the use of parts not manufactured by or obtained from Farm King. Under no circumstances are component parts warranted against normal wear and tear. There is no warranty on product pump seals, product pump bearings, rubber product hoses, pressure gauges, or other components that require replacement as part of normal maintenance.

### **Repair Parts Limited Warranty**

Farm King warrants genuine Farm King replacement parts purchased after the expiration of the Farm King Limited Warranty, and used and serviced as provided for in the Operator's Manual, to be free from defects in materials or workmanship for a period of thirty (30) days from the invoice date for the parts. Farm King will fulfill this limited warranty by, at its option, repairing or replacing any covered part that is defective or is the result of improper workmanship, provided that the part is returned to Farm King within thirty (30) days of the date that such defect or improper workmanship is, or should have been, discovered. Such parts must be shipped to the Farm King factory at the purchaser's expense.

### **What Is Not Covered**

Under no circumstances does this limited warranty cover any components or parts that have been subject to the following: negligence; alteration or modification not approved by Farm King; misuse; improper storage; lack of reasonable and proper maintenance, service, or repair; normal wear; damage from failure to follow operating instructions; accident; and/or repairs that have been made with parts other than those manufactured, supplied, and or authorized by Farm King.

### **Authorized Dealer And Labor Costs**

Repairs eligible for labor under this limited warranty must be made by Farm King or an authorized Farm King dealer. Farm King retains the exclusive discretion to determine whether it will pay labor costs for warranty repairs or replacements, and the amount of such costs that it will pay and the time in which the repairs will be made. If Farm King determines that it will pay labor costs for warranty work, it will do so by issuing a credit to the dealer's or distributor's account. Farm King will not approve or pay invoices sent for repairs that Farm King has not previously approved. Warranty service does not extend the original term of this limited warranty. Payment of labor costs will only be considered on repairs made to manufactured parts and components that have been found defective during a period of one (1) year following delivery to the original retail purchaser.

## **Warranty Requirements**

To be covered by warranty, each new product must be registered with Farm King within thirty (30) days of delivery to original retail purchaser. If the customer decides to purchase replacement components before the warranty disposition of such components is determined, Farm King will bill the customer for such components and then credit the replacement invoice for those components later determined to be covered by this limited warranty. Any such replacement components that are determined not be covered by this limited warranty will be subject to the terms of the invoice and shall be paid for by the purchaser.

### **EXCLUSIVE EFFECT OF WARRANTY AND LIMITATION OF LIABILITY**

TO THE EXTENT PERMITTED BY LAW, FARM KING DISCLAIMS ANY WARRANTIES, REPRESENTATIONS, OR PROMISES, EXPRESS OR IMPLIED, AS TO THE QUALITY, PERFORMANCE, OR FREEDOM FROM DEFECT OF THE COMPONENTS AND PARTS COVERED BY THIS WARRANTY AND NOT SPECIFICALLY PROVIDED FOR HEREIN.

TO THE EXTENT PERMITTED BY LAW, FARM KING DISCLAIMS ANY IMPLIED WARRANTIES OF MERCHANTABILITY AND FITNESS FOR A PARTICULAR PURPOSE ON ITS PRODUCTS COVERED HEREIN, AND DISCLAIMS ANY RELIANCE BY THE PURCHASER ON FARM KING'S SKILL OR JUDGMENT TO SELECT OR FURNISH GOODS FOR ANY PARTICULAR PURPOSE. THE PURCHASER'S ONLY AND EXCLUSIVE REMEDIES IN CONNECTION WITH THE BREACH OR PERFORMANCE OF ANY WARRANTY ON FARM KING'S PRODUCTS ARE THOSE SET FORTH HEREIN. IN NO EVENT SHALL FARM KING BE LIABLE FOR INCIDENTAL OR CONSEQUENTIAL DAMAGES (INCLUDING, BY WAY OF EXAMPLE ONLY AND NOT LIMITATION, LOSS OF CROPS, LOSS OF PROFITS OR REVENUE, OTHER COMMERCIAL LOSSES, INCONVENIENCE, OR COST OF REPLACEMENT OF RENTAL EQUIPMENT). IN NO EVENT SHALL FARM KING'S CONTRACT OR WARRANTY LIABILITY EXCEED THE PURCHASE PRICE OF THE PRODUCT. (Note that some states do not allow limitations on how long an implied warranty lasts or the exclusion or limitation of incidental or consequential damages, so the above limitations and exclusion may not apply to you.) This warranty gives you specific legal rights and you may also have other rights, which vary from state to state.

Farm King neither assumes nor authorizes any person or entity, including its selling representatives, to assume any other obligations or liability in connections with the sale of covered equipment, or to make any other warranties, representations, or promises, express or implied, as to the quality, performance, or freedom from defect of the components and parts covered herein. No one is authorized to alter, modify, or enlarge this limited warranty, or its exclusions, limitations and reservations.

Corrections of defects and improper workmanship in the manner, and for the applicable time periods, provided for herein shall constitute fulfillment of all responsibilities of Farm King to the purchaser, and Farm King shall not be liable in negligence, contract, or on any other basis with respect to the subject equipment.

This limited warranty is subject to any existing conditions of supply which may directly affect Farm King's ability to obtain materials or manufacturer replacement parts.

Buhler Industries Inc. reserves the right to make improvements in design or changes in specifications to its products at anytime, without incurring any obligation to owners of units previously sold.



[www.farm-king.com](http://www.farm-king.com)

# Farm King

301 Mountain Street South  
Morden, MB R6M 1X7  
E-mail: [info@buhler.com](mailto:info@buhler.com)  
[www.farm-king.com](http://www.farm-king.com)

Equipment shown is subject to change without notice.  
©2022 Buhler Trading Inc. Printed in Canada TSX:BUI